

SOMMERKAMP[®]

CITIZENS BAND TRANSCEIVER INSTRUCTION MANUAL

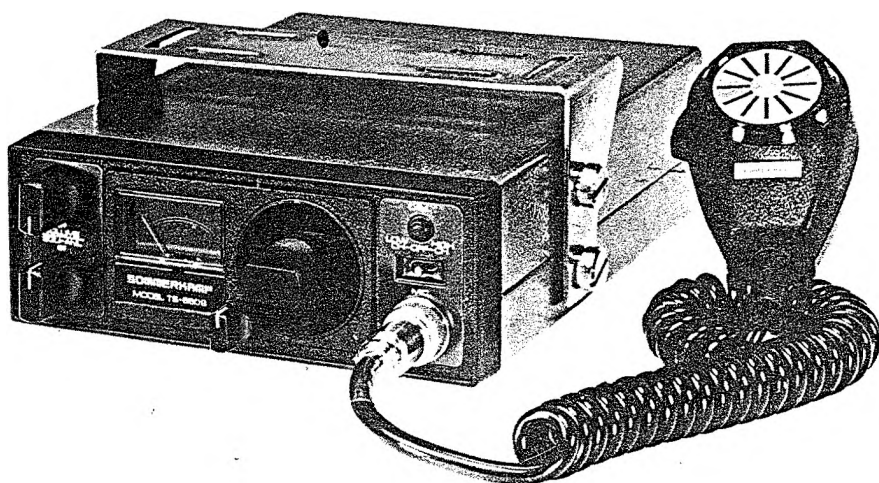

MODEL: TS-660S

SPECIFICATIONS for TS-660S

Semiconductors:	22 transistors, 9 diode, 2 S. C. R.
Transmitter System:	Synthesised crystal controlled Collector modulation AM.
Frequency:	60 channels on 27 MHz.
Output Power:	10 watts.
Band Width:	8 KHz (max).
Antenna Impedance:	50—52 ohms.
Receiver System:	Duble conversion superheterodyne, crystal controlled.
Sensitiuity:	1 μ V or better for 100mW output, 10 dB signal to noise ratio.
Intermediate Frequency:	455 KHz, 10.7 MHz.
Receiver Sensitivity:	25 dB down at 10 KHz.
Squelch Sensitivity:	2 μ V.
Audio Output Power:	3 watts in 10 % distortion.
Power Source:	11~16 volt D. C. Negative Ground.
Power Consumption:	TX-1.8A at no modulation. RX-0.3A at no signal.
Microphone:	Dynamic type with press-talk switch.
Speaker:	Dynamic type, V. Coil 8 ohm.
Size:	156×58×205 mm
Weight:	1.5 kg
Accessories:	Mounting bracket, Mounting hard ware, power cord.

SOMMERKAMP ELECTRONIC

CH-6816 BOX 130
LUGANO TELEX 79314

INSTALLATION

Mounting bracket and screws are supplied for mounting the transceiver underneath the dashboard. Microphone hanger and screws are also supplied.

For electrical connection, first make sure that the transceiver is turned off. Connect the red wire to the ACC terminal of the ignition switch or + terminal of battery and ground the black wire to the chassis of the vehicle. The black wire should be grounded as short as possible to minimize the noise interference.

This transceiver is designed for use with the negative ground system.

(For installation in the positive ground system, see the following instructions.)

Installation in positive ground system:

- a) Since the cabinet is commonly connected to all B minus potentials in the transceiver, the transceiver must be electrically isolated from the chassis of the vehicle at all times. (See Fig. 1 for connection with power source.)

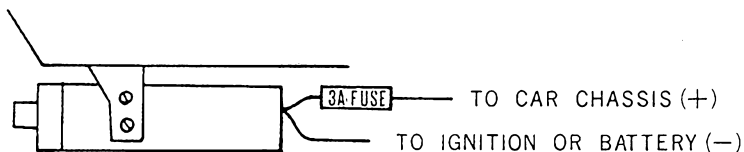

TRCV CHASSIS TO BE
INSULATED FROM CAR FIG. 1

- b) Obtain a pair of 0.01 mfd. @500V ceramic capacitors. Cut the antenna coaxial cable approximately 3 inches from the male connector. Connect one of the 0.01 capacitors in line with the center copper wire of the coaxial cable and solder. Tape the connections. Add the other capacitor in line with the shielding braids and solder. Tape the entire exposed braids and capacitor for insulation. These capacitors, in line with the conductors of the coaxial cable, now isolate the antenna ground from the ground of the transceiver. (See Fig. 2)

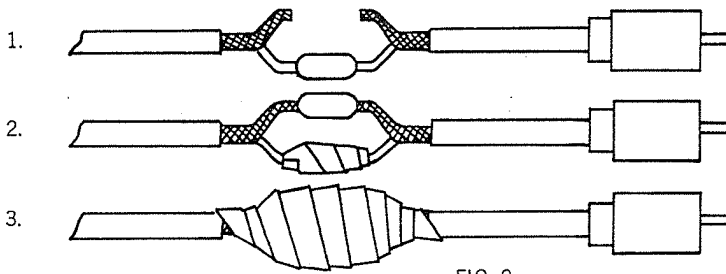

FIG. 2

c) The mounting bracket must be isolated from the chassis of the vehicle in such a manner as shown in Fig. 3.

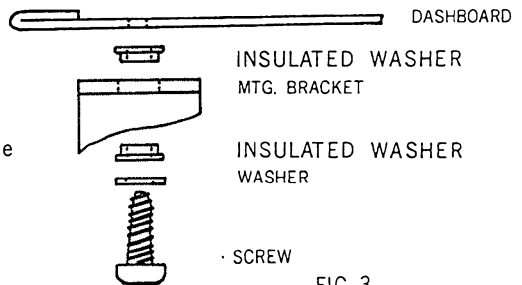

FIG. 3

ANTENNA

Antenna is one of the most important factors for the operation with maximum efficiency. A quarter wave antenna can be successfully mounted for mobile station. The antenna impedance should be 50 ohms. For the details, consult with your distributor.

Important:

Do not operate the transceiver without a proper antenna or dummy load connected to the antenna connector, as the transmitter transistors may be damaged.

OPERATING INSTRUCTIONS

The transceiver is ready to operate when it is installed with an antenna properly connected. Note that the communication range differs depending upon the environment where the transceiver is operated. You may reach 30 or 40 kilometers where no obstacle exists, but the range may be limited to 5 or 6 kilometers in cities where many high buildings disturb the communication.

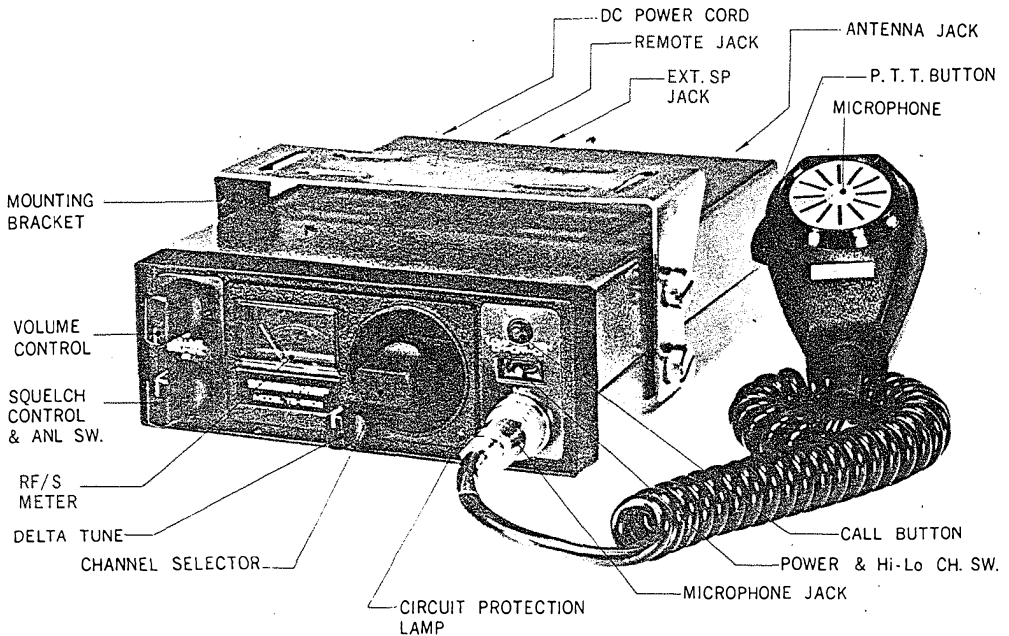

- 1) Turn the set on by switching the LOW-OFF-HI snap switch to the desired channel range and the channel dial will be lighted. Turn the volume control clockwise to increase the audio sound. Note that the volume control knob is only for adjusting the audio volume, not to increase the transmitting power.
- 2) Set the DELTA-TUNE for best reception.
- 3) Turn the squelch control clockwise until incoming noise is eliminated. Do not turn it excessively as the sensitivity may be reduced.
- 4) Turn the squelch control counter-clockwise to switch off the ANL (Automatic Noise Limiter).
- 5) Turn the channel selector knob to the desired channel.
- 6) For transmitting, press the button on the microphone and speak into it normally. Release the button for receiving.

METER

The meter reading indicates the signal strength at receiving, and functions as an output indicator at transmitting, and the meter pointer should be within the Red zone under the normal conditions.

CIRCUIT PROTECTION INDICATOR LAMP

The Lamp is on when the antenna is mismatched, and the transmitting circuit will be cut off.

TONE-LIGHT CALLING DEVICE

The Model TS-660S is equipped with a selective tone-light calling device which works on a 1,750 Hz signal. To call the other station, push the push-to-talk button and the call button simultaneously, when the calling signal is transmitted. When the signal is received, a peep tone is produced and the call-light lamp will be lighted at the other station, and the lamp stays on until the other station answers.

Please note that the device works only when the other station is switched on and that the buttons on the calling side must be depressed at least for 10 seconds.

List of accessories:

Mounting bracket	1
Hexagonal screw	4
Microphone hanger	1
Screw for above	2

List of channel frequencies:

CHANNEL NO.	LOW CH. FRQ.	HIGH CH. FRQ.	CHANNEL NO.	LOW CH. FRQ.	HIGH CH. FRQ.
1	26.965MHZ	27.305MHZ	15	27.135MHZ	27.455MHZ
2	26.975MHZ	27.315MHZ	16	27.155MHZ	27.465MHZ
3	26.985MHZ	27.325MHZ	17	27.165MHZ	27.475MHZ
A	26.995MHZ	27.335MHZ	18	27.175MHZ	27.485MHZ
4	27.005MHZ	27.345MHZ	19	27.185MHZ	27.495MHZ
5	27.015MHZ	27.355MHZ	20	27.205MHZ	27.505MHZ
6	27.025MHZ	27.365MHZ	21	27.215MHZ	27.515MHZ
7	27.035MHZ	27.375MHZ	22	27.225MHZ	27.525MHZ
8	27.055MHZ	27.385MHZ	B	27.235MHZ	27.535MHZ
9	27.065MHZ	27.395MHZ	C	27.245MHZ	27.545MHZ
10	27.075MHZ	27.405MHZ	23	27.255MHZ	27.555MHZ
11	27.085MHZ	27.415MHZ	D	27.265MHZ	27.565MHZ
12	27.105MHZ	27.425MHZ	24	27.275MHZ	27.575MHZ
13	27.115MHZ	27.435MHZ	E	27.285MHZ	27.585MHZ
14	27.125MHZ	27.445MHZ	F	27.295MHZ	27.595MHZ

SCHEMATIC DIAGRAM

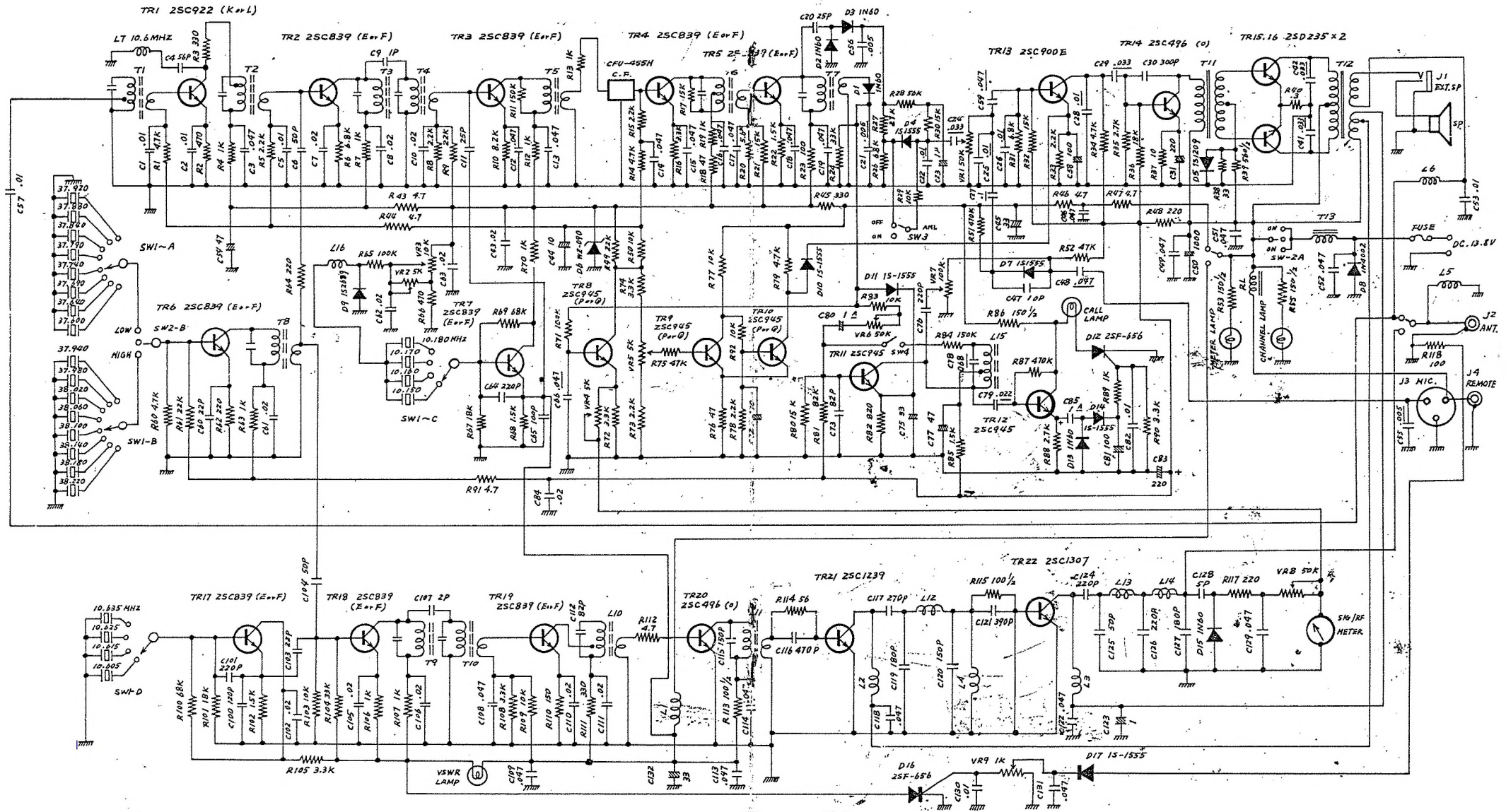

COMPLETE PARTS LAYOUT

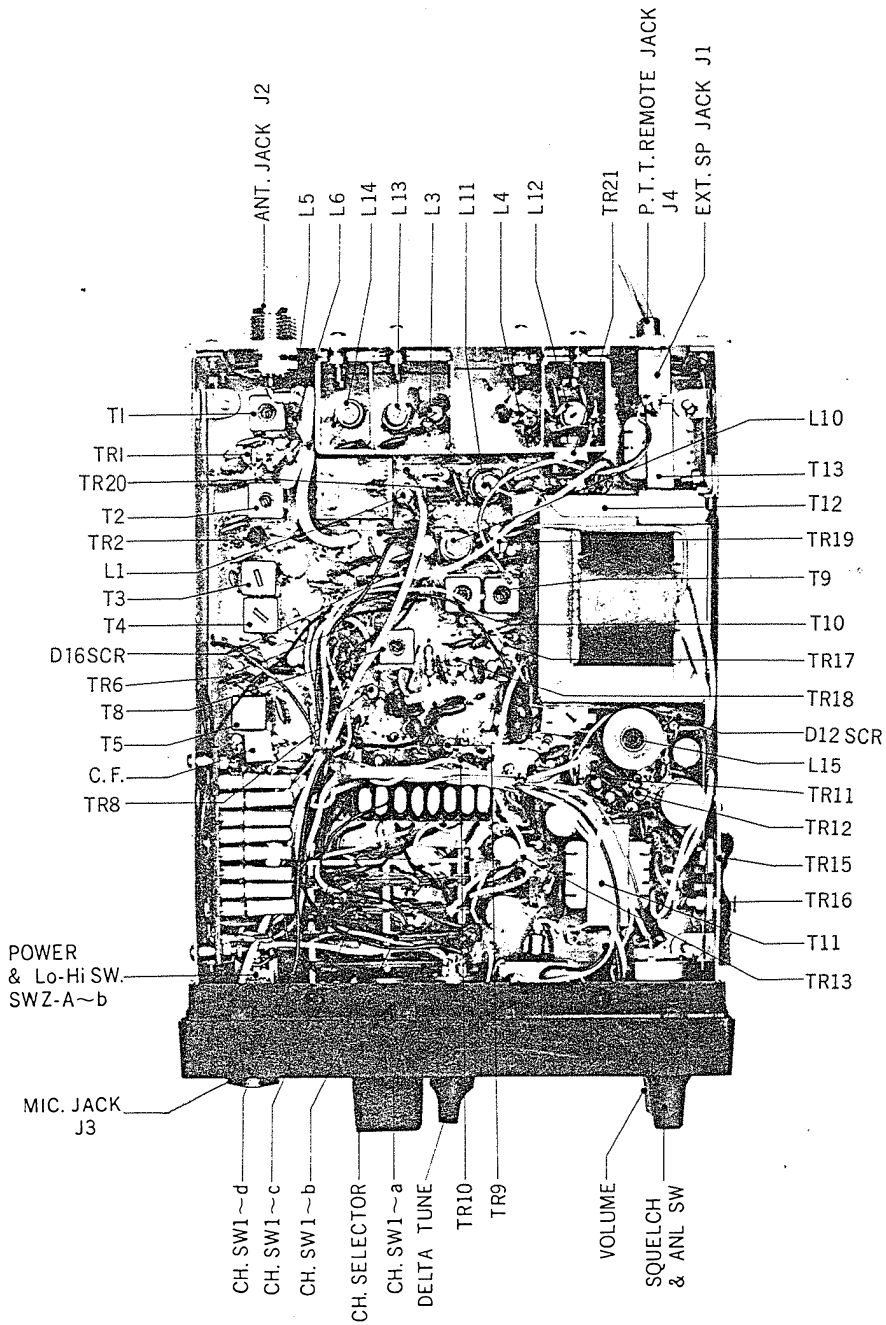

PRINTED CIRCUIT BOARD PARTS LAYOUT

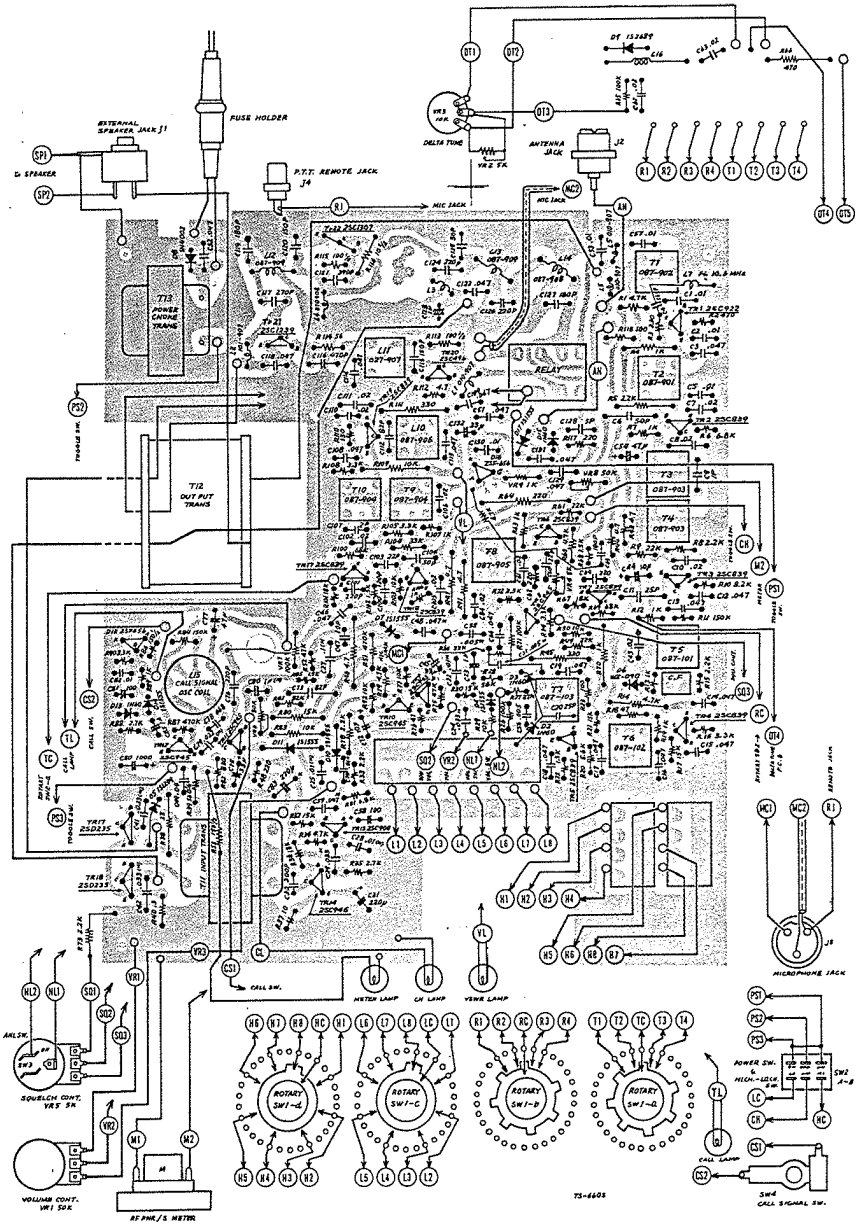

PARTS LIST for TS-660S

DESIGNATION	PARTS NAME	PARTS NO.
MP-301	Front Frame	483014-660
MP-302	Chassis Frame	482009-660
MP-203	Back Panel	484100
MP-105	Cabinet Cover (Upper)	483016
MP-106	Cabinet Cover (Lower)	483015
MP-107	Mounhing Bracket	484085
MP-303	Front plate (L)	494187-L
MP-304	Front plate (R)	494187-R
MP-305	Brand plate	494184
MP-306	Back plate	494190
MP-110	Mounting Bracket for Meter	484064
MP-208	Mounting Bracket for Output Transformer	484080
MP-209	Heatsink for 2SC1307 (A)	484102
MP-210	Heatsink for 2SC1307 (B)	484101
MP-211	Meter Lamp Reflection plate	484063
MP-212	Channel Indicator Screen	484107
MP-213	Screen Holder	484106
MP-214	Mounting Bracket for channel Lamp	484108
MP-111	Call Switch Contact	484086
MP-112	Call switch Spring	484087
MP-117	Knob for channel Selector	484116
MP-17	Knob for Vol./Squ. Control	474011
MP-307	Knob for Delta tune Control	494199
MP-118	Nut for Channel Selector	484073
MP-120	Screw for Mounting Bracket	484098
MP-308	Channel Indicator plate	484115
MP-309	Heat sink for 2SD235	494179
MP-310	IS1209 Holder	484118
J1	EXT. SP. Jack	SJ-296
J2	Antenna Jack	MRM/INCH
J3	Microphone Jack	MC-01
J4	Remote Jack	RCA-1P
EP201	Power Cord with Contact & Fuse holder	W-002
F1	Fuse 3A	F-3A
M	Meter	D33B35R
SP	Speaker	87P-30-1
PL1	Pilot Lamp 9V-30mA	PL-9-30
PL2	Pilot Lamp 12V-50mA	PL-12-50
SW1	Channel Selector Rotary switch	43-30B
SW2	Toggle switch	TG-3P
MIC	Microphone Complete	22-256-13
EP-202	Crystal Socket 8P	XS-8P
EP-203	Crystal Socket 4P	XS-4P
EP-301	Crystal Socket 1P	XS-1P
RL	Relay	SR-74
TR1	Transistor	2SC922
TR2 3,4,5,6,7,17,18,19	Transistor	2SC839

PARTS LIST for TS-660S

DESIGNATION	PARTS NAME	PARTS NO.
TS8,9,10,11,12	Transistor	2SC945
TR13	Transistor	2SC900
TR14, 20	Transistor	2SC496
TR21	Transistor	2SC1237
TR22	Transistor	2SC1307
TR15, 16	Transistor	2SD235
D1,2,3,13,15	Germanium Diode	1N60
D4,5,7,10,11,17	Slicon Diode	1S 1555
D6	Zener Diode	WZ-090
D8	Slicon Diode	1N4002
D12, 16	S. C. R	2SF656
D5	Varistor	1S-1209
D9	Varicap Diode	1S-2689
T1	RF Coil (Black) 087-902	T-2001
T2	RF Coil (White) 087-901	T-2002
T3	I. F. T. 10.7 MHZ (orange) 087-903	T-2003
T4	I. F. T. 10.7MHZ (Orange) 087-903	T-2004
T5	I. F. T. 455KHZ (Yellow) 087-101	T-2005
T6	I. F. T. 455 KHZ (White) 087-102	T-2006
T7	I. F. T. 455 KHZ (Black) 087-103	T-2007
T8	O. S. C. Coil 37 MHZ (Red) 087-905	T-2008
T9	TX Tuning Coil (Green) 087-904	T-2009
T10	TX Tuning Coil (Green) 087-904	T-2010
T11	Input Transformer	EI-2901
T12	Output Transformer	EI-5701
T13	Power Choke Transformer	EI-2401
L1,2,3,4,5,6	RF Choke Coil	L-1033
L7	Filter Coil 10.6MHZ	L-2016
L16	Delta tune Choke Coil	L-2017
L10	RF Coil 087-906	L-2011
L11	RF Coil 027-907	L-2012
L12	RF Coil 087-909	L-2013
L13	RF Coil 087-909	L-2014
L14	RF Coil 087-908	L-2015
L15	Call Signal O. S. C. Coil	L-2010
MF	Ceramic Filter	CFU-455H
EP-204	P. C. Board	6302
EP-302	Sub P. C. Board	DT660
VR1	Variable Resistor (Volume) 50K ohm	VR1650K
VR2, 4	Semi Variable Resistor 5K ohm	SVR005K
VR3	Variable Resistor (Deltatune) 10K ohm	VR1310K
VR5	Variable Resistor (Squelch) 5K ohm	VR165KS
VR6, 8	Semi Variable Resistor 50K ohm	SVR050K
VR7	Semi Variable Resistor 100K ohm	SVR100K
VR9	Semi Variable Resistor 1K ohm	SVR001K