

SOMMERKAMP[®]

CITIZENS BAND
TRANSCEIVER

5 WATT 80 CHANNEL
P. L. L-SYNTHESIZED

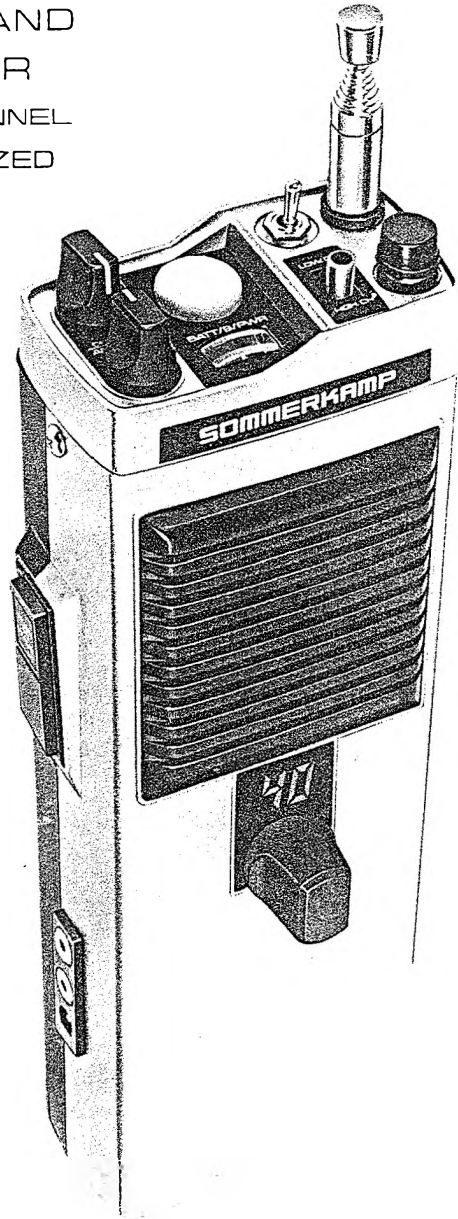

MODEL
TS-5680

INSTRUCTION MANUAL

CONTROL LOCATIONS:

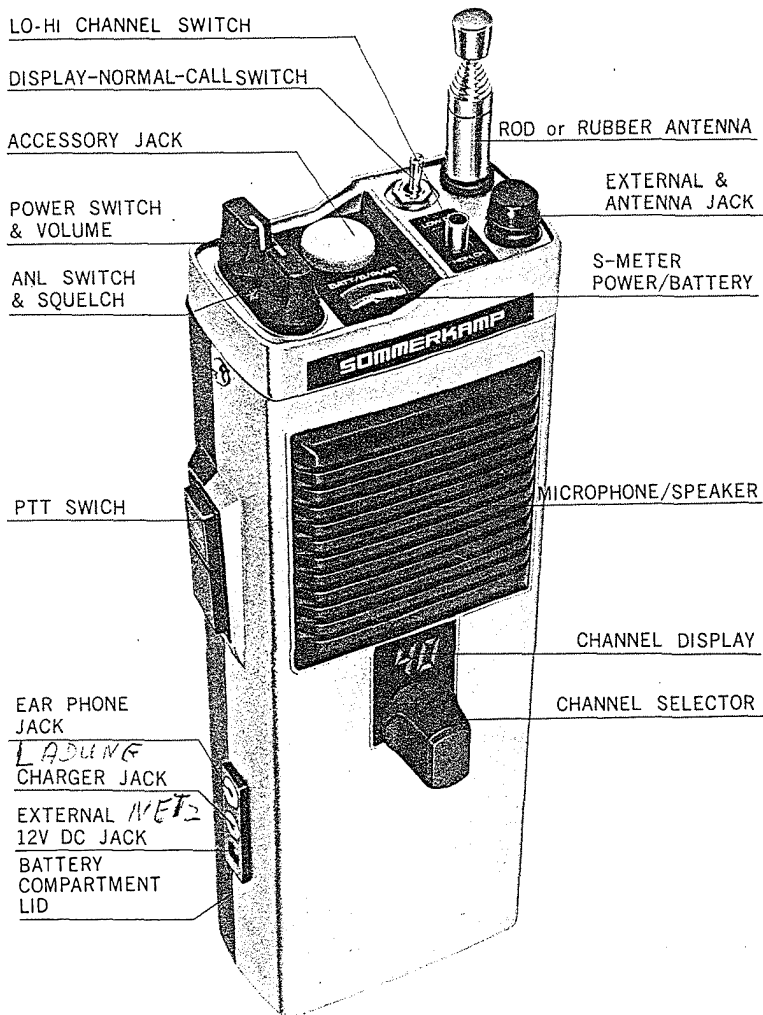

PACKING LIST:

Beside this manual, the carton shall contain the following items:

- 1 Transceiver TS-5680
- 1 Carrying case with shoulder strap
- 1 Earphone case with earphone
- 2 pcs dummy batteries inside the batterie case
- 1 shortening plug in the accessory jack

GENERAL DESCRIPTION

Your SOMMERKAMP TS-5680 transceiver has been designed for continuous heavy duty portable application. It can be operated with external antenna, power supply, headset, telephoneset incorporating automatic voice operated transmit/receive switching, short type rubber antenna, external selective calling with automatic answerback and many more.

GENERAL :

The transceiver is designed to operate with internal dry cells or rechargeable nickel-cadmium batteries such as N500AA set with the 12360 charger, or with an external 12V DC power supply such as NT30, or with an automobile battery. To prevent excessive battery drain, this transceiver has a stand-by switch in combination with the operate and call switch, which by a timing circuit and a switching transistor switches the receiver on for 2 seconds and off for 10 seconds. This device extends the battery life 6 times longer compared with continuous squelched stand-by operation. It is necessary, however, for a calling station to call by minimum 10-15 seconds before reception and contact is possible.

RECEIVER SECTION:

The receiver section is designed to receive amplitude modulated signals (AM/A3) in the 26.965 to 27.855 MHz. (11 meter) citizens band. The unique combination of low noise Field Effect Transistors (FET), double conversion, a combination of mechanical ceramic, and L/C filters, fully automatic noise limiter and a hifi quality speaker amplifier will give you exceptional reception quality in this fine piece of equipment.

In addition, the above combination of the latest technology provides you with a sensitivity and unwanted signal rejection and noise suppression available previously only in space and military communication equipment.

The power supply of the receiver section is stabilized by an extreme sharp cut-off Zener diode controlled series stabilizer to obtain the high sensitivity and unwanted signal rejection. The fully automatic series gate noise limiter, which virtually cuts off the audio output during ignition noise pulses, is defeatable to make even the weakest signal audible which otherwise would be cut off by the threshold level of the ANL switching diode.

The high squelch sensitivity is achieved by using a separate squelch detector and switching circuit with a carefully balanced hysteresis. The transformerless hifi quality audio power amplifier will drive any load between 32 ohms and indefinite such as internal speaker/microphone combination or external speaker/microphone or headset combinations having the above impedances.

The meter indicates the field strength during reception of a signal, and without signal the battery condition.

TRANSMITTER & MODULATOR SECTION:

The transmitter section is designed for continuous heavy duty transmission of amplitude modulated (AM/A3) signals in the 26.965 to 27.855 MHz. (11 meter) citizens band.

The transmitter consists of a Phase Locked Loop circuit and one-crystal controlled oscillator, of which output is synthesized in a class B mixer, followed by a double tuned filter, class AB1 buffers, and a highly efficient collector-modulated class C driver and power output stage, coupled by series and pi-matching filters to the antenna jack and via a loading coil to the rod antenna.

The modulator consists of an input audio filter, integrated pre-and power amplifier and modulation transformer. This gives you the lowest possible modulation distortion and up to 100% modulation. The input is designed for 1 to 10K ohm dynamic microphone or 32 ohm speaker/microphone combination with a 1K ohm resistor in series.

RECEIVE/TRANSMIT SWITCHING:

The receive/transmit switching is done by a single pole, single throw micro switch with a life time of about 5 million operations and a combination of NPN and PNP switching transistors which also function in the receive mode as series voltage stabilizer. For remote switching, a parallel contact is provided at the accessory jack.

METER:

The combination meter provides you with the following functions:

During receive mode.....it indicates the incoming signal strength, and without incoming signals the battery condition.

During transmit mode... it indicates the output power.

CHANNEL DISPLAY

The channel in operation can be read on the digital channel readout display above the channel selecting knob.

When the Display-Normal-Call switch is center switched, the digital channel readout will indicate the number for a few second in order to save battery consumption. However, when the Display-Normal-Call switch frontward switched, the channel readout will stay always indicating the channel number in operation. This position will mainly be used for checking the channel number in use.

POWER SUPPLY:

This transceiver is designed to operate with a nominal 12V DC power supply such as the internal dry cells or nickel-cadmium rechargeable batteries or an external power supply delivering at least 1.5 amperes. The equipment will operate from 10-16V DC without any damage.

UNPACKING AND CHECKOUT

Unpack the carton carefully and check for exterior damages.

Check that the volume control is in the OFF position, the squelch control in the ANL-OFF position and the Display-Normal-Call switch in center position.

Press the dent of the battery compartment lid and pull it out toward the bottom.

Lift out the battery holder and insert 8 dry cells into the holder as indicated, \oplus to \oplus , \ominus to \ominus pole. Leave the 2 dummy batteries in the holder as they are. If you use rechargeable batteries, insert 10 pieces of them in the same manner as above but remove the dummy batteries.

Snap the battery holder onto the snap connector provided and reinsert the holder into the compartment.

Replace the compartment lid by inserting it straight from the bottom up until it snaps in rightly.

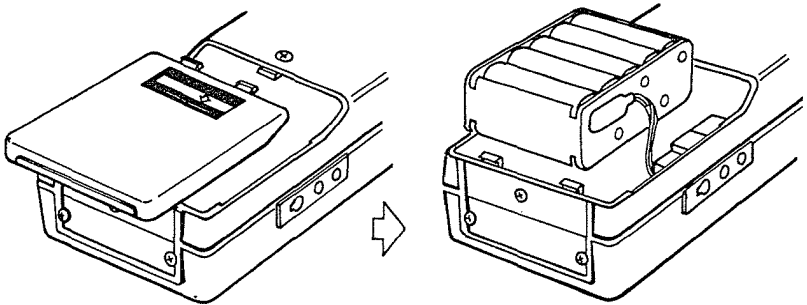

Then switch the transceiver ON by rotating the volume control clockwise and check that the meter needle moves into the red field. If the meter needle does not move, switch OFF immediately and check if the Display-Normal-Call switch is in the center position. If this is the case, open the battery compartment to remove the battery holder to ensure that the batteries are correctly inserted.

Now turn the volume control until noise is heard from the speaker. Then extend the rod antenna to the full length.

Rotate the channel selector step by step CH1 to CH40 both for LO & HI CH. and check that some noise and/or signal is heard on each channel.

Push the push-to-talk (PTT) switch and observe the meter needle. It shall move into the red field. Now whistle into the speaker/microphone. The needle shall move a little. The same applies while pressing and releasing the call switch between operate and call.

Repeat this check on each channel from 1 to 40. This completes the checkout.

OPERATION

Extend the rod antenna competely and switch the transceiver ON by rotating the volume control clockwise.

Rotate the channel switch to the desired channel.

Adjust the volume control to a comfortable level.

Press the PTTswitch and talk with a normal voice into the speaker/microphone from a distance of 5-10 cm. After completing your transmission, release the PTT switch, and the transceiver is ready for reception. Always remember that your opposite party cannot hear you while he is transmitting.

Adjust the squelch control so that the background noise just disappears during non-transmitting periods of your opposite party.

To answer the received call, push the PTT switch and talk into the speaker/microphone.

To receive weak signals, turn the squelch control fully counter-clockwise so that the ANL is switched OFF.

To switch the transceiver OFF, turn the volume control fully counter-clockwise until a click is heard and the meter needle moves into the black field.

Important:

If you will not operate the transceiver for a long time, remove the batteries from the equipment so that they will not corrode and damage the transceiver. The same applies if you use the transceiver continously with an external power supply.

ACCESSORIES

To install N500AA rechargeable nickel-cadmium batteries, follow the instructions under the Chapter UNPACKING AND CHECKOUT of this manual.

Charge the N500AA nickel-cadmium batteries by plugging the 1236 charger into the charger jack. Charge for 14 hours. It is not possible to operate the transceiver during charging.

To use the transceiver with the NT30AC power supply, plug it into the external power jack. For using a different power supply, it is recommended to select a low ripple, stabilized supply, delivering at least 1 ampere at 12V with a maximum output voltage of 16V.

To connect the transceiver to a 12V automobile battery, use an 1 ampere fuse in series with the positive wire.

Solder the positive wire to the center of the external power plug and the negative wire to its fin.

In case you use the transceiver with the RA1608 rubber antenna, screw out the telescopic antenna and replace it with the rubber antenna.

For private listening, plug the earphone into the earphone jack. The internal speaker will be disconnected.

To operate the transceiver with a 50 ohm external antenna, plug the coaxial connector into the external antenna jack and remove, if installed, the RA1608 rubber antenna.

MICROPHONE JACK

The 7-pin DIN standard accessory jack has the following internal connections:

- | | |
|-------------------------------------|---|
| 1. Internal speaker | 5. Internal microphone input (Z 1K ohm) |
| 2. AF.out for selective call. | 6. +12V for VOX unit etc. |
| 3. Audio output (Z 8 ohm-10K ohm) | 7. Transmit/Receive switching. |
| 4. Microphone input (Z 600-10K ohm) | Case = ground |

Always operate the transceiver with the microphone plug inserted in the microphone jack, or with the following external connections:

1. Microphone with VOX

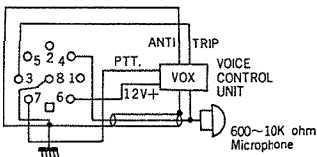

5. External microphone/speaker with PTT.

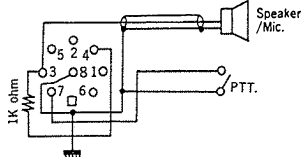

2. Headset or Telephoneset with PTT.

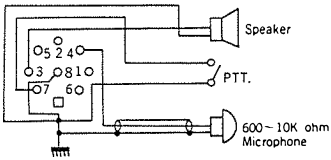

3. External microphone

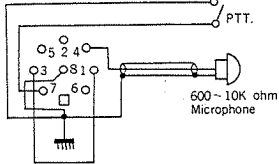

4. Headset or Telephoneset with VOX

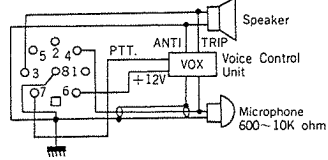

5. Internal connection

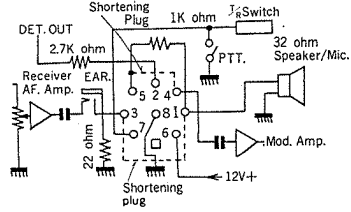

7. Parrot 76

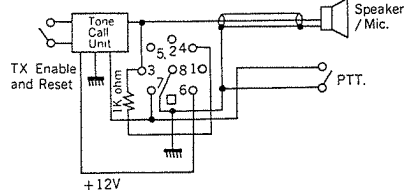

LIST OF CHANNEL FREQUENCY

CH.	LOW.CH. (MHz)	HIGH.CH. (MHz)	CH.	LOW.CH. (MHz)	HIGH.CH. (MHz)
1	26. 965	27. 415	21	27. 215	27. 665
2	26. 975	27. 425	22	27. 225	27. 675
3	26. 985	27. 435	23	27. 255	27. 705
4	27. 005	27. 455	24	27. 235	27. 685
5	27. 015	27. 465	25	27. 245	27. 695
6	27. 025	27. 475	26	27. 265	27. 715
7	27. 035	27. 485	27	27. 275	27. 725
8	27. 055	27. 505	28	27. 285	27. 735
9	27. 065	27. 515	29	27. 295	27. 745
10	27. 075	27. 525	30	27. 305	27. 755
11	27. 085	27. 535	31	27. 315	27. 765
12	27. 105	27. 555	32	27. 325	27. 775
13	27. 115	27. 565	33	27. 335	27. 785
14	27. 125	27. 575	34	27. 345	27. 795
15	27. 135	27. 585	35	27. 355	27. 805
16	27. 155	27. 605	36	27. 365	27. 815
17	27. 165	27. 615	37	27. 375	27. 825
18	27. 175	27. 625	38	27. 385	27. 835
19	27. 185	27. 635	39	27. 395	27. 845
20	27. 205	27. 655	40	27. 405	27. 855

BLOCK DIAGRAM

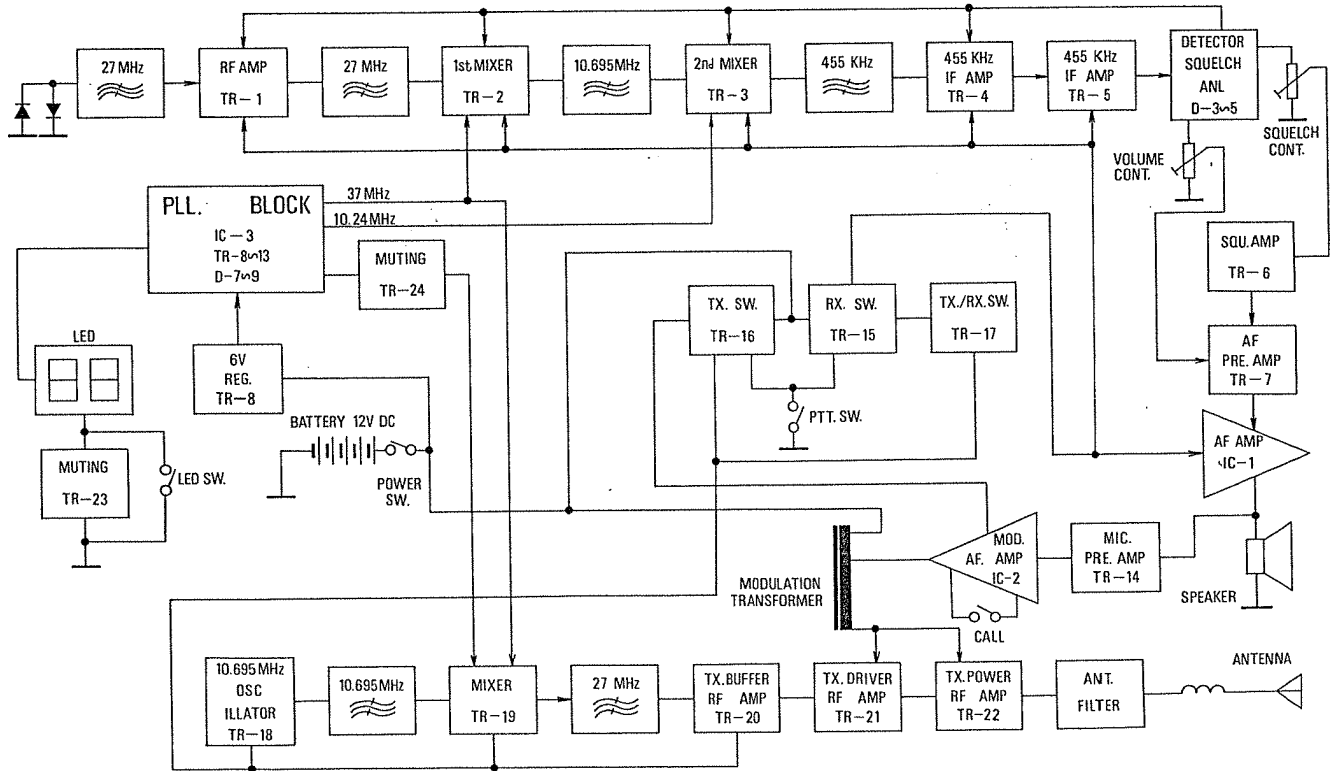

CIRCUIT DIAGRAM

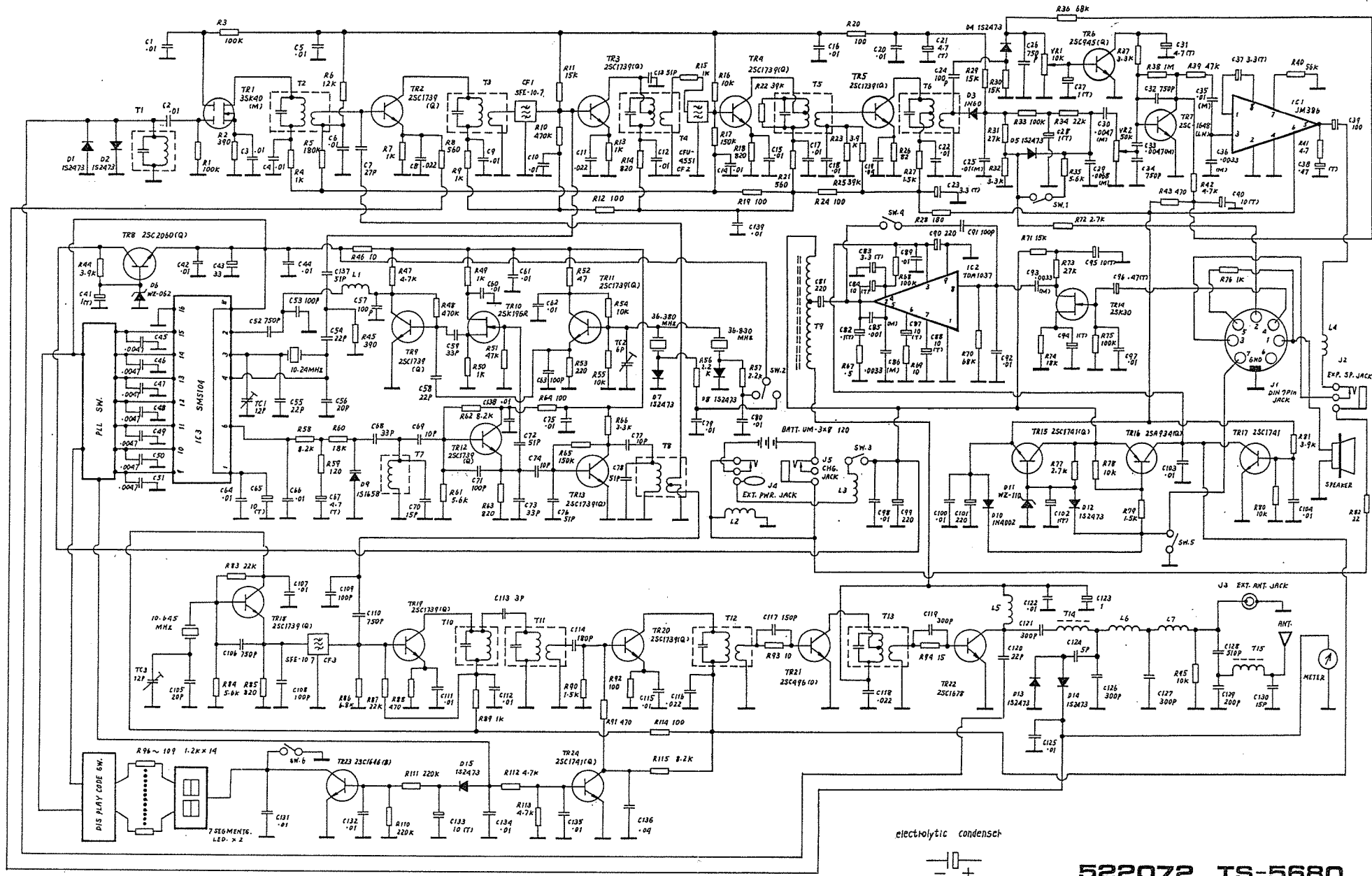

electrolytic condensch



PRINTED CIRCUIT BOARD PARTS LAYOUT

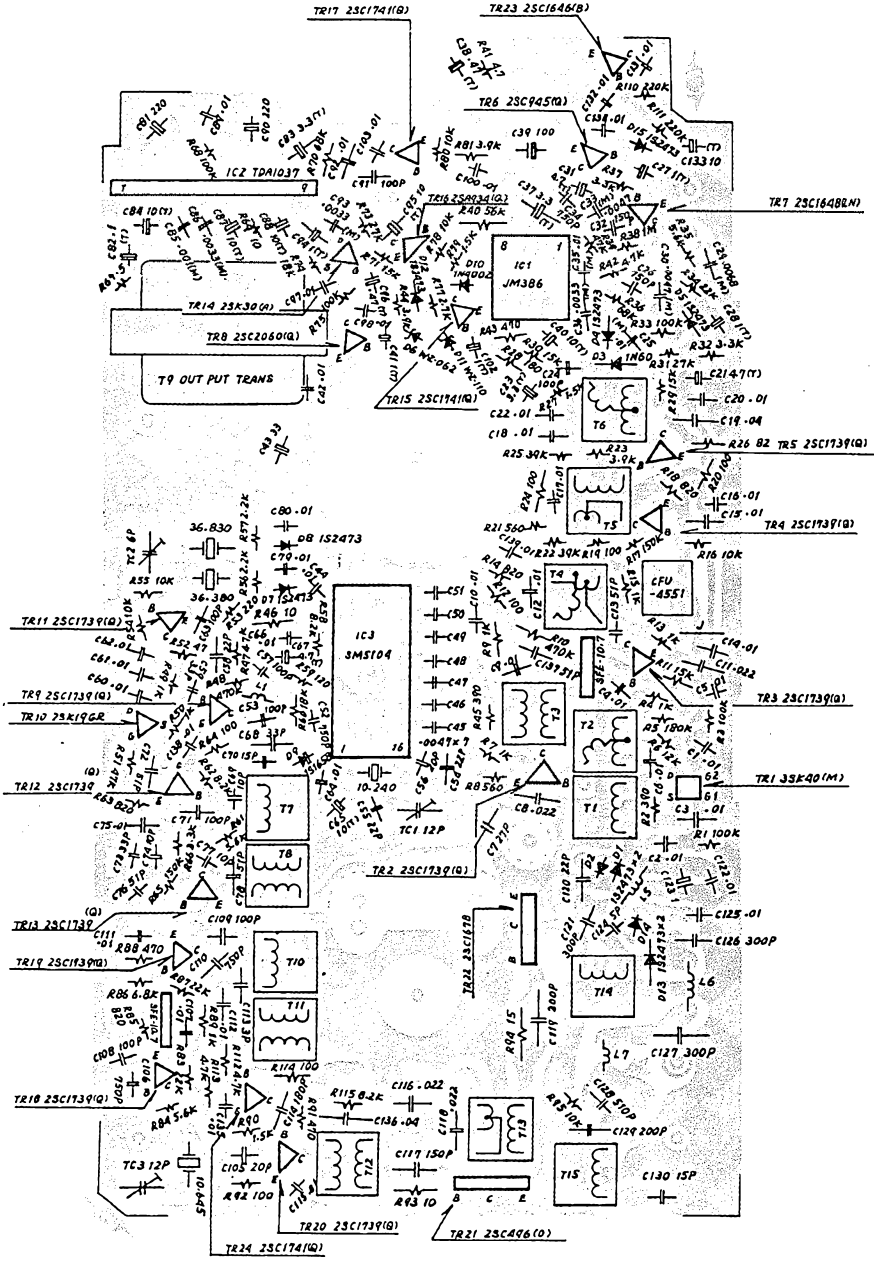

WIRING LAYOUT UPPER VIEW

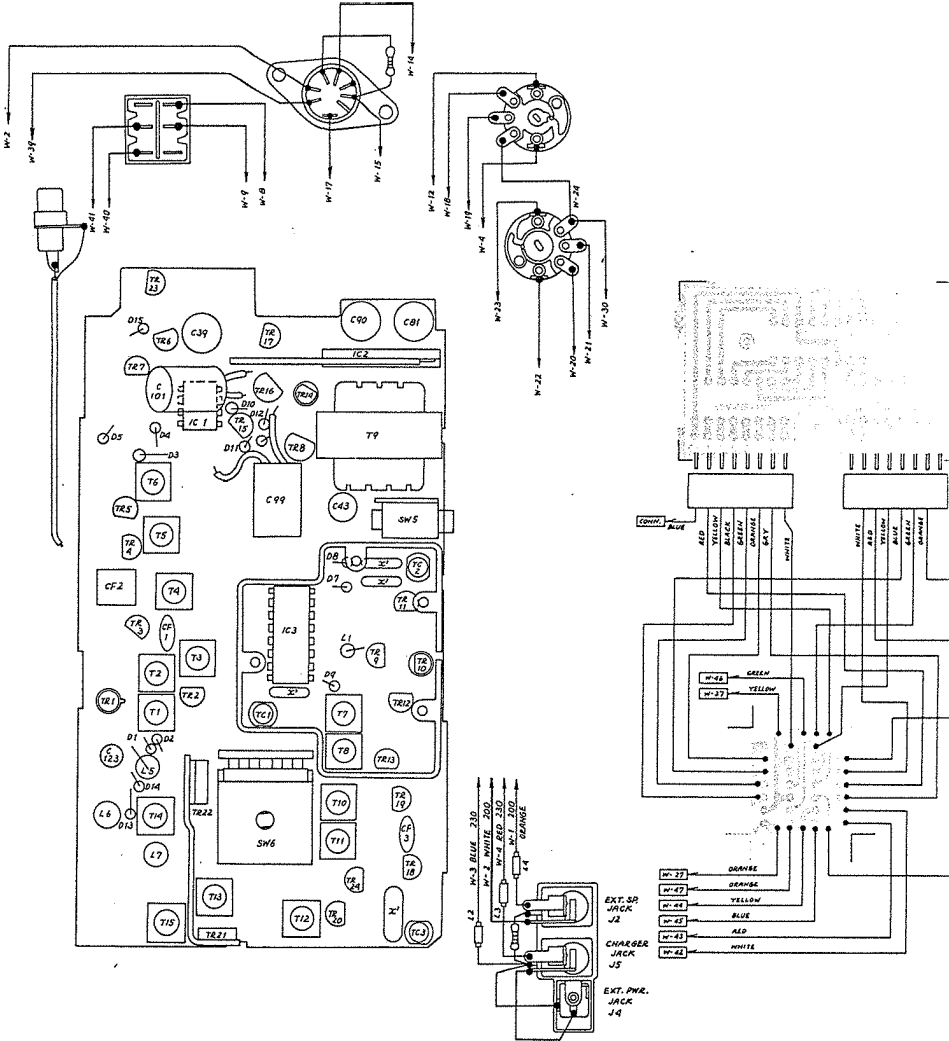

WIRING LAYOUT BOTTOM VIEW

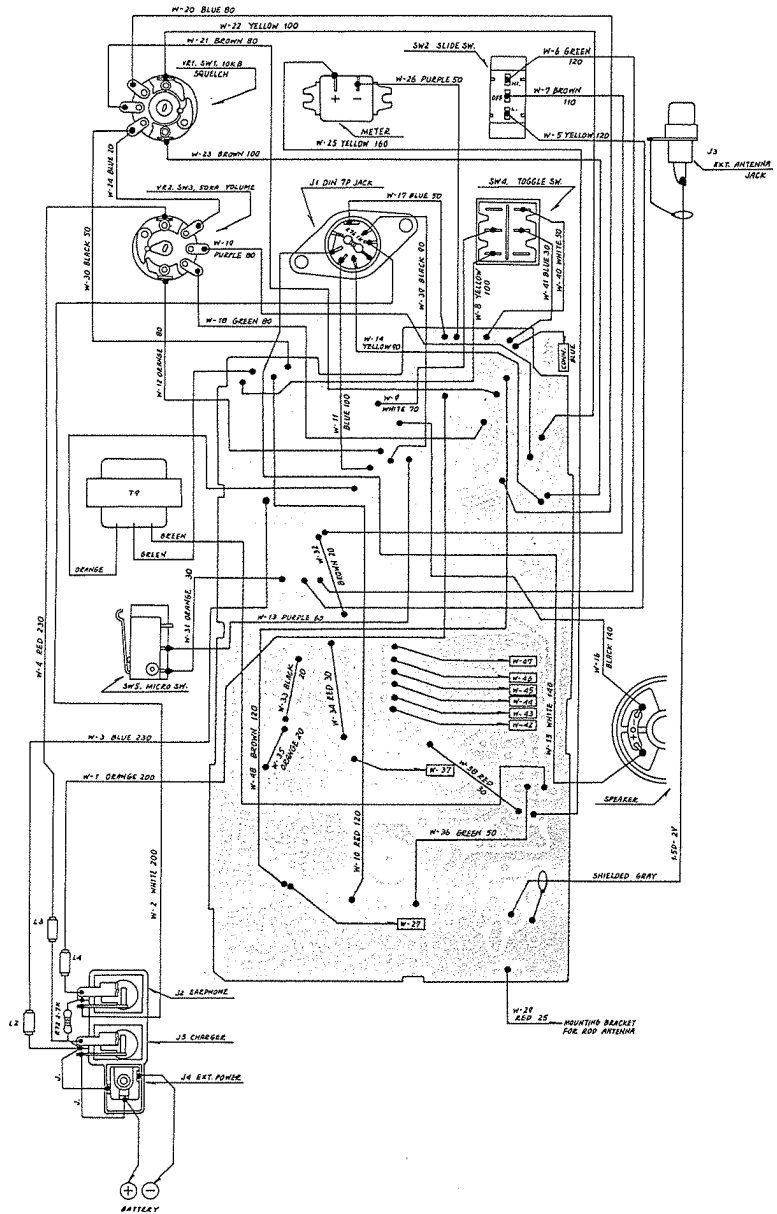

PARTS LIST for TS-5680

DESIGNATION	PARTS NAME	PARTS NO.
IC1	Integrated Circuit	JM386
IC2	Integrated Circuit	TDA1037
IC3	Integrated Circuit	SM5104
CF1, 3	Ceramic Filter	SFE-10.7MS-2
CF2	Ceramic Filter	CFU-455-1
TR10	FET	2SK19-GR
TR14	FET	2SK30-A
TR1	FET	3SK40-M
TR21	Transistor	2SC496-O
TR16	Transistor	2SA934-Q
TR6	Transistor	2SC945-Q
TR23	Transistor	2SC1646-B
TR7	Transistor	2SC1648-LN
TR22	Transistor	2SC1678
TR ^{2, 3, 4, 5, 9, 11} _{12, 13, 18, 19, 20}	Transistor	2SC1739-Q
TR15, 17, 24	Transistor	2SC1741-Q
TR8	Transistor	2SC2060-Q
D ^{1, 2, 4, 5, 7, 8} _{12, 13, 14, 15}	Silicon Diode	1S2473
D10	Silicon Diode	1N4002
D9	Varicap Diode	1S1658
D3	Germanium Diode	1N60
D6	Zener Diode	WZ-062
D11	Zener Diode	WZ-110
VR2, SW3	Variable Resistor (Volume) 50K ohm	13-50KAS
VR1, SW1	Variable Resistor (Squelch) 10K ohm	13-10KBS
SW2	Slide Switch	SLS-C124-MR
SW4	Toggle Switch	8A-2051
SW5	Micro Switch (P.T.T.)	SS-5
SW6	Rotary Switch	SRS303U112
JIS	DIN Type 7pin Socket	CS-279
JIP	Shortening Circuit Plug for DIN Socket	CP-123
J2, 4, 5	Tri Jack	C-G0112-01
J3	External Antenna Jack	RCA1P

PARTS LIST for TS-5680

DESIGNATION	PARTS NAME	PARTS NO.
T9	Output Transformer	T-5632
T10, 11, 12	TX Mixer & Buffer Tuning Coil	5KCW-0345
L5, 7	TX Final Choke, π Matching Coil	005-901
L4	EXT. SP. Choke Coil	005-903
T1	RX RF Tuning Coil	011-901
T13	TX Driver Tuning Coil	011-902
T3	IFT 10.7MHz	011-904
T5	IFT 455KHz	011-906
L6	TX π Matching Coil	011-917
T7	PLL VCO Coil	231-001
T8	VCO Amp Coil	313-001
T2	RX RF Tuning Coil	313-002
T6	IFT 455KHz	313-101
T4	IFT 455KHz	313-102
L2, 3	Power Choke Coil	313-601
L1	PLL Mix Filter Coil	313-602
T15	ANT. Loading Coil	313-801
T14	TX Final Tuning Coil	313-802
M	Meter	21A002
ANT	Rod Antenna	A-32
LED	LED Display	GL-6P202
K-A	Connector 8 pin	534490
K-B	Connector 8 pin	534491
TC2	Trimmer Condenser	CV05-A060
TC1, 3	Trimmer Condenser	CV05-C120
X'1	Crystal Oscillator Unit	10.240
X'2	Crystal Oscillator Unit	10.695
X'3	Crystal Oscillator Unit	36.380
X'4	Crystal Oscillator Unit	36.830
SP	Speaker 57mm 32 ohm IMP	57P-15-7
	Carrying Case	CC-5680DX
	Instruction Manual	IM-5680DX
	Gift Box	GB-5680DX

PARTS LIST for TS-5680

DESIGNATION	PARTS NAME	PARTS NO.
MP-507	Cabinet Front	522066
MP-508	Cabinet Top	523064
MP-5603	Cabinet Back	492021
MP-5604	Cabinet Cover for Batt.	493039
MP-5605	Speaker Grill	493038
MP-5609	Cabinet Bottom Plate	494198
MP-5608	P. T. T. Button Assembly	494200
MP-5606	Bushing for Rod Antenna	494205
MP-5611	Cap for EXT. ANT. Jack	494204
MP-5607	Knob for VOL/SQU Control	494199
MP-5626	Knob for Channel Selector	494231
MP-5610	Mounting Bracket for Rod Antenna	494202
MP-509	Frame for P. C. B.	524453
MP-510	Supporter for P. C. B.	524454
MP-511	Heatsink for TDA1037	514349
MP-512	Heatsink for 2SC1678	524449
MP-513	Shield for PLL.	524450
MP-514	Shield for PLL Cover	524451
MP-209	Mounting Bracket for Speaker	474008
MP-5614	Mounting Bracket for Microswitch	494216
MP-5624	Rod Antenna Cover	494219
	Battery Case Holder	494194
MP-515	Channel Indicator Screen	534486
MP-118	Nut for Channel Selector	484073
MP-516	Insulated Cover	534487
MP-5624	Speaker Net	494229
MP-5615	Brand Plate	494212
MP-517	Back Plate	534489
MP-5620	DIN Jack Plate	494209
MP-5617	VOL/SQU Plate	494225
MP-5616	P. T. T. Button Plate	494222
MP-518	Channel Plate	534488

SPECIFICATIONS

GENERAL:

Dimensions	230 (h) x 78 (w) x 43.5 (d) mm
Weight	850 grams without batteries
Power supply	8 penlight dry cells (12 volts) or 10 penlight rechargeable nickel-cadmium batteries (12.5 volts) or 12 volt external DC supply.
Cabinet	Aluminium die cast front and high impact ABS back
Channels	80 channels PLL SYNTHESIZED
Controls	volume; squelch; ANL; operate; call; channel
Microphone	internal microphone speaker combination
Semiconductors	3 integrated circuits; 22 transistors; 2 FET; 15 diodes
Special Features	Electronic T R switching; 40 X 2 channels automatic noise limiter; S, power and battery meter; exchangeable antenna; full accessory connector for remote operation.

RECEIVER:

Frequency range	26.965 to 27.855 MHz in 10 KHz steps
Sensitivity	0.5 μ V for 10dB S - N/N and 100 mW output at 30% 1KHz modulation
Selectivity	6KHz at -6 dB
Adjacent channel rej	better than 50 dB average
Audio output at 10%	250 mW
Spurious response	more than 50 dB down
Intermodulation	more than 50 dB down
Crossmodulation	more than 50 dB down
Squelch sensitivity	less than 0.1 μ V
Noise limiter	automatic series gate

TRANSMITTER:

Frequency range	26.965 to 27.855 MHz in 10 KHz steps
Input power	5 Watt
Modulation capability	100%
Modulation distortion	less than 5% at 95% modulation
Frequency tolerance	1.200 Hz at -20 to +50 degrees C
External Ant.	50 ohm

SOMMERKAMP ELECTRONIC SAS

CH-6903 LUGANO, P.O. BOX 176
SWITZERLAND

TEL. 91 688543 TELEX: 79314