



## GENERAL

Your new Sommerkamp TS-340 DX is a professional quality Citizens Band Transceiver designed to operate on either AM, Lower Single Sideband (LSB) or Upper Single Sideband (USB). It has many innovative engineering and user functions. Among them, a Sommerkamp plus feature is an amplified AGC circuit, built in to your TS-340. This expands the range of a normal AGC circuit by many times, and is usually found only in the most expensive sets. Your amplified AGC will enable you to hear clearly, even a very weak distant signal, and still allow you to hear a unit close by without overload. The PLL (phase lock loop) frequency synthesizer is the heart of the TS-340 DX's rock steady frequency control. The PLL is self compensating for frequency drift, keeping your TS-340 DX on center channel, every channel. Careful reading of this instruction manual before operation is essential for proper operation and prevention of damage.

## PACKING

This unit has been especially protected for shipment. Open the carton carefully to avoid damage. Examine the unit for any visible damage. If the transceiver has been damaged in shipment, save the box, and packing material, and notify the transportation company.

### RECEIVER

Sensitivity of less than a 1/2 of a microvolt on SSB and AM. A tuned RF stage pulls in even the weakest signals.

A deluxe filter on SSB provides the highest degree of selectivity and rejection of unwanted adjacent channel signals. Ceramic Filters for AM reception deliver over 70 db adjacent channel rejection. Additional receiver features include: variable squelch, clarifier control, integrated circuit audio preamplifier stage, metering automatic noise eliminator.

### TRANSMITTER

High efficiency is obtained through use of select components and sophisticated engineering design. An ALC circuit is employed in the SSB mode to provide maximum "Talk Power" without distortion. The SSB signal is by use of an integrated circuit balanced modulator and PLL synthesizer, to keep you on center channel, every channel. Electronic switching is employed for dependability.

### POWER SUPPLY

Either Positive or Negative ground 12 Volts DC (13.8 VDC E!A) is built in.

# OPERATION OF CONTROLS

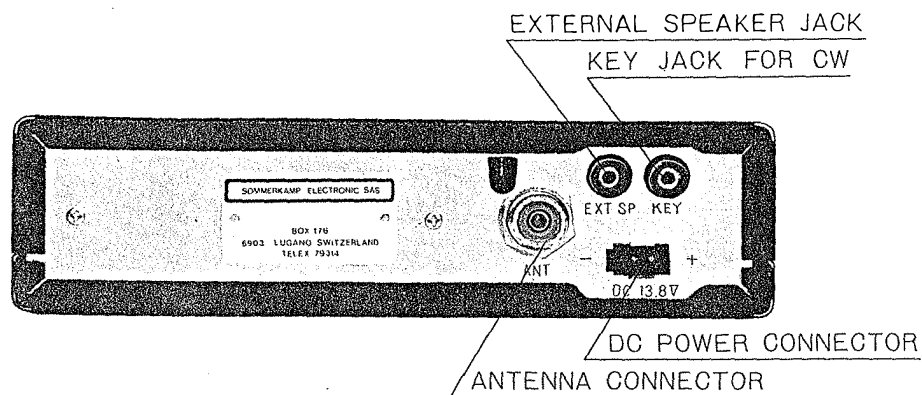
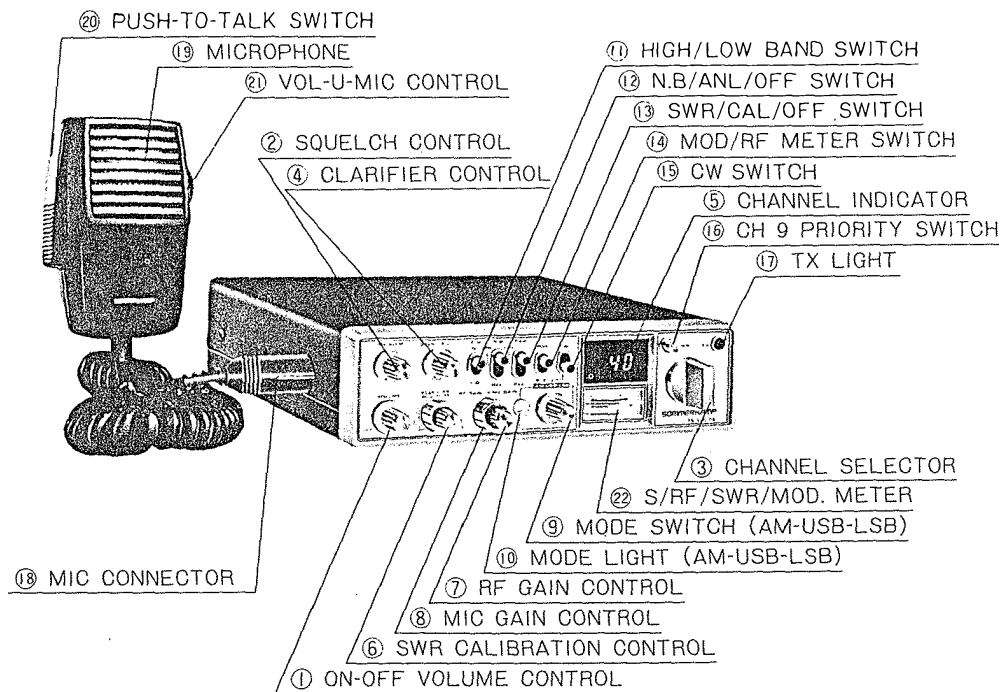

- |             |                      |                     |
|-------------|----------------------|---------------------|
| Front View: | Volume Control       | CAL Switch          |
|             | Squelch              | MOD/RF Meter Switch |
|             | Channel Selector     | CW Switch           |
|             | Clarifier            | CH 9 Priority       |
|             | Channel Indicator    | TX Light            |
|             | SWR/CAL              | MIC Jack            |
|             | RF Gain              | Rear View:          |
|             | Mic Gain             | Antenna Connector   |
|             | Mode Switch          | DC Power Connector  |
|             | Model Light          | Ext PA Speaker Jack |
|             | High/Low Band Switch | Key Jack for CW     |
|             | NB/ANL Switch        | Microphone:         |
|             |                      | Push-To-Talk Bar    |
|             |                      | Vol-U-Mic           |

# FEATURES AND CONTROLS

## VOLUME/POWER ON-OFF

This combination control applies power to your TS-340 DX and adjusts the receiver volume. The switch should be turned clockwise from the "Off" position. You will hear an audible "click". The channel LED and meter will light. To adjust the volume continue advancing the control in clockwise position.

## VOL-U-MIKE

This auxiliary volume control is an extension of the regular front panel receiver volume control. It offers great operating convenience by giving you instant volume adjustment right at your fingertips while you are driving. As this is an extension control, the regular front panel volume must be advanced in order for the Vol-U-Mike to operate.

## SQUELCH CONTROL

The squelch control is used to eliminate background noise when there are no signals present strong enough to overcome the noise. To adjust the squelch control, select a channel where there is no signal. Turn the volume up to normal listening levels. Rotate the squelch control clockwise until the background noise disappears.

## CHANNEL SELECTOR

The channel selector switch is used to select the channel frequency. It automatically adjusts both the transmitter and receiver frequencies, and displays your selection in bold L.E.D. (Light Emitting Diodes), numerals.

## MIC GAIN CONTROL

This control allows you to adjust microphone sensitivity or power to compensate for different operating situations. Maximum microphone sensitivity or power is obtained at the full clockwise position and the control should be set to this point for normal operation and maximum range. Examples of how this control can help to maximize communications effectiveness are as follows: When you are operating at extremely close proximity (within 100 yards or meters) of the other station, reducing the microphone gain may help to eliminate overload and distortion at the other station. When you are operating in an extremely noisy environment such as may be found in the cab of certain large trucks, open sports cars, or around noisy machinery, in order to avoid or reduce the amount of noise that goes out with your signal, you can reduce the microphone gain and by speaking more closely and loudly into the microphone, reduce the ratio of noise to voice.

## RF GAIN CONTROL

This control allows you to adjust the basic sensitivity of the receiver section of the transceiver. It is somewhat like the microphone gain control in that it allows you to compensate for different or varying operating conditions. Maximum RF Gain or receiver sensitivity is obtained at the maximum clockwise position of this control, and the control should be set to this point for normal operation and maximum range. For example, when operating at close proximities to other strong signals, it may be helpful to reduce the RF Gain to avoid overload or distortion or interference from adjacent channels.

## MODE SWITCH FOR LSB-USB-AM

AM transmission is amplitude modulation of the radio frequency carrier with an audio signal (voice). The components of the transmitted signal include the carrier and its two sidebands, upper and lower. For 100% modulation, each sideband contains one-fourth as much power as the carrier. The information transmitted is in the sidebands.

USB transmission is the transmission of the upper sideband only of a single sideband signal. In single sideband transmission, the carrier and one sideband are removed from the transmitted signal. Thus, only one sideband is transmitted.

LSB transmission is the transmission of the lower sideband, only. Rotate the mode selector switch to the desired mode.

## MODE FUNCTION LIGHT

The TS-340 DX has a dynamic 3-way mode function light. In the upper sideband mode the light will be green. The lower sideband mode will show red. The AM mode will show both red and green.

## CLARIFIER

The clarifier is an electronic tuning circuit which allows you to shift the frequency of your receiver. In SSB operation, even small differences in frequencies between stations can cause poor reception. In effect, the clarifier electrically fine tunes the station being received. In AM operation, this acts as a fine tuning circuit.

## TX INDICATOR

Your TS-340 DX is equipped with a LED (light emitting diode) transmit indicator light on the front panel. With the PTT switch on the mike depressed, the LED will light indicating you are in the transmit mode.

## HIGH/LOW BAND SWITCH

For ordinary 40 channel operation, set the switch position to "Low". In the "High" position, your TS-340 DX operates in the frequency range of 27.665 – 28.105MHz (High band 40 channels; 1 through 40).

## S/RF-CAL-SWR METER FUNCTION SWITCH AND CALIBRATION

**NOTE:** THE TRANSCEIVER MUST BE IN THE AM MODE FOR THE SWR FUNCTION TO BE USED.

In the bottom position of the 3-position selector switch, the meter operates normally as signal in, RF output meter. In the center and top positions of this switch, the SWR (standing wave ratio) functions are activated.

To measure SWR, select an open or little used channel as close as possible to the center of the range of channels you plan to operate on. If you plan to operate on all channels 1 through 40, you should select a channel between 17 and 23.

1. Set the function switch to Cal (calibrate).
2. Press the microphone push-to-talk bar and adjust the front panel calibration control so the meter pointer is at the SWR set position which is the small red block at the right side of second meter scale from the bottom. Release the press to talk bar.
3. Set the function switch to the top SWR position.
4. Press the microphone push-to-talk bar and read the SWR measurement on the bottom meter scale.

The SWR scale is calibrated at 1, 1.5, 2, and 3. If the meter pointer stops at 2, for example, it would be correct to say that the SWR is 2 to 1.

For a more complete understanding of SWR and how to reduce it, refer to the section appearing later in this manual titled "Understanding SWR".

## CHANNEL 9 PRIORITY SWITCH

This switch provides instant channel change to emergency Channel 9 without having to rotate the channel selector.

**NOTE:** MOST CHANNEL 9 EMERGENCY MESSAGES ARE TRANSMITTED IN AM, SO IF FOR EXAMPLE YOU ARE OPERATING ON EITHER UPPER OR LOWER SIDEBAND CHANNEL 16 AND YOU WANT TO TRANSMIT OR RECEIVE AN EMERGENCY MESSAGE ON CHANNEL 9 IT WILL BE ADVISABLE TO ROTATE THE MODE SELECTOR TO THE AM POSITION IN ADDITION TO PUSHING THE CHANNEL 9 PRIORITY SWITCH.

## "CW" SWITCH

For operating a Morse key device, set this switch to the "CW" position. Your TS-340 DX is provided with a jack for the CW (Key Jack for CW) on the rear panel.

### S/RF METER

The TS-340 DX is equipped with a large, easy-to-read combination meter. In the receive position, the meter reads the level of the incoming signals. In the transmit position, it indicates relative power output.

**NOTE:** 1. IN THE AM MODE, THE METER WILL READ POWER AT ALL TIMES WHEN THE TRANSMIT BUTTON IS DEPRESSED. ON SSB, HOWEVER, IT WILL ONLY INDICATE RF OUTPUT POWER WHEN YOU MODULATE THE SIGNAL.  
2. IN THE SSB MODE, NO METER CAN FOLLOW THE RAPID VOICE PEAK POWER ATTAINED. THEREFORE, WHILE THE TRANSMITTER IS DEVELOPING MUCH MORE POWER THAN ON AM, THIS ADDITIONAL POWER WILL NOT BE FULLY REFLECTED ON THE METER.

### MODULATION/RF METER SWITCH

Allows either relative RF (Radio frequency) output or modulation output to be monitored while transmitting.

### NB/ANL (NOISE BLANKER/AUTOMATIC NOISE LIMITER) SWITCH

The TS-340 DX is equipped with both noise blanker and ANL circuits for maximum noise suppression and clear reception.

### DC CONNECTOR

This connector is used to supply power to your TS-340 DX. The plug-in feature allows easy removal for security purposes or for moving the transceiver to another vehicle.

### KEY JACK FOR CW

For attaching optional CW (Morse key) device, simply plug it into this jack.

### EXTERNAL SPEAKER JACK

You may add any 8-16 ohm external speaker. Simply plug your accessory speaker into the jack.

**NOTE:** INSERTING THE 3.5MM PLUG WILL AUTOMATICALLY DISCONNECT THE INTERNAL SPEAKER.

### ANTENNA CONNECTOR

A standard SO-239 type connector is supplied for attaching either mobile or base antennas.

### MICROPHONE

The receiver and transmitter are controlled by the press-to-talk switch on the microphone. To transmit, simply press in this switch. Release the switch to receive. When transmitting, hold the microphone 3 to 4 inches from your mouth and speak clearly at normal voice levels. The TS-340 DX uses a newly designed high level output microphone. It delivers maximum talk power.

### NEGATIVE GROUNDING

Almost all cars and most trucks are negative ground. Your TS-340 DX is designed to operate on the negative ground only. In the negative ground systems, the minus (-) pole of the battery is attached to the car body, engine block, etc.

### NEGATIVE GROUND HOOKUP

Attach the red (fused) wire to the fuse block terminal or any convenient plus (+) lead. Devices operated by the ignition key such as the radio, light, etc., are best since when you turn the ignition off, the unit will be turned off. Attach the black lead to the car body via any convenient method.

**NOTE:** MANY NEWER CARS USE PLASTIC DASH PIECES. MAKE SURE THE SCREW OR CONTACT YOU CHOOSE IS ATTACHED TO THE METAL FRAMEWORK OF THE CAR.

### GENERAL OPERATING INSTRUCTIONS

**CAUTION:** NEVER OPERATE THIS UNIT WITHOUT AN ADEQUATE ANTENNA SYSTEM OR LOAD. ANTENNA SWR SHOULD NOT EXCEED 3:1. FAILURE TO FOLLOW THESE RECOMENDATIONS COULD RESULT IN DAMAGE TO THE RE OUTPUT TRAN-SISTOR.

1. Make sure the proper connections have been made for antenna system, power cable, and microphone.
2. Set the Squelch Control fully counterclockwise.
3. Set the RF Gain fully clockwise.
4. Set the Mic Gain fully clockwise.
5. Set the Mode Switch to the desired mode.
6. Rotate the Volume Control clockwise. You will hear an audible "click", and the meter and channel lights will come on. Continue rotating clockwise to desired listening level.
7. With no signal present, rotate the Squelch Control clockwise until the rushing noise disappears.
8. Set the Channel Selector to the desired channel.
9. To Transmit, simply press and hold the push-to-talk bar on the microphone a few inches from your mouth and speak in a normal tone of voice.

**FAILURE TO MAKE THE PROPER CONNECTION COULD RESULT IN UNIT DAMAGE.**



## ANTENNA REQUIREMENT

This transceiver will operate with any standard 52 ohm ground-plane, vertical, mobile whip, long wire or other CB antenna. A standard SO-239 type connector is provided on the back panel for use with popular PL-259 antenna plug.

## ANTENNA INSTALLATION

When the TS-340 DX is used as a base station, any Citizens Band beam, dipole, ground-plane or vertical antenna may be used. A ground-plane type will provide greater coverage, and since it is essentially non-directional, it is ideal in base station to mobile operation. From base station to base station, or point to point operation, a directional beam will give greater distance even under the adverse conditions.

## MOBILE ANTENNAS

A vertical whip antenna is best suited for mobile use. A non-directional antenna must be used for best results in any case. The base loaded whip antenna will normally provide effective communication. For greater range and more reliable operation, a full quarter wave-whip may be used. Either of these antennas use the metal car body as a ground plane, and the shield of the base lead as well as the metal case of the transceiver should be grounded. A standard antenna connector (type SO-239) is provided on the transceiver for easy connection to a standard PL-259 cable termination.

## MOBILE INSTALLATION

A location in the car or truck should be chosen carefully for convenience of operation and non-interference with normal driving functions. Mounting may be under the dash or instrument panel or any place a secure installation can be made. An easy-release mounting bracket is supplied and additional perforated straps or brackets may be used as desired. The 12 Volt cable may be connected to any convenient terminal, but preferably to the ignition switch to prevent unauthorized persons from operation of your unit. With this method, the unit will only operate when your key is turned on. Engine ignition interference should not be a problem, and vehicles equipped with standard broadcast radios should have enough suppression to eliminate ignition interference. If interference is present, any skilled auto radio repairman should be able to eliminate it for you.

## BASE STATION OPERATION

For base station use, a suitable regulated 2.5 AMP power supply is recommended. When a power supply is used, simply connect the red (+) and black (-) terminals on the power supply of the (+) and (-) leads on your TS 340 DX

# MOUNTING INSTRUCTIONS

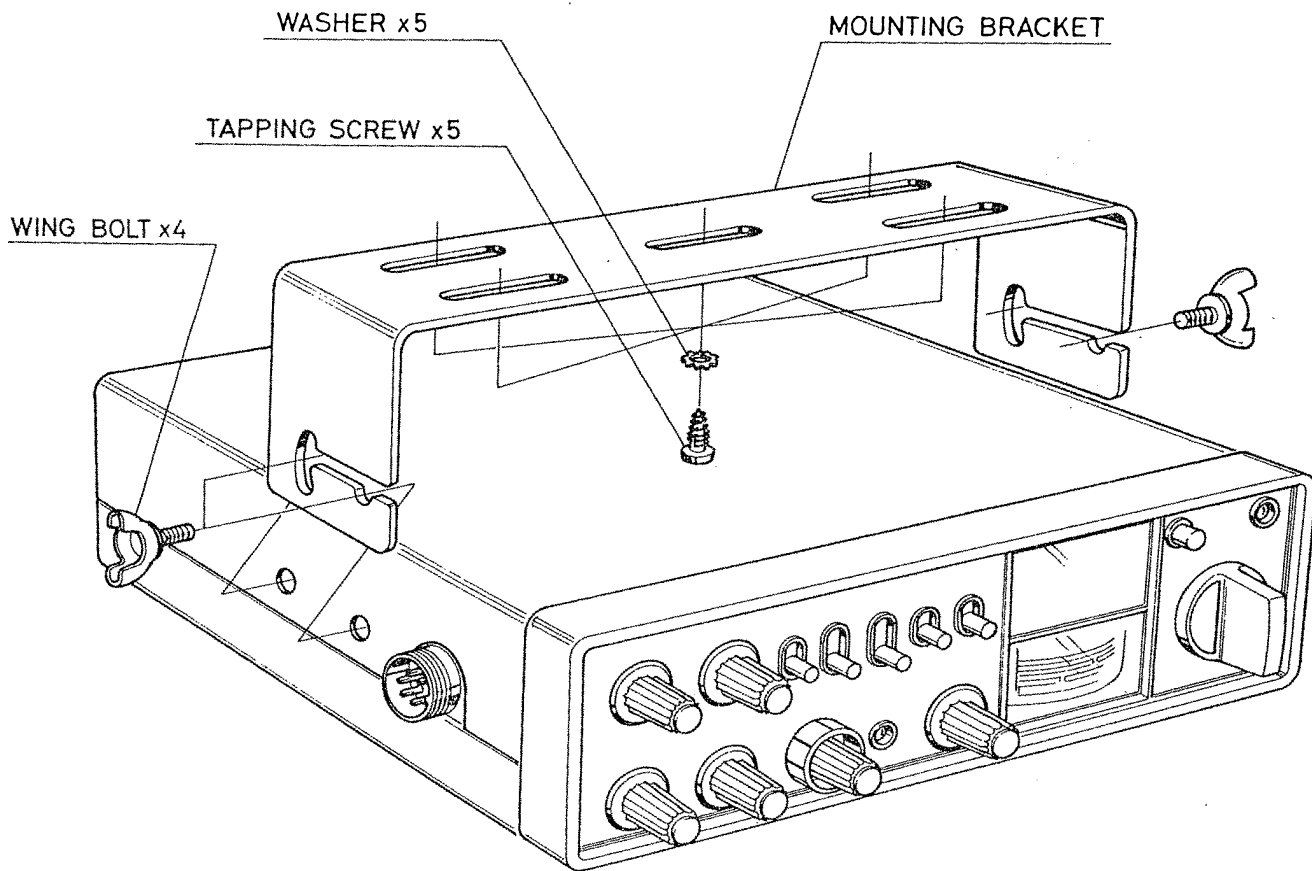

# SPECIFICATIONS

## GENERAL

1. Semiconductors : 22 Transistors, 2 FET, 10 IC's, 54 Diodes and 3 LED
2. Frequency Range : Low Band 1 – 40 26.965 – 27.405MHz  
High Band 1 – 40 27.665 – 28.105MHz
3. Modes of Operation : AM, Lower Sideband and Upper Sideband
4. Controls : Volume Control with power on-off switch  
: Variable Squelch Control  
: Mike Gain Control.  
: RF Gain Control.  
: SWR/CAL Control.  
: Mode Selector Switches  
: Clarifier Control  
: Channel Selector Switch  
: Noise Blanker/ANL Switch.  
: Meter Select Switch.  
: CH-9 Priority Switch  
: CW Switch
5. Connectors and Jacks : High/Low Band Switch  
: Microphone Connector  
: Coaxial type Antenna Connector  
: Key Jack for CW.  
: External Speaker Jack  
: DC Power Jack
6. Speaker : 3-1/2 inches, 8 ohms
7. Microphone : Dynamic Microphone (500 Ohms)
8. Power Supply : 13.8VDC
9. Dimensions : 8" (W) x 1-1/8" (H) x 7-5/16" (D)
10. Weight : 4 LBS 07 OZS

## RECEIVER

1. Sensitivity at S/N 10dB : AM. . . . . 0.5uV SSB. . . . . 0.2uV
2. Selectivity : AM. . . . . 5KHZ SSB. . . . . 2.2KHZ
3. AGC Figure of Range : 80dB
4. Squelch Range : 0.5uV – 1000uV
5. Audio Output Power : 3 Watts
6. Distortion at input 100uV : 6%
7. Audio Frequency Response : 300 – 2200HZ
8. Spurious Response : More than 45dB spurious signal is required to produce the same amount of audio output as the desired receive signal.
9. IF Frequency : 9.785MHZ
10. Current Drain no audio : 500mA

## SSB TRANSMITTER

1. RF Output Power : 12 Watts PEP
2. Carrier Suppression : More than 40dB
3. Unwanted Sideband Suppression : More than 50dB
4. Harmonic Suppression : More than 60dB
5. Current Drain : 850mA

## AM TRANSMITTER

1. RF Output Power : 4 Watts
2. Modulation Capability : More than 80%
3. Harmonic Suppression : More than 60dB
4. Current Drain : 1800mA

# ALIGNMENT INSTRUCTIONS

## 1. RECEIVER

- 1) Set the Mode Switch to AM, Volume Control at maximum, Squelch at minimum and Clarifier in the center.
- 2) Set the SSG on Channel 40 and Channel Selector of the unit on Channel 40.  
Then, connect the Power Supply and 8 ohms Dummy Load to the transceiver unit.
- 3) Feed the signal from the SSG and set the audio output for a peak reading by adjusting T-1, T-2, T-3, and T-4.  
In this case be sure that antenna input should be less than  $1\mu\text{V}$  at the AF standard output power. Also, make sure that the audio on the oscilloscope is a sine wave.
- 4) Set the antenna input at  $1\mu\text{V}$  so that the antenna power may be more than 0.5 watt at the maximum volume of all channels.
- 5) Set the antenna input at  $1,000\mu\text{V}$  so that the output power should be more than 3.0 watts at the maximum volume.
- 6) Set the antenna input to  $50,000\mu\text{V}$  and the low frequency output to 0.5 watt by volume control. Then, decrease the antenna input until the low frequency output stays 10 dB lower. Be sure that the antenna input then should be less than  $5\mu\text{V}$ .
- 7) Set the antenna input to  $100\mu\text{V}$  and the meter indication to 9 by VR-2.
- 8) Set the volume control and squelch control at maximum, and set the tight squelch by VR3 so that the output from speaker is heard when the antenna input is increased upto  $1,000\mu\text{V}$ .
- 9) Set the antenna input to  $0.7\mu\text{V}$  and be sure that the low frequency output should be over 10 dB more when the modulation of the SSG is turned off at the normal output.
- 10) Set the Mode Switch to USB, Volume Control at maximum, Squelch at minimum and Clarifier in the center. Tune off the modulation of the SSG and remove the frequency by 1 KHz.
- 11) Make sure that the maximum sensitivity should be less than  $1\mu\text{V}$ .
- 12) Make sure of AGC like with AM.
- 13) Set the antenna input to  $0.2\mu\text{V}$  and keep the AF output to be over 10 dB lower when the antenna input is turned off at the normal output.

## 2. TRANSMITTER

- 1) Connection of test equipment.
  - \* Power supply at 13.8 VDC.
  - \* Connect a Power meter, oscilloscope frequency counter, spectrum analyzer and P-P RF volt meter to the RF output connector.
  - \* Connect an AF oscillator and AF volt meter to the microphone connector.
- 2) Power adjustment.
  - \* Set the mode switch to AM.
  - \* Adjust T-5, 8, 9, L-12, and L-3 for the maximum point.
  - \* Adjust L-4 for 3.6W output.
  - \* Adjust L-2 to increase 2nd harmonic.
- 3) Frequency-Make sure every channel stays within  $\pm 800\text{Hz}$ .
- 4) Modulation Limiter Adjustment.
  - \* Put in 1KHz and 20mV signal from AF oscillator and adjust VR7 for 90% modulation
- 5) Modulation capability.
  - \* Put in 1kHz signal by AF oscillator and get 90% modulation for the minus side. The plus side should be over 80%.
- 6) SSB.
  - \* Set the mode switch to USB.
  - \* Put in two-tone signal of 1KHz and 1.6KHz by two AF oscillators.
- 7) ALC alignment.
  - \* Adjust the two-tone signal of AF oscillator for 3 W RF power output.
  - \* Adjust VR-11 for 11 W PEP RF power output when the two-tone signal is increased by 20 dB.
- 8) Carrier suppression.
  - \* Cut off the two-tone signal and make sure the output level of the carrier is below  $-40\text{ dB}$ .
  - \* Set the mode switch to LSB and do the same.

# YOU AND YOUR ANTENNA

Three main components comprise a typical Citizensband installation. They are: your transceiver, an antenna, and the coaxial cable which connects the antenna to the transceiver. It is important that all three pieces are installed correctly to give the best possible range and reliable performance. We hope this pamphlet will be helpful for you to realize the maximum performance of your installation.

## ANTENNA

For several reasons, it is impossible to exactly PRE-TUNE an antenna at the factory. A general range of tuning is done which may suffice, but for best performance, an antenna should be turned after it is installed.

Most antennas have some form of tuning capability. Usually, this involves the whip section sliding into a coil, spring, or metal section. This allows the antenna to be adjusted to the exact frequency desired. We cannot stress enough the importance of tuning your antenna. The measure of an antenna's performance is its "SWR" (standing wave ratio).

## "COAX" CABLE

Coax cable is used in all Citizensband installations. This cable transfers the power from your transceiver to the antenna. The output of your transceiver is 50-52 ohms. Your antenna is designed to be 50-52 ohms. For this reason, RG58/U or RG8/U cable is used because it also is 52 ohms and matches the antenna to the unit. The frequency of the antenna is very important in this area because a mis-tuned antenna can disrupt the system balance. If this balance is disrupted, standing waves are generated on the coaxial cable, which results in a loss of power in your transceiver.

## UNDERSTANDING SWR (Standing Wave Ratio)

In theory, your transceiver has a 50 ohm output and your antenna is 50 ohms. If a 50 ohm cable (such as RG58/U or RG8/U) is used, all the power from your transceiver will be transmitted via the coaxial cable and radiated by the antenna. Under these conditions, the SWR (standing wave ratio) of your antenna system would be 1:1. In practice, the antenna must be 50 ohms and tuned to the exact channel. This condition seldom exists and standing waves are set up on the cable. This SWR robs you of power and likewise range. While 1:1 is not always possible to attain, you should tune your antenna system so the SWR does not exceed 1.5 to 1 or at maximum 2 to 1. Here are some examples of the power losses for various SWR ratios:

<u>SWR</u>		<u>Power Losses</u>
1:1	=	0
1.3:1	=	2%
1.5:1	=	3%
1.7:1	=	6%
2:1	=	11%
3:1	=	25%
4:1	=	38%
5:1	=	48%
6:1	=	55%
10:1	=	70%

### TUNING YOUR ANTENNA

For optimum performance, an SWR meter should be used to tune the antenna. However, since this meter may cost from \$15.00 to \$30.00, not everyone may want to invest in its purchase. If possible, borrow one. If you are unable to borrow one, the RF output meter on your transceiver can be used as a GUIDE to antenna turning. While it is not 100% accurate, it is generally better than no tuning at all. Always tune your antenna in an open area. Wires, metal and copper tubing if nearby can effect the tuning. Never tune an antenna inside a garage, under a metal car port, next to a metal truck, etc.

#### A. USING YOUR TRANSCEIVER OUTPUT METER AS A TUNING GUIDE

After installing your antenna system, place the whip halfway into its receptacle and turn your transceiver to Channel 20. Depress the switch on your transceiver microphone, and make note of the reading on your RF output meter. Loosen the adjustable whip section and move it 1/8 to 1/4 inch down. Again depress the transmit switch, if the reading is the same or lower continue moving the whip down 1/4 inch at a time until the LOWEST reading is obtained on your transceiver RF meter. If the reading was higher, move the whip up 1/4 to 1/2 inch the first time and 1/8 to 1/4 inch thereafter until the LOWEST reading is obtained on the RF meter. That's right . . . .

THE LOWEST READING. Your RF output meter is a voltage sensing device. It is installed in the RF output circuit and senses the voltage near the antenna terminal. In a perfectly tuned system all of the voltage is transferred from the output transistor and passed to the antenna. As an example, let's use the figure 10. If there is SWR on the line, the forward voltage is 10 and a reverse voltage appears (let's say it's 2). The meter circuit now sees 20 and shows a higher reading. You can see that because of the way most RF output meters work, the LOWER your RF output meter reads the better your antenna is tuned. Of course, if the meter reads less than 1/2 scale, it may indicate a problem in your set and should be checked. Similarly, an extremely high reading may indicate a problem in your antenna. An RF output meter can tell you much . . . especially if you know how to use it.

#### B. TUNING YOUR ANTENNA WITH AN SWR METER

Using an SWR meter is the most accurate way to tune an antenna.

Connect the SWR meter as close as possible to the back of the transceiver. Use a double male connector or a very short piece of RG58/U with connectors on each end.

Place the adjustable whip halfway into its receptacle. Set your transceiver to Channel 20. Measure the SWR following instructions supplied with the meter. After the first measurement, move the whip down 1/8 to 1/4 inch and repeat ALL the steps again. If the SWR is lower,

continue the process moving the whip down 1/8 to 1/4 inch at a time until the lowest reading is obtained. If the SWR is higher, raise the whip 1/4 to 1/2 inch the first time and 1/8 to 1/4 inch thereafter until the lowest SWR is obtained. Note, if the reading continues falling but you have reached farthese point down that you can go with the whip, the whip may be too long. To verify this, put the Channel Dial to Channel 1 and measure the SWR. Next, put the channel dial to Channel 40 and measure the SWR. IF THE SWR WAS LOWEST ON CHANNEL 1 AND HIGHEST ON 40 THE WHIP SECTION IS TOO LONG. Carefully cut 1/4 to 3/8 inch from the whip section and re-measure Channels 1, 20, and 40. If the SWR is still lowest on Channel 1 continue trimming the whip by removing 1/8 to 1/4 inch at a time until the lowest SWR is obtained on Channel 20. DO NOT GET OVERANXIOUS. YOU CANNOT REPLACE A SECTION ONCE IT IS CUT OFF. If you exceed slightly the best tuning for Channel 20, the whip may be raised 1/8 to 1/4 inch at a time to obtain the best SWR on Channel 20.

WARNING: DO NOT CUT THE WHIP USING THE "POWER OUTPUT METER TUNING METHOD". YOU MUST USE AN SWR METER TO ACCURATELY DETERMINE THE SWR.

Every six months or so, re-check the SWR. Car washes, rod grime, and chemicals can effect the mechanical connections of an antenna and corrode them. This corrosion can cause poor electircal connections and lead to high SWR. The correction of this problem is usually accomplished by cleaning of the metal connection parts with a wire brush.

## HELPFUL HINTS

1. High SWR robs you of range and puts a strain on your output transistor. ALWAYS TUNE A NEW ANTENNA.
2. Never tune your antenna in a closed area (garage, under a metal car port, etc.) as may result.
3. MAKE SURE ALL MECHANICAL CONNECTIONS ARE TIGHT.
4. DON'T SMASH OR SHARPLY BEND THE COAX CALBE – it should remain generally round to do its job properly.
5. TIGHTEN YOUR PL-259 CONNECTOR OCCASIONALLY – road vibration has a tendency to loosen it which can cause output transistor problems.
6. PERIODICALY (every 6 months) re-check your SWR. Corrosion and road grime may rob you of performance.
7. PERIODICALLY check your coax cable for wear. A broken or loose wire could cause RF output transistor failure.

This information was produced to help you understand the installation and maintenance of your antenna and cable feed system. Many field problems have been traced io problems such as the above. They can lead to eventual failure of the RF output transistor in your transceiver. Careful installation and maintenance can prevent these problems.

## ACCESSORY JACK

The 7-pin DIN standard accessory jack has the following connections:

1. Internal speaker (Z 8 Ohm)
2. Audio detector output
3. Audio output (Z 8 Ohm-32 Ohm)
4. Microphone input (Z 600-10 K Ohm)
5. External Vol. Control
6. +12 Volt
7. transmit/receive switching

Case = ground

Always operate the transceiver with the shortening plug inserted in the accessory jack, or with the following external connections:

### 1. Headset or Telephoneset with PTT.

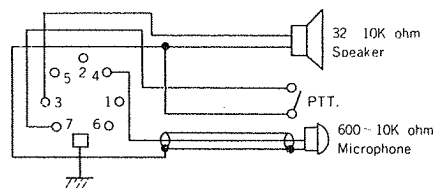

### 2. External microphone

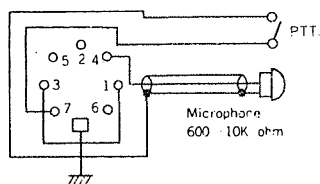

### 3. Headset or Telephoneset with VOX.

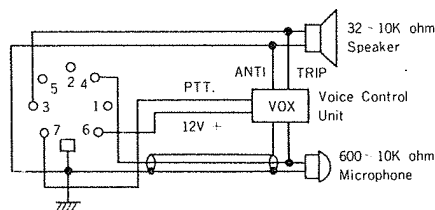

### 4. External microphone/speaker with PTT.

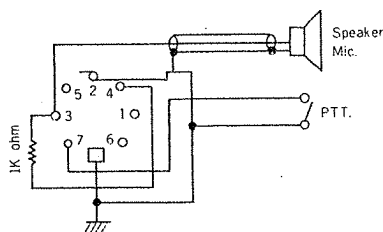

### 5. PARROT 76

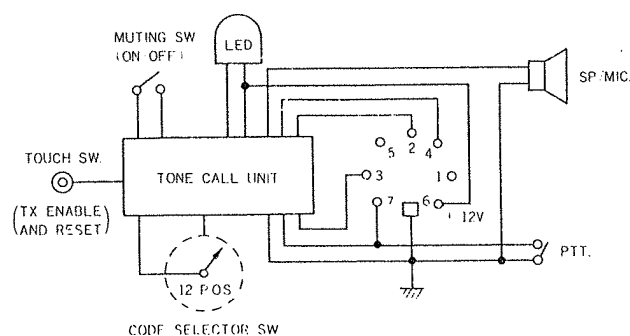



# CIRCUIT DIAGRAM

