

J.F.K.

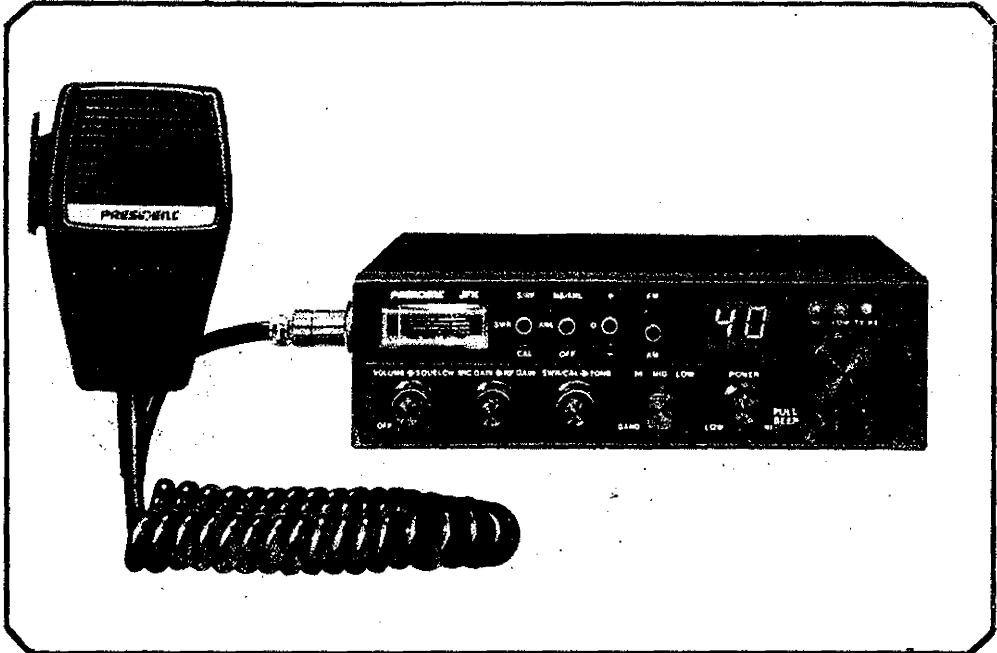

PRESIDENT™

MANUEL DE MAINTENANCE

J. F. K.

CARACTERISTIQUES COMMERCIALES

GENERALES :

Bande de fréquences : 26,965 MHz à 27,405 MHz
Nombre de canaux : 40
Ecart entre canaux : 10 KHz
Classe d'émission : A3E (AM); F3E (FM);
Tension d'alimentation : 13,2V (10,8V⁻ à 15,6V⁻)
Marge de température : - 10° C à + 55° C
Impédance d'antenne : 50 Ohms

EMETTEUR :

Ecart de fréquence : moins que +/- 800 Hz
Puissance d'émission : 4 W crête (1W en AM - 4W en FM,
Impédance du microphone : 500 Ohms
Puissance émise dans le canal adjacent : inférieure à 20 microwatts.

RECEPTEUR :

Première F.I. : 10,695 MHz
Deuxième F.I. : 4,55 KHz
Impédance du haut-parleur incorporé : 16 Ohms
Puissance de sortie B.F. : 2W
Sensibilité : meilleure que 12 dB/microwolt (f, e, m)

ALIGNEMENT DU SYNTHETISEUR DE FREQUENCE

1) ALIGNEMENT NECESSAIRE :

- a- Oscilloscope (0 - 50MHz)
- b- Alimentation continue (13.8V)
- c- Voltmètre continu (10V maximum, 100K Ohm/Volt)
- d- Fréquencemètre (0 - 50Mhz)

2) PROCEDURE D'ALIGNEMENT :

ORDRE	MODE	REGLAGE	OPERATION
1	CH : 1 MODE : RX	L 17	Connecter le + du Voltmètre continu à TP1 (R 72). Régler L 17 pour obtenir $1,2V \pm 0,1V$ sur le voltmètre par rapport au négatif.

3) SYNOPTIQUE DU BANC DE MESURE :

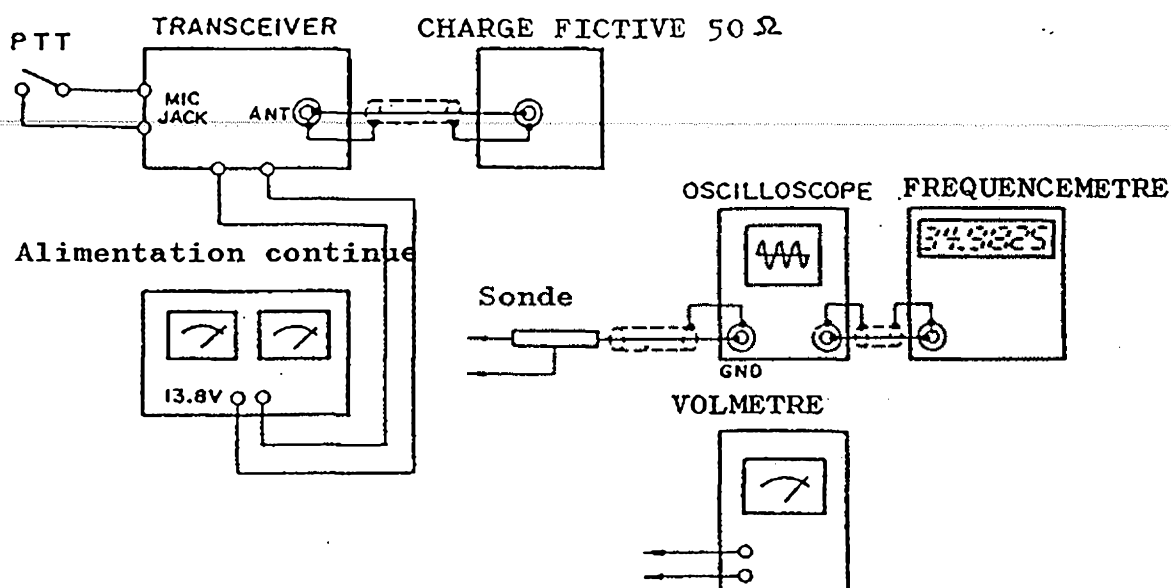

ALIGNEMENT DE L'EMETTEUR

1) EQUIPEMENT NECESSAIRE :

- a- Oscilloscope (0 - 50MHz)
- b- Alimentation continue (13.8V, 2 - Amp.)
- c- Voltmètre BF position AC
- d- Meter Wattmètre HF
- e- Fréquencemètre (0 - 30MHz)
- f- Excursiomètre

- g- Charge fictive 50 Ohm
- h- Générateur
- i- Alimentation continue

S/RF-SWR-CAL : S/RF, MIC GAIN: MAX

2) PROCEDURE D'ALIGNEMENT :

ORDRE	MODE	REGLAGE	OPERATION
1	MOD. : NON CH : 19 POWER: MAX AM-FM: AM	L19, L20 et L18	Premièrement descendre le noyau de L 18 au minim. Relier l'oscilloscope à TP 2 (R 79) Régler les noyaux pour obtenir le maximum de lecture sur l'oscilloscope (compris L 18)
2	IDEM 1	L20, L15 et L14	Relier le wattmètre à la sortie ANTENNE (J 201) Régler les noyaux pour obtenir le maximum de déviation sur le wattmètre.
3	IDEM 1 CH.1 CH.40	L11	Régler L11 pour obtenir le minimum de différence entre le canal 1 et le canal 40
4	IDEM 1	VR3	Régler VR3 pour obtenir "S9" sur le vumètre
5	IDEM 1 AM - FM : FM CH : 1	VR801	Relier l'excursiomètre FM à la sortie antenne et relier le générateur à la prise micro - Régler ce dernier pour 30 mV de sortie Régler VR801 pour obtenir 4Khz de déviation.
6	IDEM 1	VC1	Relier le fréquencemètre en sortie Régler VC1 pour obtenir 27,185 Mhz.

3) SYNOPTIQUE DU BANC DE MESURE :

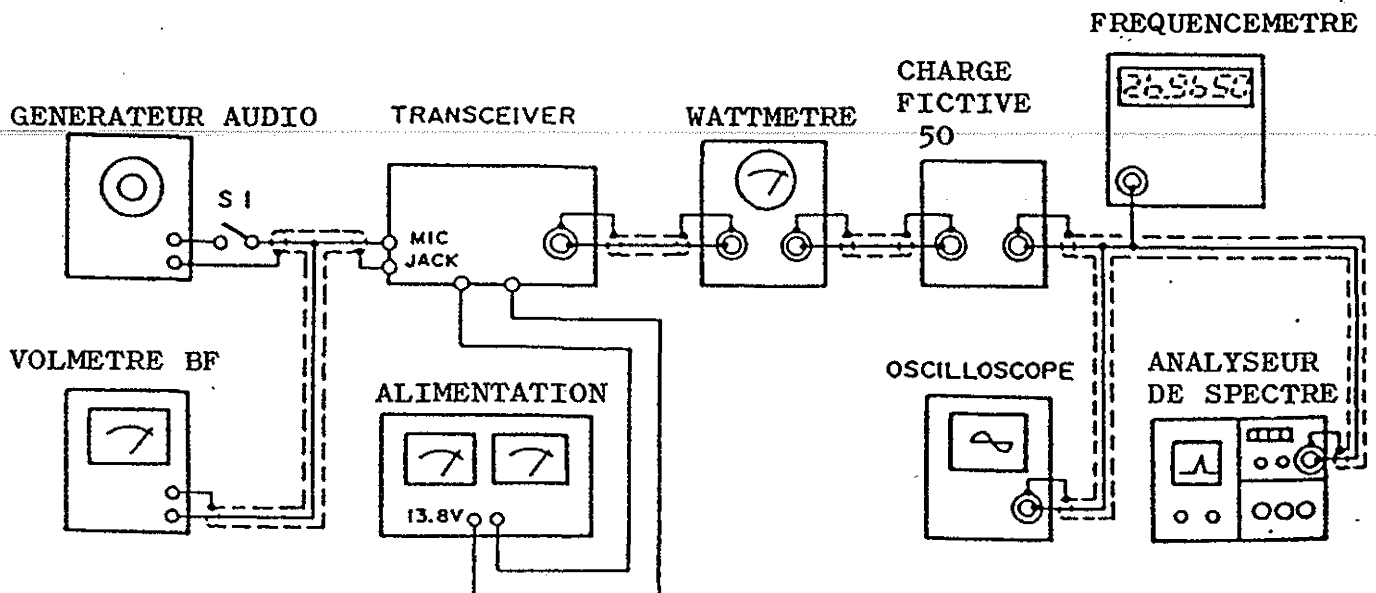

ALIGNEMENT DU RECEPTEUR

1) EQUIPEMENT NECESSAIRE :

- a- Oscilloscope (0 - 50 MHz)
- b- Alimentation continue (13.8V, 2-Amp.)
- c- Générateur HF (27MHz Band, 1000Hz, 30% AM Modulation et 50 Ohms Impédance)
- d- Voltmètre BF (AC)
- e- Atténuateur

2) PROCEDURE D'ALIGNEMENT :

ORDRE	M D D E	REGLAGE	OPERATION
1	CH: 19 VOL: MAX SQ: MIN AM-FM: AM	L7 - L6 - L5 L4 - L1	Relier le générateur à la prise antenne J 201 et le voltmètre BF au Jack Ext. SPEAKER. Ajuster les noyaux pour obtenir le maximum de déviation sur le voltmètre BE.
2	IDEM 1 CH: 1 PUIS CH: 40	L2 - L3	Ajuster L2 pour obtenir le maximum de niveau de bruit en sortie Canal 1 - Puis ajuster L3 par la même méthode de réglage que L2. Canal 40 . Réajuster L2 pour obtenir le même niveau de bruit Canal 1 qu'au réglage de L3.
3	IDEM 1 excepté SQ: MAX	VR 2	Régler le niveau de sortie du générateur à 1000 μ v Régler VR 2 pour obtenir 2v avec le voltmètre B.E
4	IDEM 1	VR 1	Régler le niveau de sortie du générateur à 100 μ v Régler VR 1 pour ajuster le S.Mètre à "S9".
5	IDEM 1 excepté AM-FM: FM	L801	Régler "le volume" pour obtenir 2v sur le voltmètre BF - Régler le niveau du générateur à 1000 μ v - Régler L801 pour obtenir le maximum de déviation ou le voltmètre BF.

3) SYNOPTIQUE DU BANC DE MESURE :

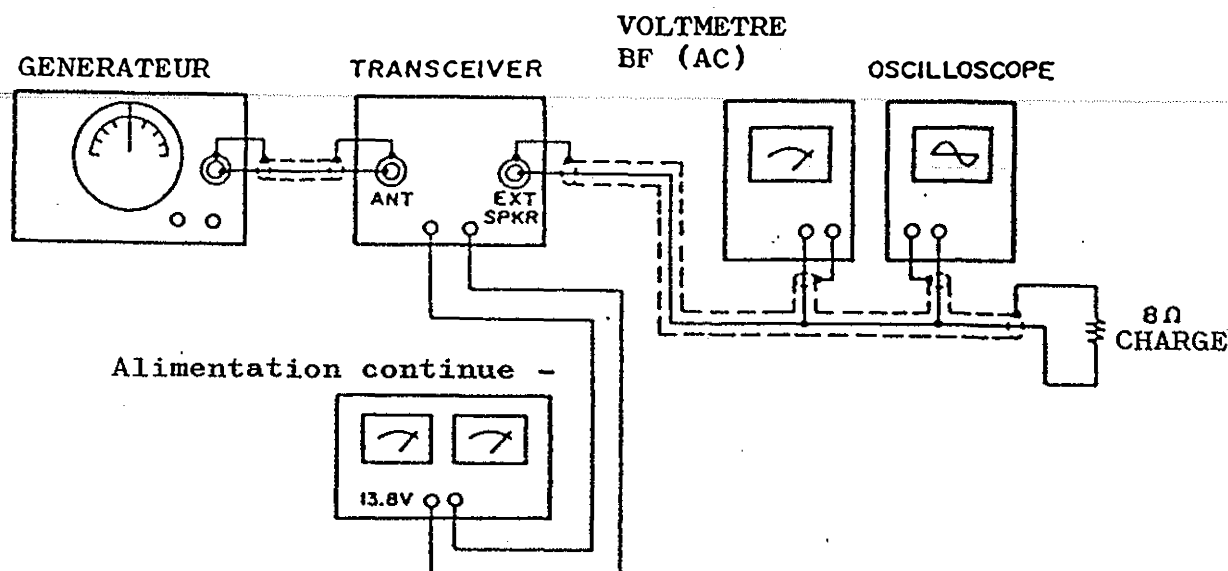

EMPLACEMENT DES POINTS D'ALIGNEMENT

PC-713

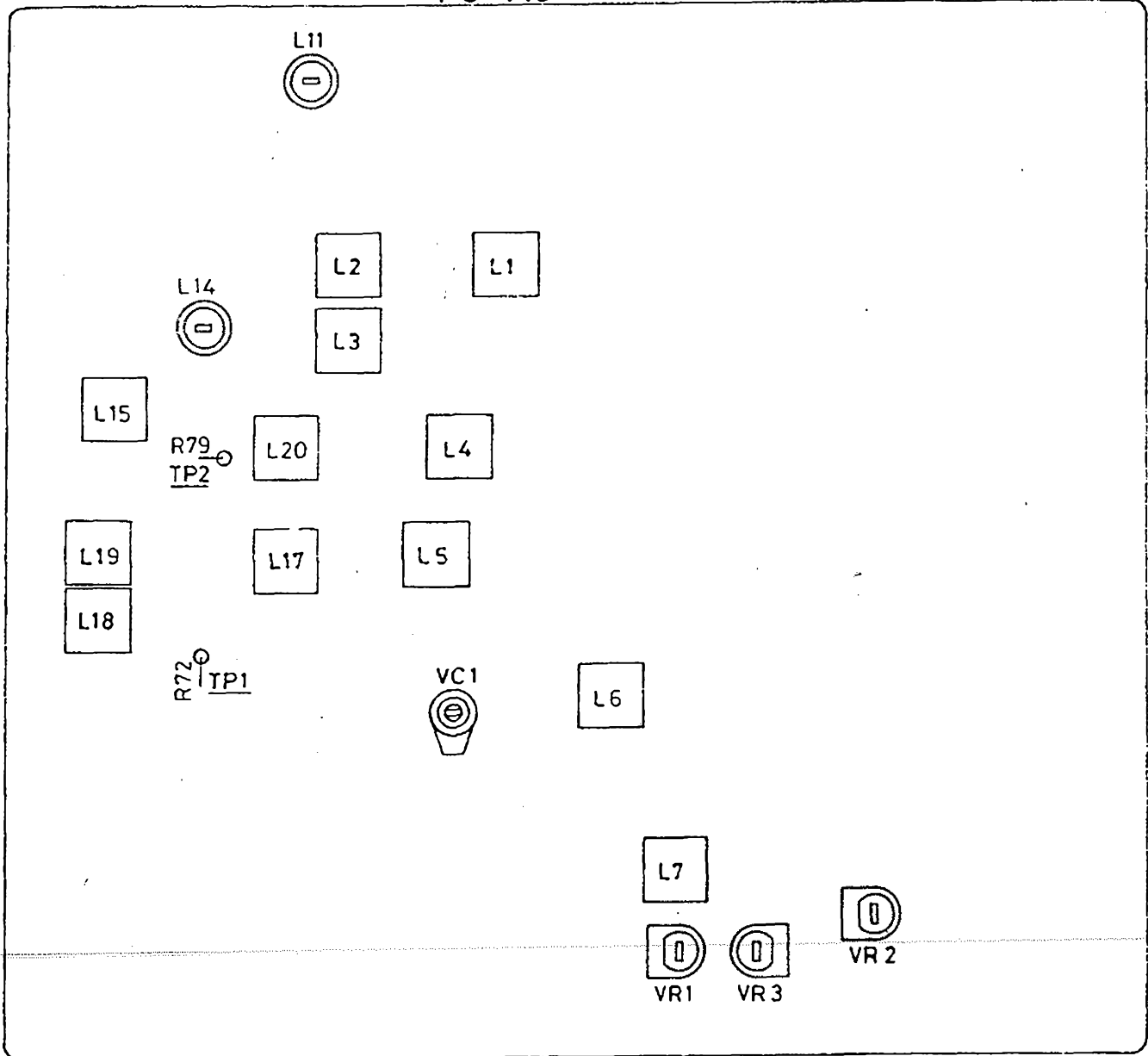

PC-904

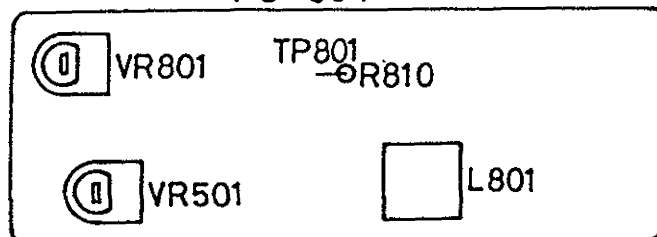

FREQUENCE DE L'OSCILLATEUR LOCAL

CH	Frequence [MHz]		
	Antenne	VCO. RX	VCO. TX
1	26.965	16.270	16.725
2	26.975	16.280	16.735
3	26.985	16.290	16.745
4	27.005	16.310	16.765
5	27.015	16.320	16.775
6	27.025	16.330	16.785
7	27.035	16.340	16.795
8	27.055	16.360	16.815
9	27.065	16.370	16.825
10	27.075	16.380	16.835
11	27.085	16.390	16.845
12	27.105	16.410	16.865
13	27.115	16.420	16.875
14	27.125	16.430	16.885
15	27.135	16.440	16.895
16	27.155	16.460	16.915
17	27.165	16.470	16.925
18	27.175	16.480	16.935
19	27.185	16.490	16.945
20	27.205	16.510	16.965
21	27.215	16.520	16.975
22	27.225	16.530	16.985
23	27.255	16.560	17.015
24	27.235	16.540	16.995
25	27.245	16.550	17.005
26	27.265	16.570	17.025
27	27.275	16.580	17.035
28	27.285	16.590	17.045
29	27.295	16.600	17.055
30	27.305	16.610	17.065
31	27.315	16.620	17.075
32	27.325	16.630	17.085
33	27.335	16.640	17.095
34	27.345	16.650	17.105
35	27.355	16.660	17.115
36	27.365	16.670	17.125
37	27.375	16.680	17.135
38	27.385	16.690	17.145
39	27.395	16.700	17.155
40	27.405	16.710	17.165

SYNOPTIQUE

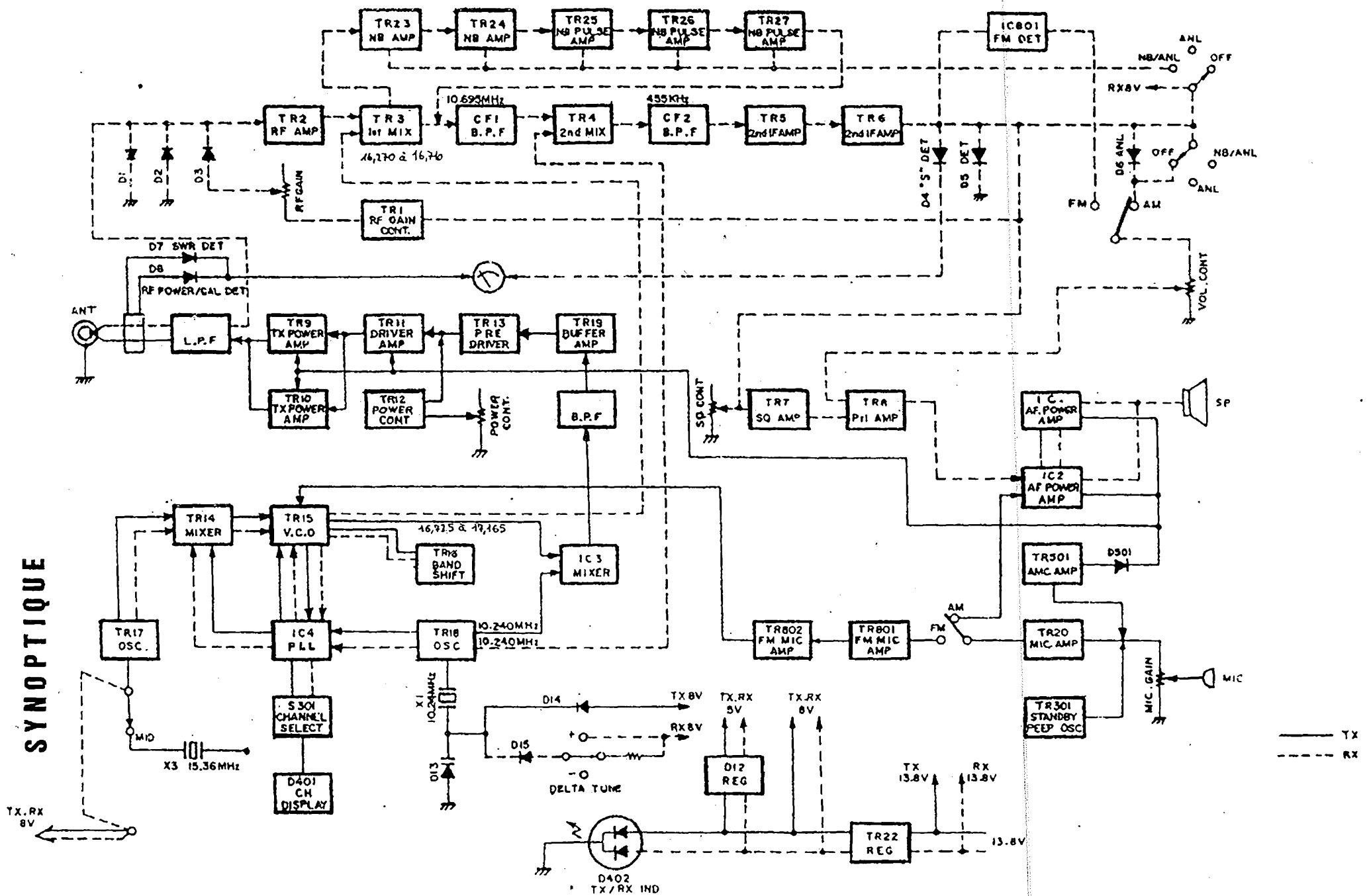

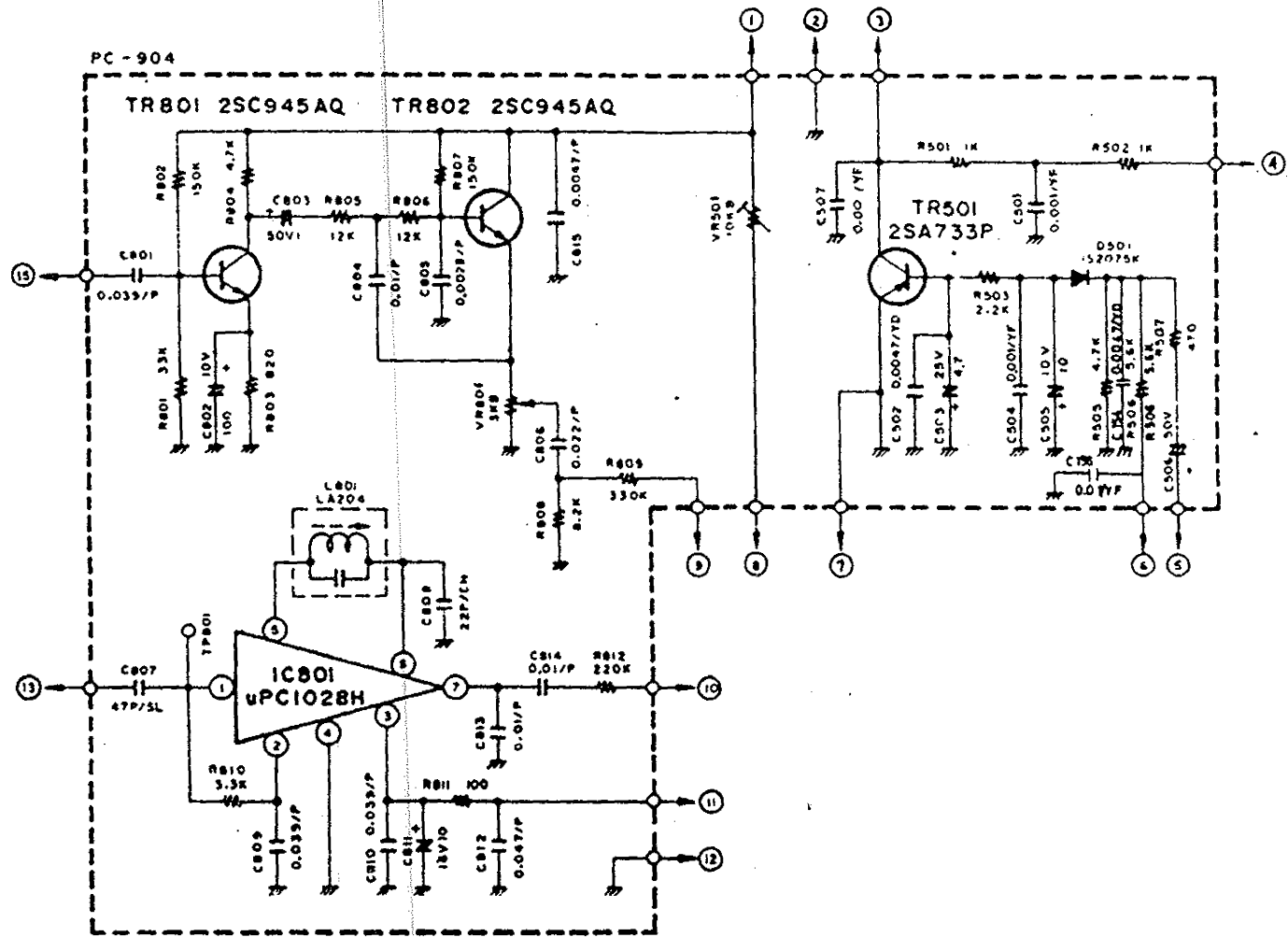

(FM/AM / ROGER-BEEP)

BROCHAGE DES SEMI-CONDUCTEURS



CIRCUITS INTEGRES

MPC1028H

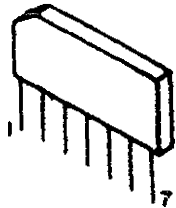

MB3712

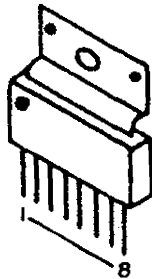

TA7310P

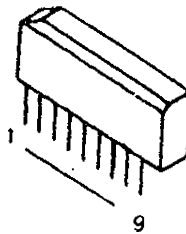

μPD2816C

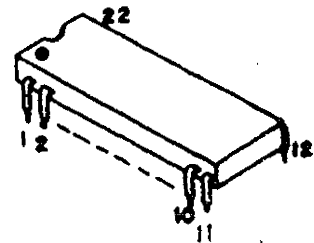

TRANSISTORS

2SA733
2SC945
2SC1674
2SC1675



2SC1969
2SC2029



2SC1957



2SD471



DIODES

IN60 1S2888
1S2075 RD51EB2
IN4003 RD10EB1

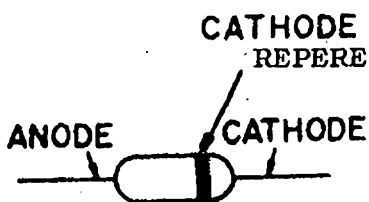

UR202

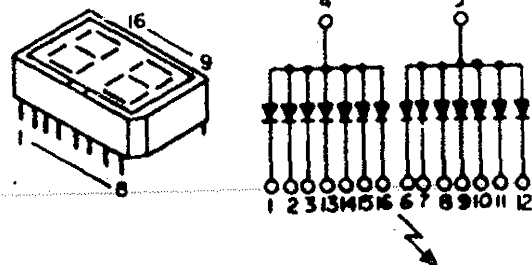

TLRG101

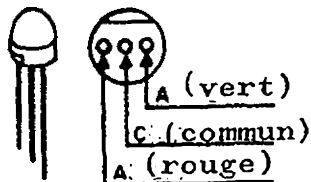

TLG124A
TLR124



SYNOPTIQUE CIRCUITS INTEGRES

uPD2816C

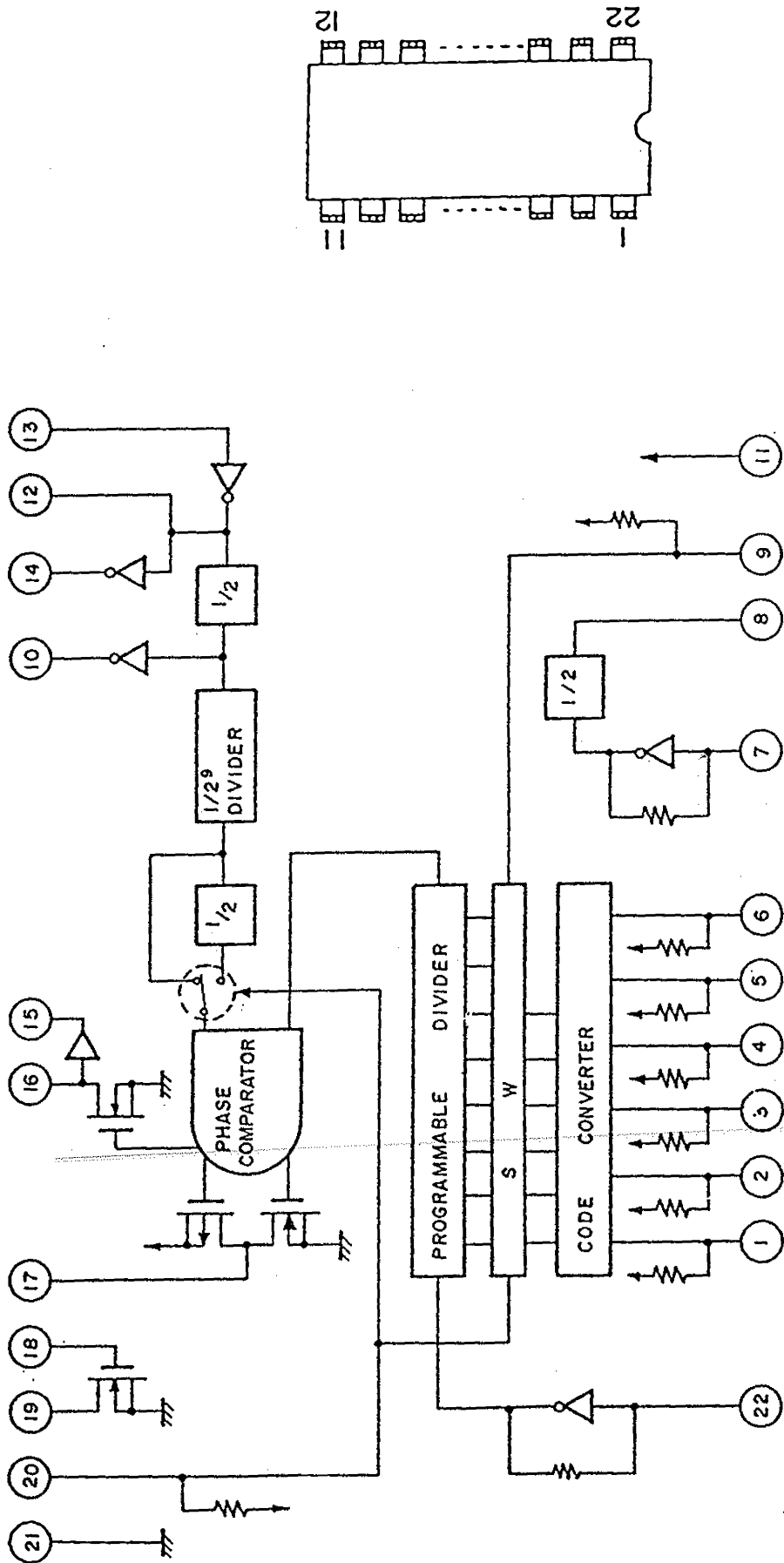

MARKING SIDE

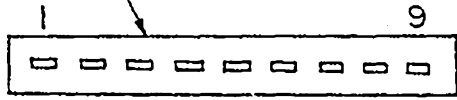

TA7310P-U

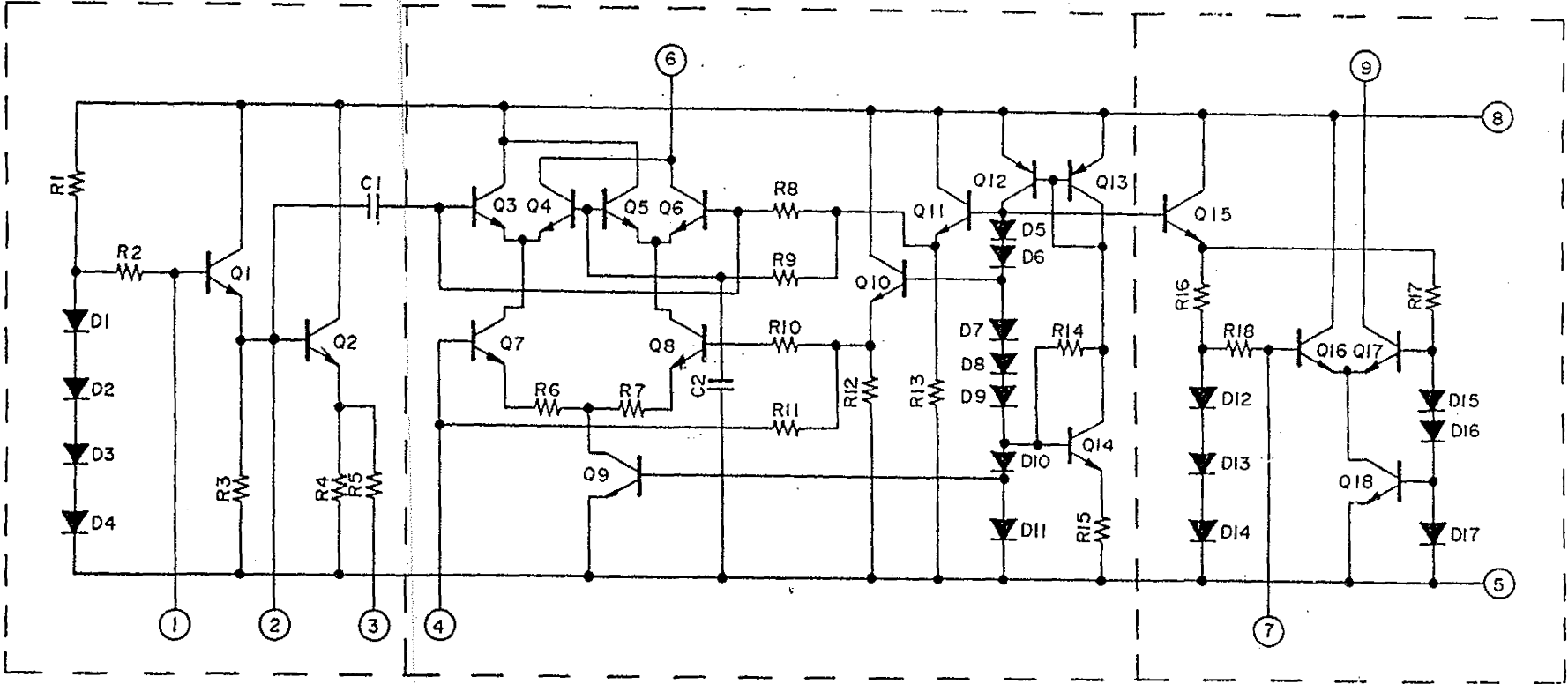

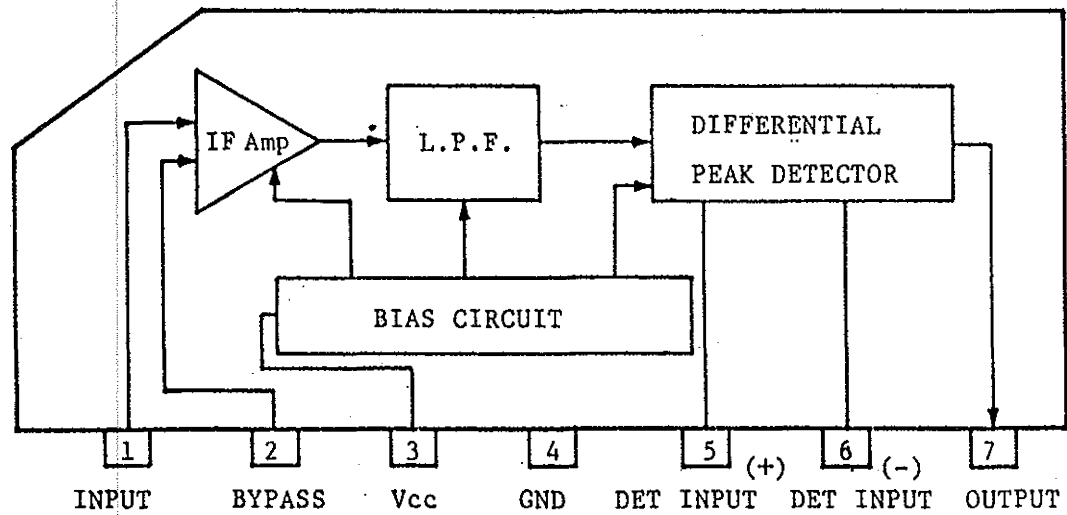

uPC1028H

MB3712

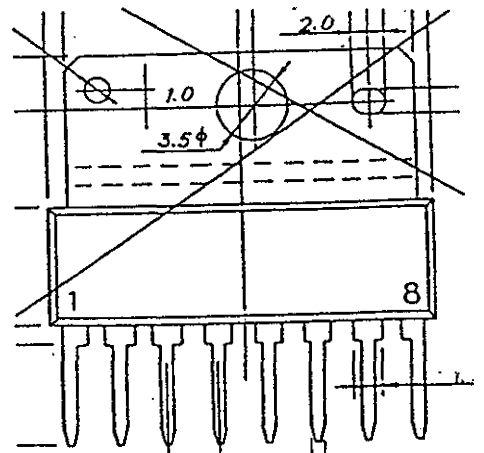
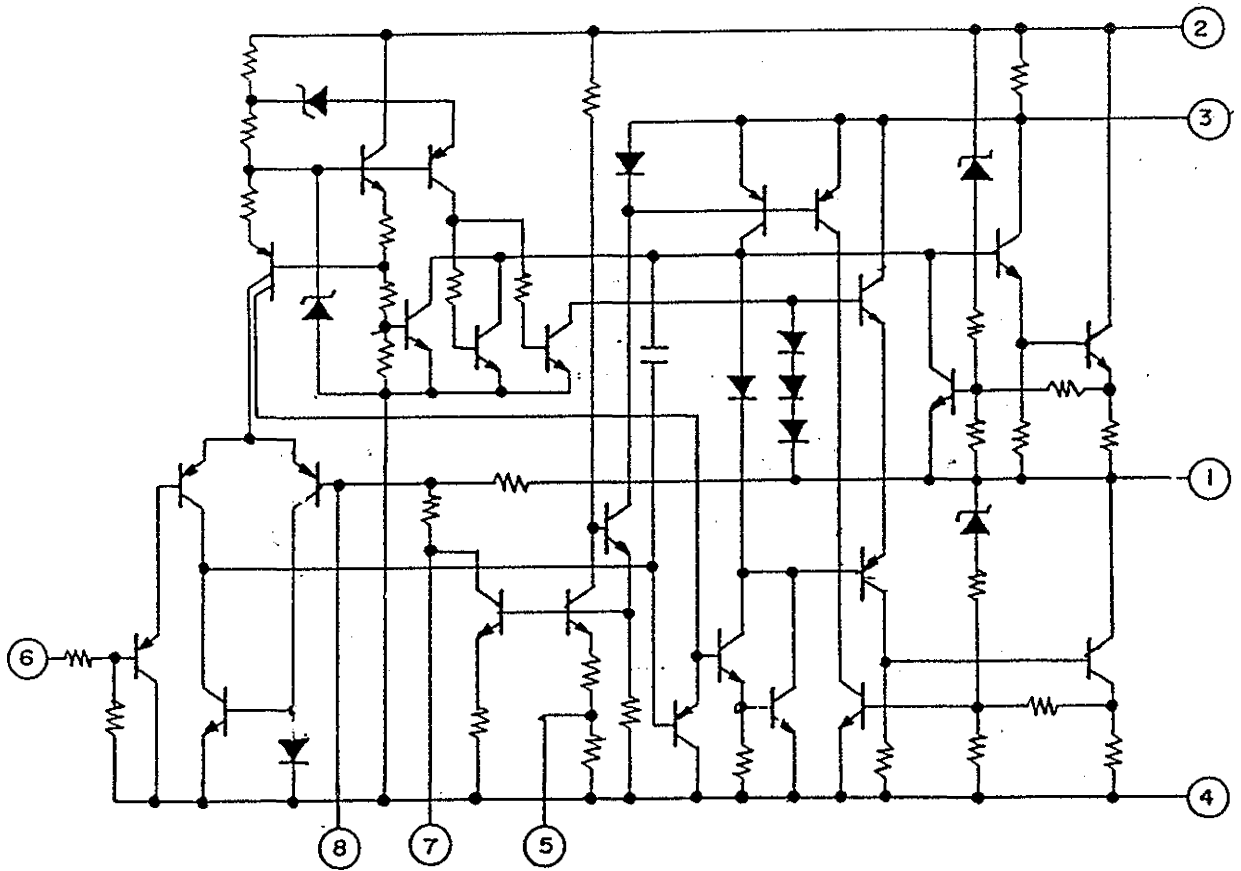

PLATINES

AFFICHEUR

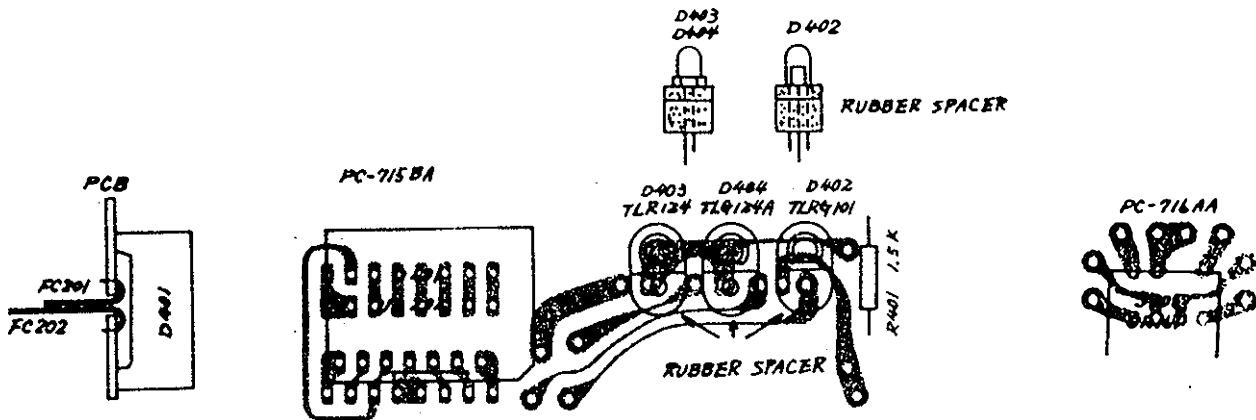

COMMUTATEUR DE CANAUX

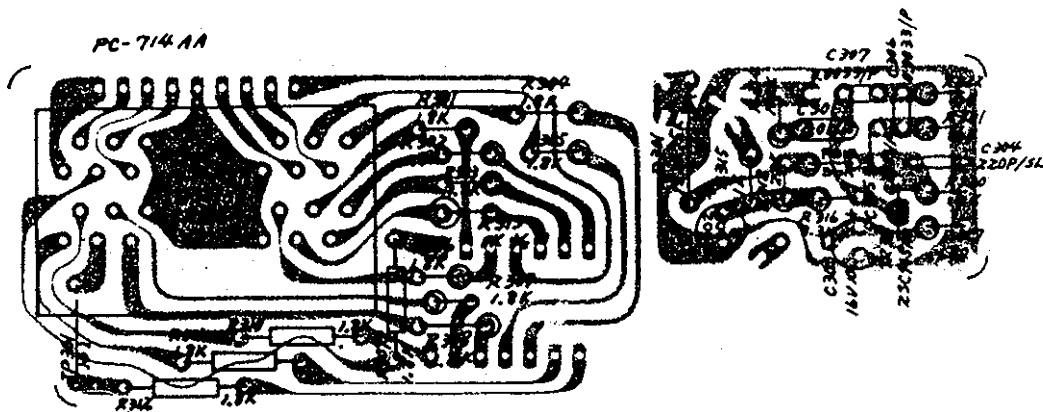

FM/AM ROGER BEEP

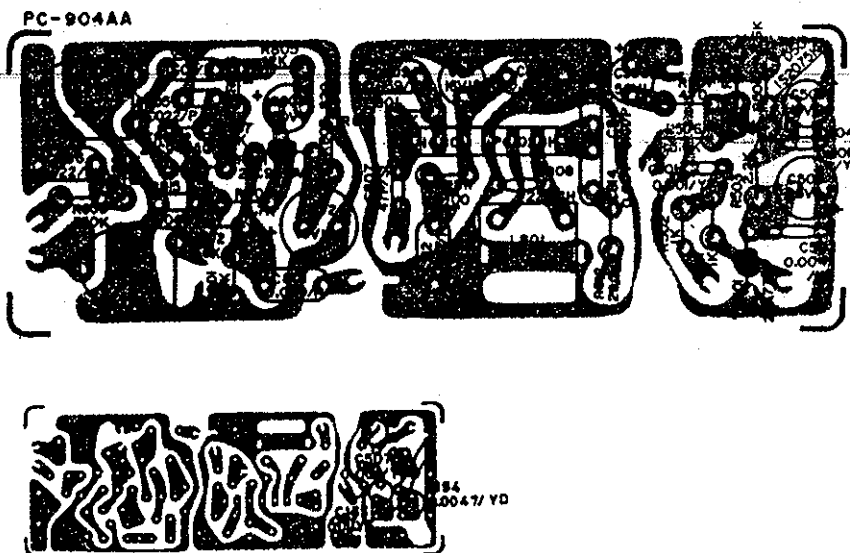



PC-713AD

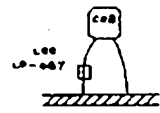
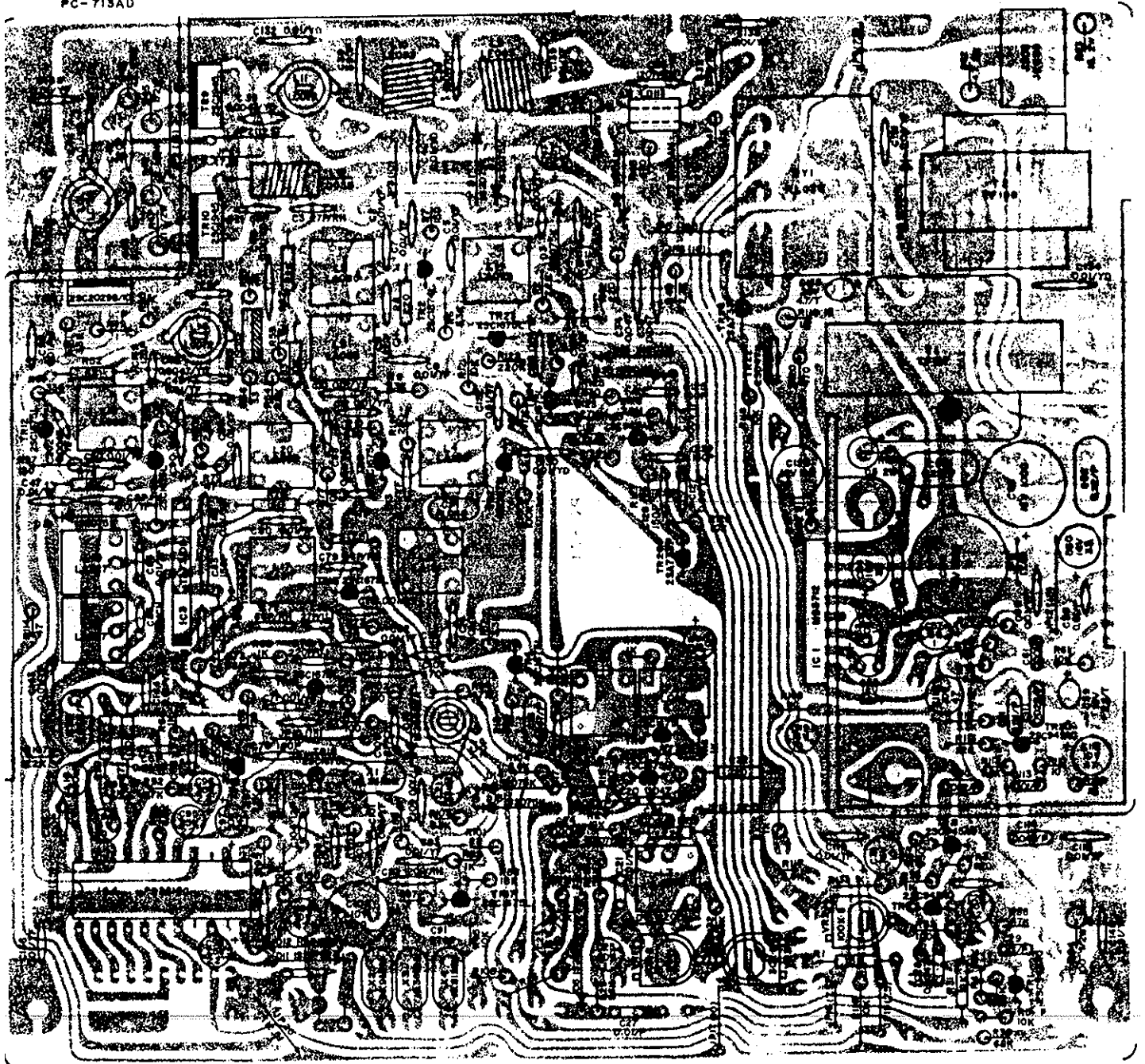

PC-713AD

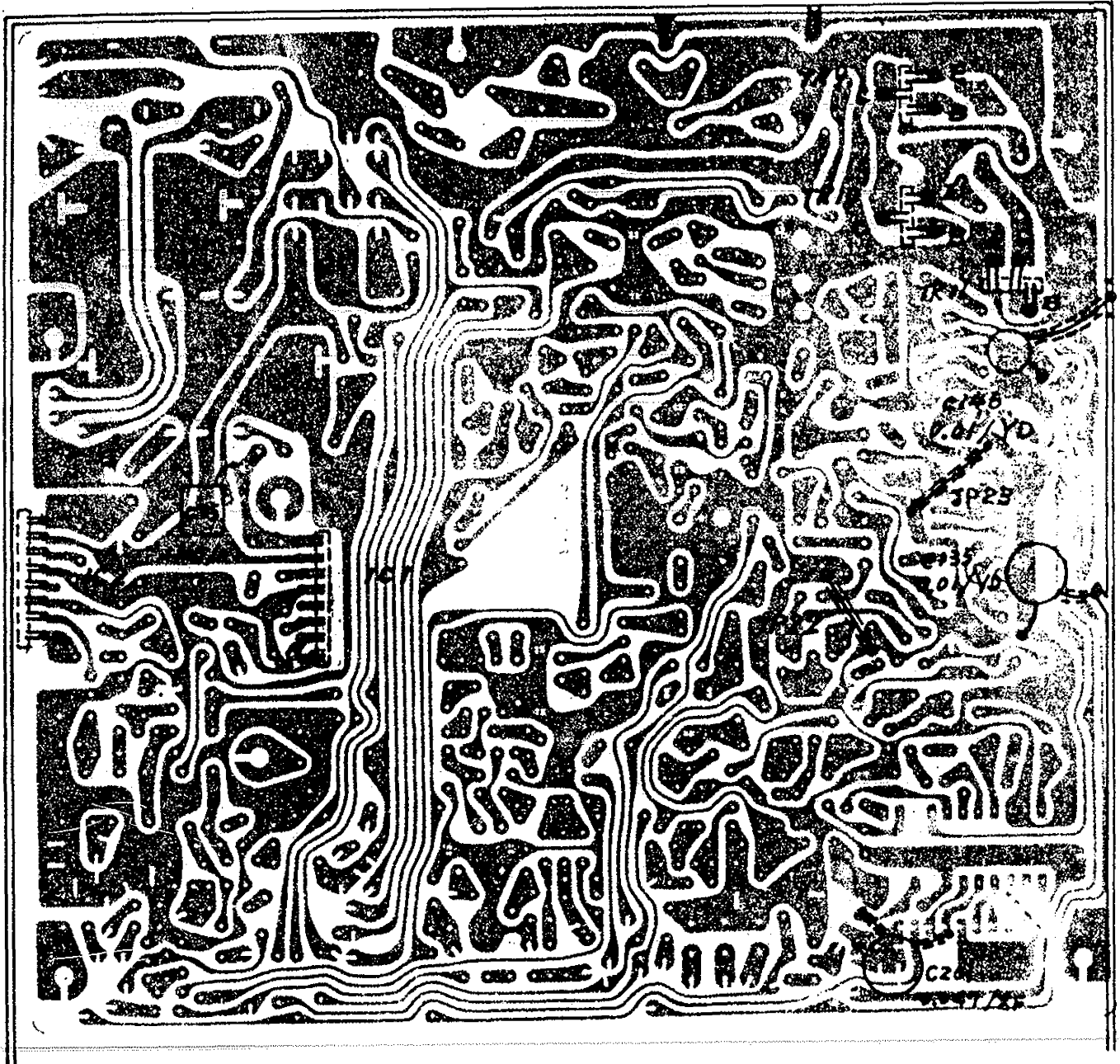

LISTE PIECES DETACHEES J.F.K.

LISTE PIECES DETACHEES J.F.K.

1

CODE	DESIGNATION	QTE/MOD.	CODE	DESIGNATION	QTE/MOD.
BC003	BOBINE LD-087	1	DV006	DIODE VARI-CAP 1S2688EA	2
BC009	SELF LZ-016 100UH	1	HM001	MICROPHONE MK-221	1
BC013	BOBINE LD-033	1	HP004	HAUT-PARLEUR SP-052	1
BC017	BOBINE LC-072	2	IP003	CIRCUIT INTEGRE MB3712	2
BC023	BOBINE LE-093	1	IR004	CIRCUIT INTEGRE UPC1028H	1
BC029	BOBINE LC-134	1	IR009	CIRCUIT INTEGRE TA7310P-U	1
BC030	BOBINE LD-113	1	IS005	CIRCUIT INTEGRE UPD2816C	1
BC031	BOBINE LE-092	1	JX001	JACK JK-089	1
BC038	SELF LZ-016 33UH	1	JX002	JACK JK-052	1
BR001	BOBINE LA-029	1	JX003	JACK JK-048	1
BR034	BOBINE LA-088	3	JX005	JACK JK-087	1
BR036	BOBINE LA-163	1	DA001	AFFICHEUR UR-202D	1
BR047	BOBINE LB-276	1	DX001	LED TLR-124 RED	1
BR053	BOBINE LA-180	1	DX002	DIODE / LED TLG-124A GREEN	1
BR054	BOBINE LA-181	1	PF001	FILTRE FL-048 SFE10.7MS2-M	1
BR055	BOBINE LA-204	1	PF002	FILTRE FL-066	1
BR057	BOBINE LA-311	1	PQ005	QUARTZ 10.240 QX-074	1
BR058	BOBINE LA-327	2	PQ009	QUARTZ 15.360	1
BR062	BOBINE LA-080	1	PQ010	QUARTZ 14.910	1
BT003	TRANSFORMATEUR TF-197	1	PQ011	QUARTZ 15.810	1
DC001	DIODE 1N60 AM	4	RV007	POTENTIOMETRE RV-329 50KB.50KA	1
DC003	DIODE ZENER XZ-051	1	RV018	POTENTIOMETRE RV-286 20KB 100K	1
DC005	DIODE 1S2075K	11	RV019	POTENTIOMETRE RV-330 1KB 5KA	1
DC008	DIODE 1N4003	1	RV020	POTENTIOMETRE RV-354 5KB	1
DC018	DIODE TLRG-101	1	SS007	COMMUTATEUR SR-216	1
DC019	DIODE ZENER XZ-094	1	SX020	RELAIS RL-036	1

CODE	DESIGNATION	QTE/MOD.
SX021	FUSIBLE FS-014 4A	1
SX022	COMMUTATEUR SR-161	1
SX023	COMMUTATEUR SW-245	1
SX024	COMMUTATEUR SW-246	3
TB005	TRANSISTOR 2SC1957-Q	1
TH006	TRANSISTOR 2SC1944-C	2
TH007	TRANSISTOR 2SC2029-A/10	1
TX001	TRANSISTOR 2SA733-P	3
TX002	TRANSISTOR 2SC945A-Q	9
TX003	TRANSISTOR 2SC1674-L	1
TX004	TRANSISTOR 2SC1675-L	13
TX008	TRANSISTOR 2SD471-L	1
VH005	VU-METRE MT-186	1

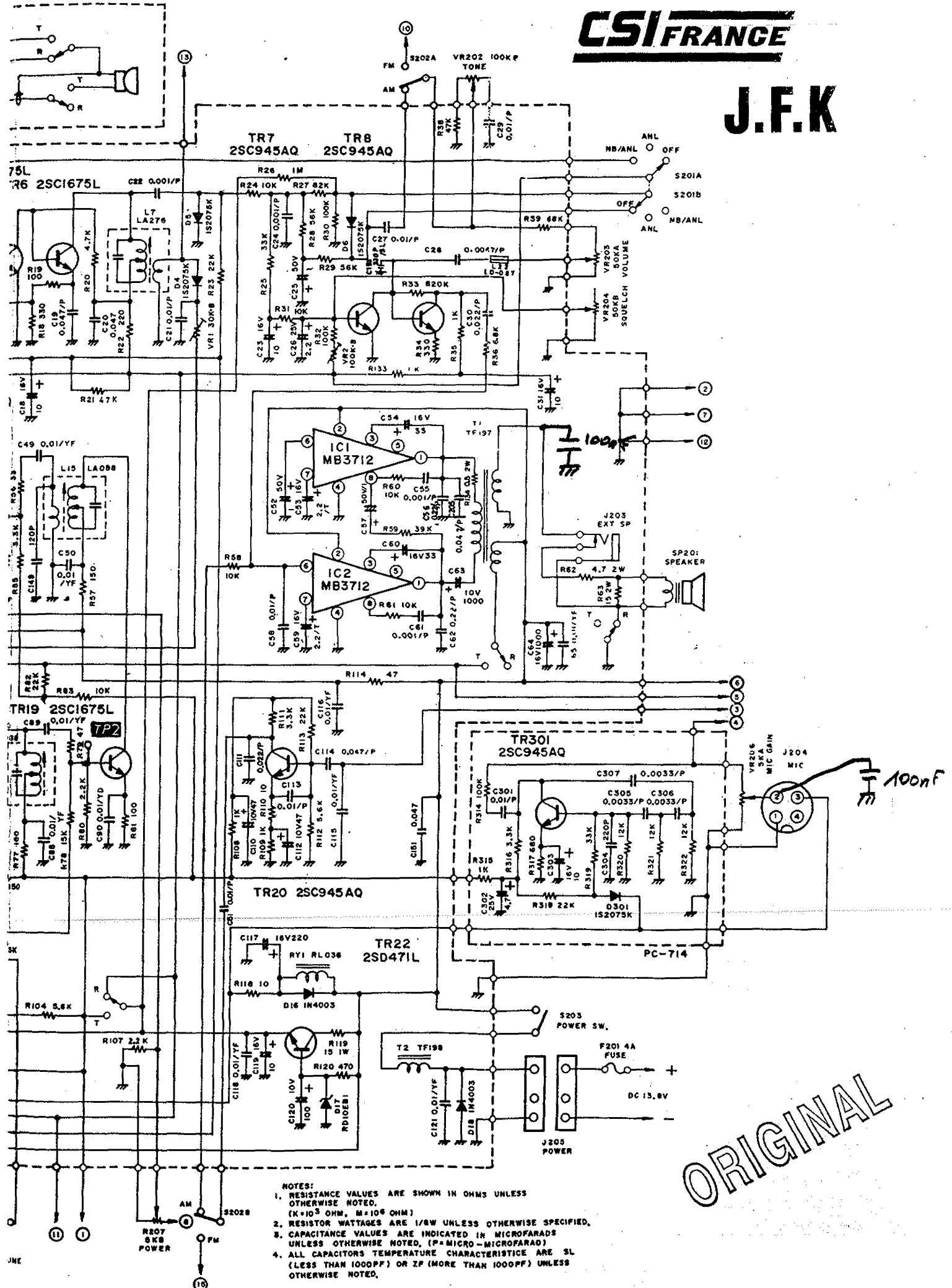

- NOTES:
1. RESISTANCE VALUES ARE SHOWN IN OHMS UNLESS OTHERWISE NOTED.
(K=10³ OHM, M=10⁶ OHM)
 2. RESISTOR WATTAGES ARE 1/8W UNLESS OTHERWISE SPECIFIED.
 3. CAPACITANCE VALUES ARE INDICATED IN MICROFARADS UNLESS OTHERWISE NOTED, (P=MICRO-MICROFARAD)
 4. ALL CAPACITORS TEMPERATURE CHARACTERISTIC ARE 5L (LESS THAN 1000PF) OR 2P (MORE THAN 1000PF) UNLESS OTHERWISE NOTED.

ORIGINAL

PC-713

TR23 2SC1675L TR24 2SC1675L TR25 2SC945AQ TR26 2SA733P TR27 2SC1675L

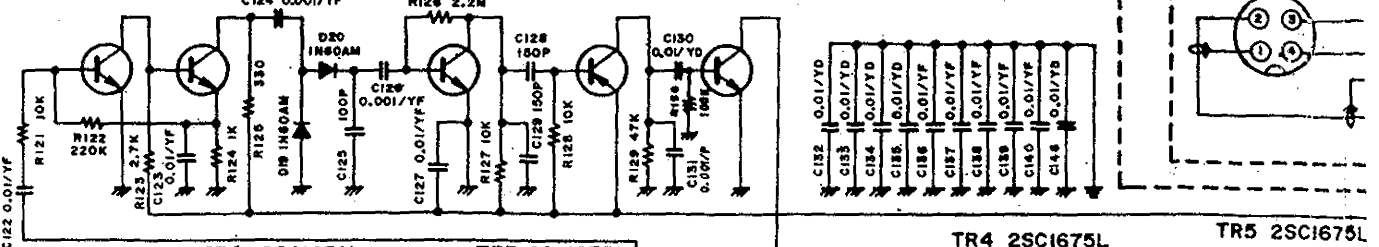

TR2 2SC1674L

TR3 2SC1675L

TR4 2SC1675L

TR5 2SC1675L

TR6

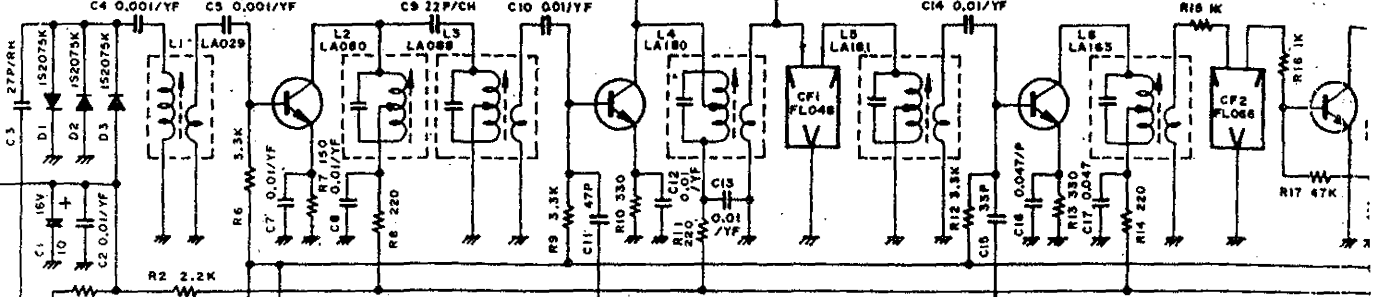

TR1 2SC945AQ

TR9 2SC1307(1)S

TR11 2SC2029B/10

TR13 2SC1975Q

TR12 2SC1675L

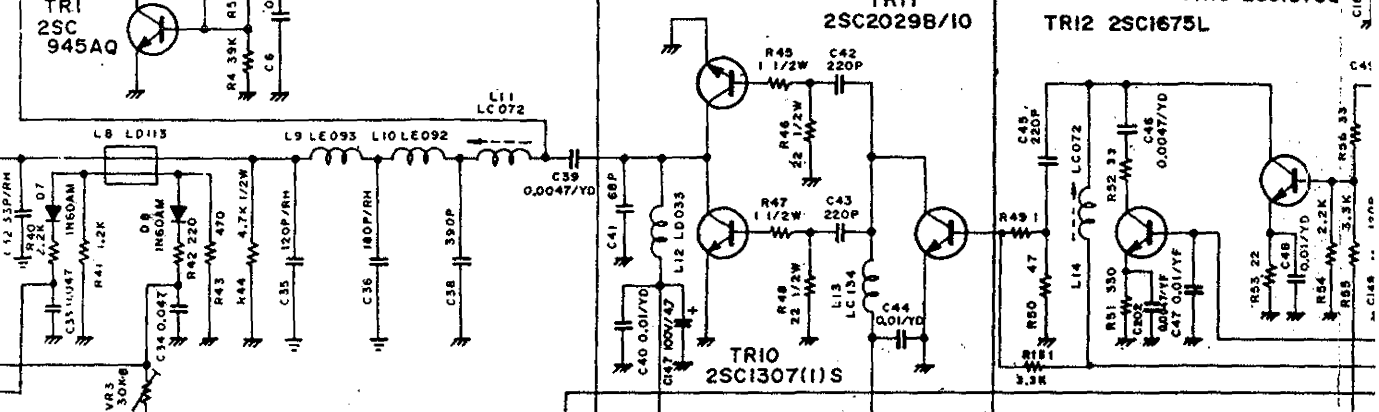

TR14 2SC1675L

TR15 2SC1675L

TR16 2SC1675L

IC3 TA7310P

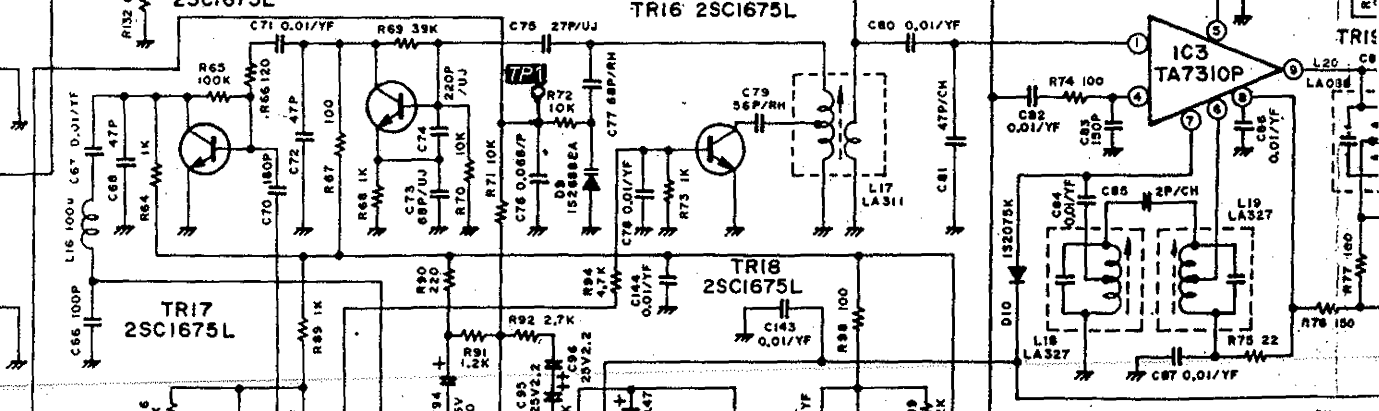

TR17 2SC1675L

TR18 2SC1675L

IC4 uPD2816C

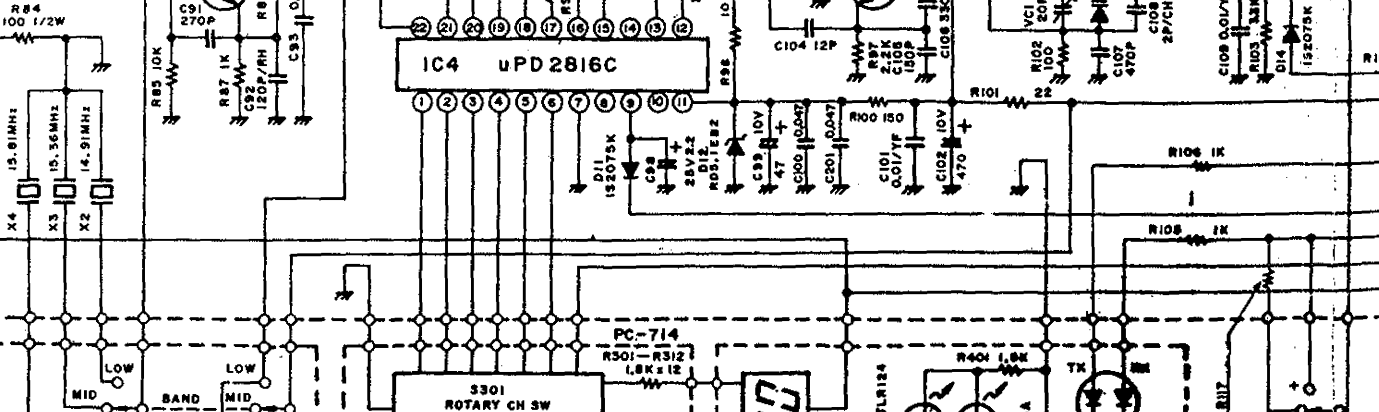

PC-716

PC-714

PC-715

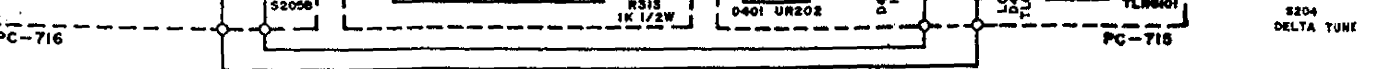

Q TR26 2SA733P TR27 2SC1675L

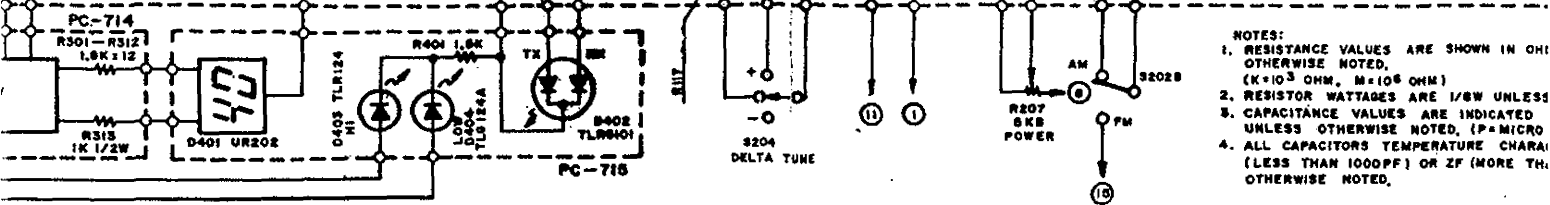
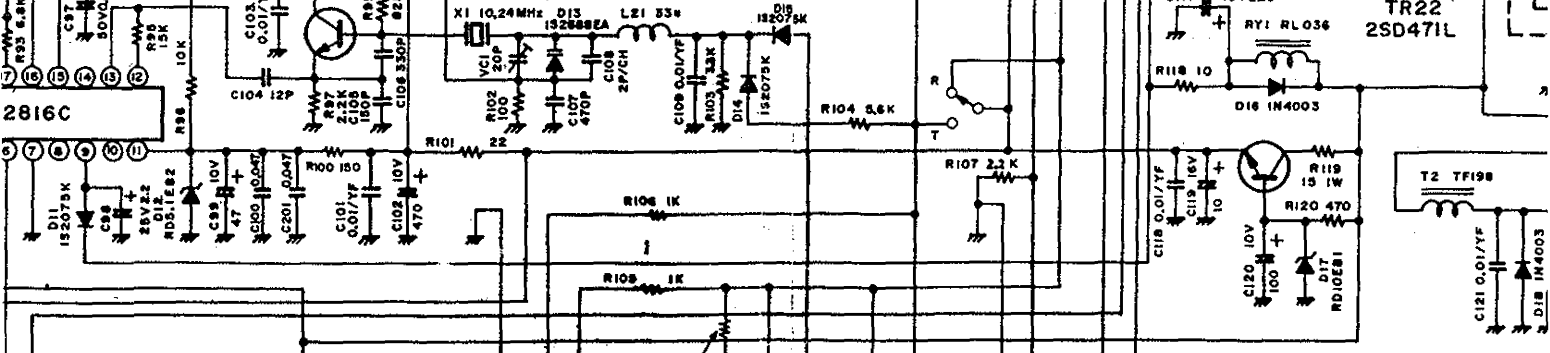
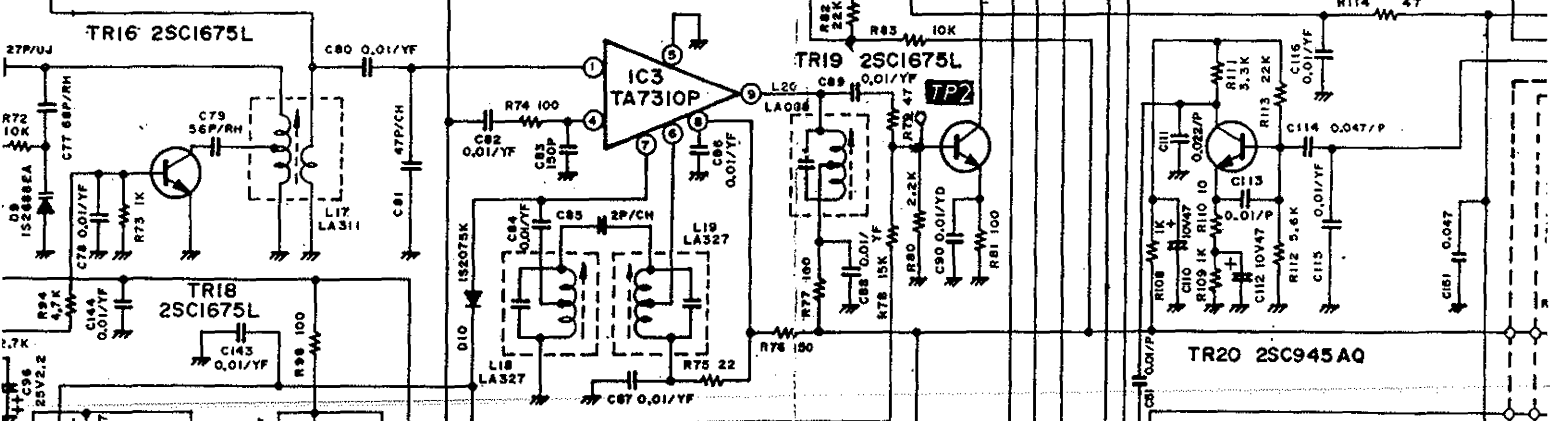
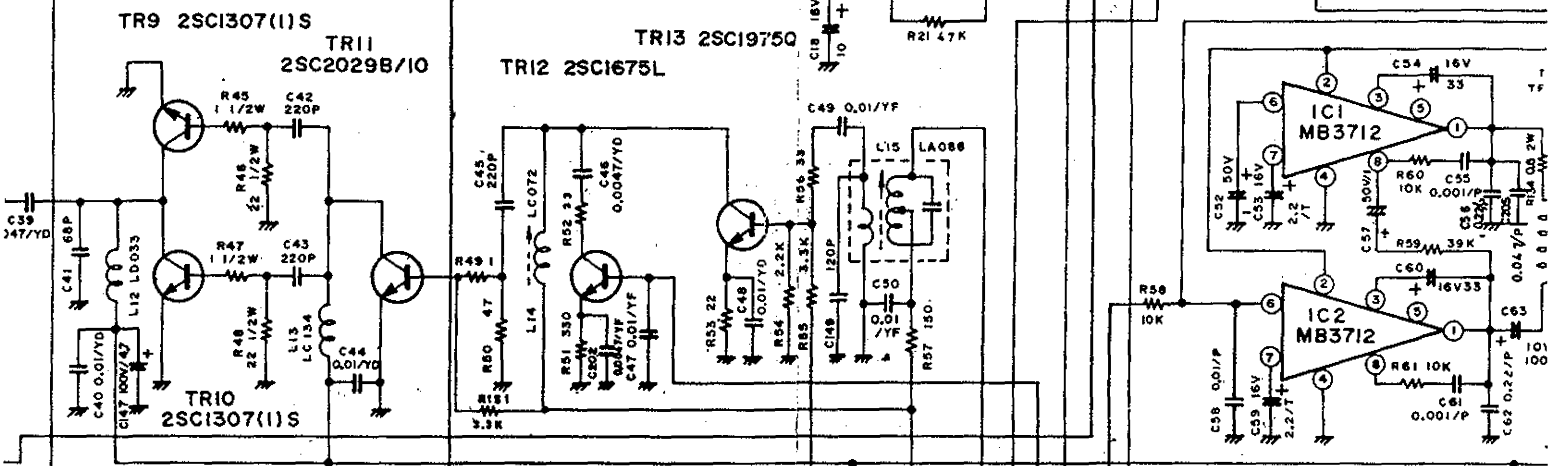
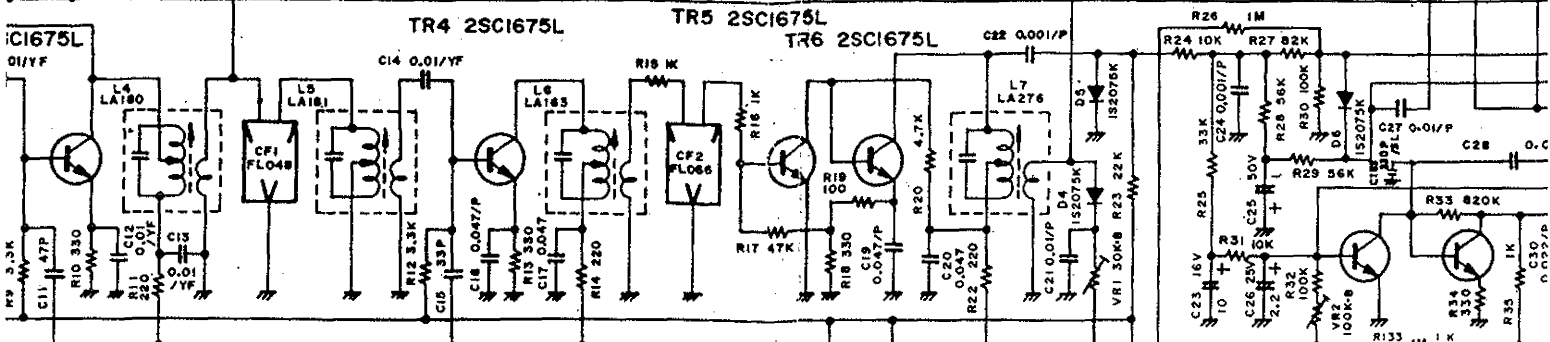
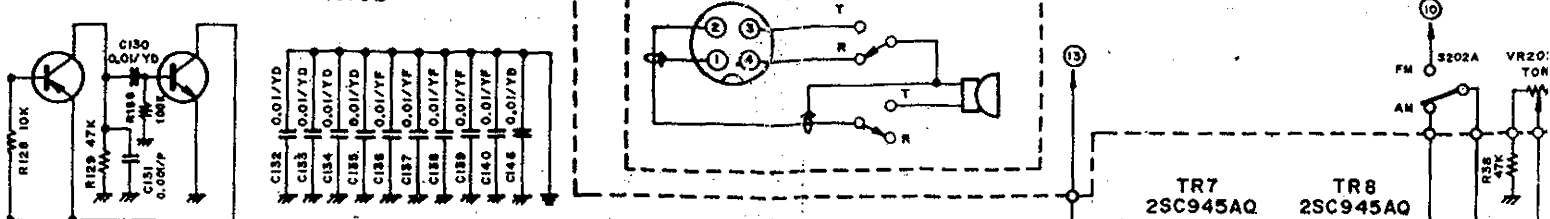

NOTES:
 1. RESISTANCE VALUES ARE SHOWN IN OHM UNLESS OTHERWISE NOTED, (K=10³ OHM, M=10⁶ OHM)
 2. RESISTOR WATTAGE VALUES ARE 1/8W UNLESS OTHERWISE NOTED.
 3. CAPACITANCE VALUES ARE INDICATED UNLESS OTHERWISE NOTED, (P=MICRO, Z=PIEZO)
 4. ALL CAPACITORS TEMPERATURE CHARACTERISTICS ARE INDICATED UNLESS OTHERWISE NOTED.

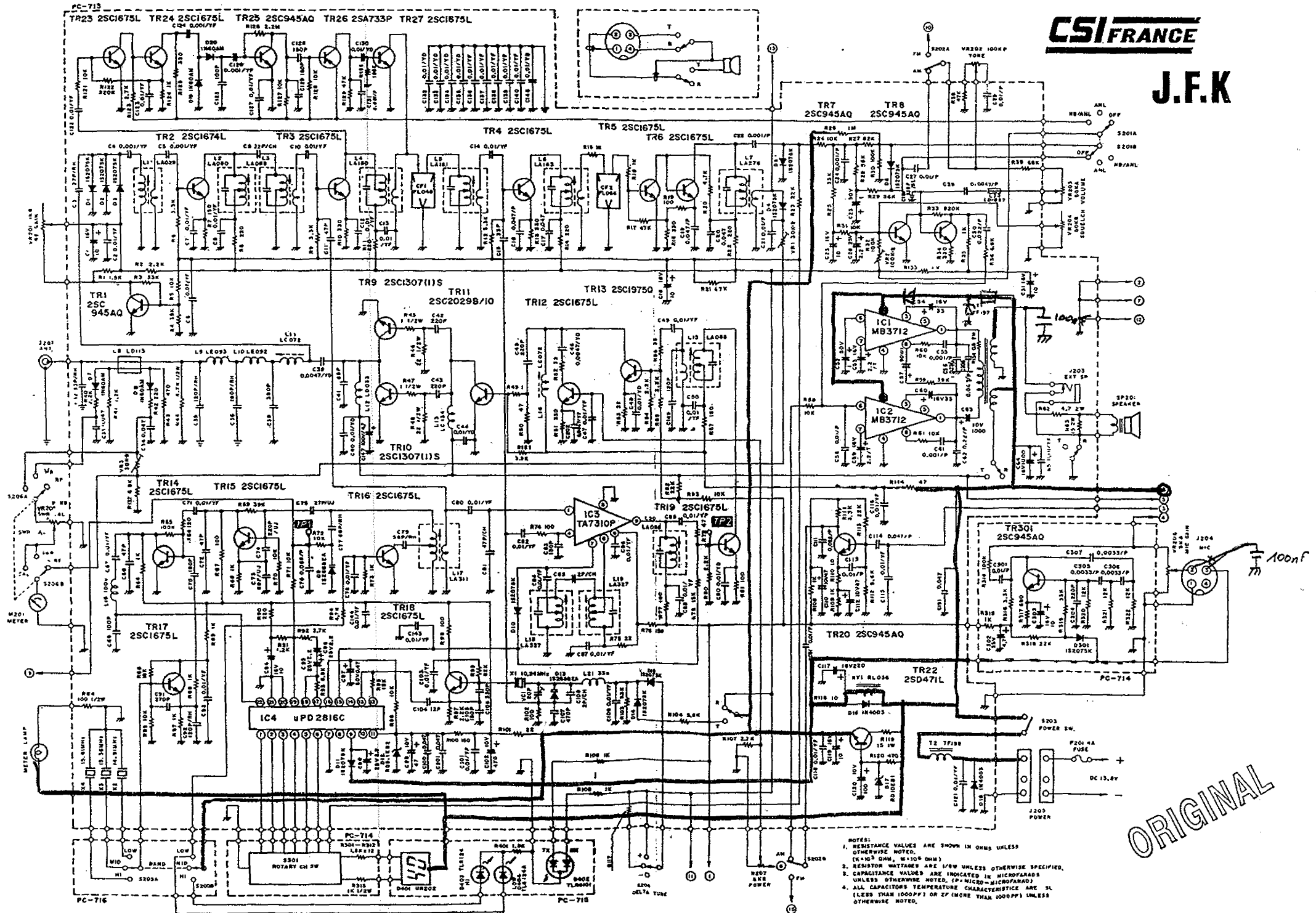

NOTES:
 1. RESISTANCE VALUES ARE SHOWN IN OHMS UNLESS OTHERWISE NOTED.
 2. RESISTOR VALUES ARE 1/4W UNLESS OTHERWISE SPECIFIED.
 3. CAPACITANCE VALUES ARE INDICATED IN MICROFARADS UNLESS OTHERWISE NOTED. (P= MICRO-MICROFARAD)
 4. ALL CAPACITORS TEMPERATURE CHARACTERISTIC ARE 5% (LESS THAN 1000PF) OR 2% (MORE THAN 1000PF) UNLESS OTHERWISE NOTED.

ORIGINAL

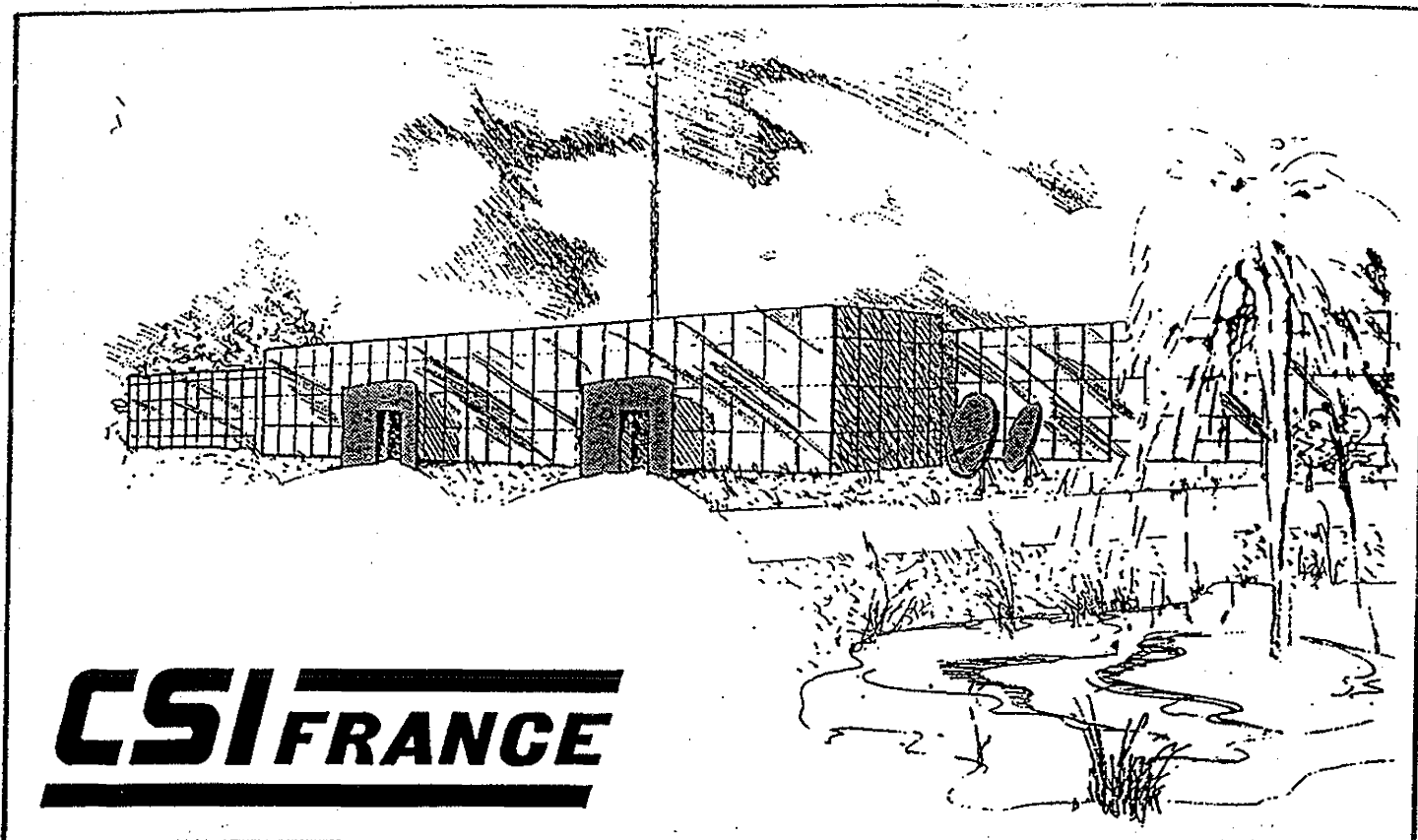

CSI FRANCE

SIEGE SOCIAL
 Route de SETE - BP 100
 34540 BALARUC Tél: 67.46.27.27
 Téléx: 490534F Fax: 67.48.48.49

SUCCURSALE «ILE DE FRANCE»
 5, rue des Pyrénées - BP 518
 94623 RUNGIS - Tél: (1)46.87.31.82
 Téléx: 205116F - Fax: 1)46.87.73.26

SUCCURSALE «RHONE ALPES»
 1, rue des Vergers 69760 LIMONEST
 Tél: 78.43.22.80 - Fax: 78.43.22.71

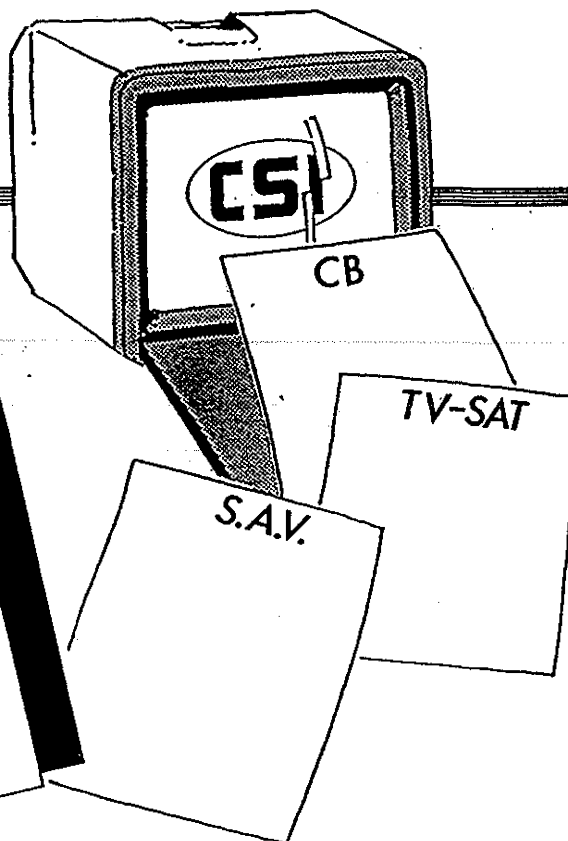

SUR MINITEL EN 36 16, TAPEZ CSIPLUS

ACCES GRAND PUBLIC
LE COMMERCIAL
LES PRODUITS
 — ensemble de notre gamme TX, Antennes, TV-SAT

ACCES AUX PROFESSIONNELS
 (utilisation d'un code personnel)

LE TECHNIQUE
 — le système de DIAGNOSTIQUE (radiotéléphonie)
 — la détection des PANNES (radiotéléphonie)
 — ALIGNEMENT des TX
 — listing des PIECES DETACHEES (en cours)