

Section 1 Specification

Thank you for your confidence in selection Our two-way radio equipment. We know you'll find your transceiver as exciting as it is practical. Many years of valuable experience designing electronic products are behind our two-way communications systems. Only the highest quality components are incorporated into SSB radios to assure assure reliability and maximum performance.

Installing and operating the SSB is not complicated, but the flexibility provided by its numerous operating features may not be fully appreciated until a little time is spent becoming familiar with its controls and connections. It will be to your advantage to save all the packing materials -cartons, fillers, cushioning, etc., they will prove valuable in preventing damage should you ever have occasion to transport or ship the SSB.

Specifications

General

Channels	3000 channels
Modulation Modes	CW, FM, AM, USB, LSB
Frequency Range	26.065 to 28.305 MHz
Frequency Control	Phase-locked synthesizer
Frequency Tolerance	±0.005%
Frequency Stability	±0.003%
Operating Temperature Range	-30°C to +50°C
Microphone	Plug-in (4-pin), 600 Ohm dynamic type
AC Input Voltage	110V 5CHz (220V 60Hz)
AC Power Consumption	75W
Antenna Connectors (A and B)	Standard SO-239 type X2
Semiconductors	6 IC, 1 FETs, 43 Transistors
Meter #1	Indicates relative RF power output/antenna SWR
Meter #2	Indicates received signal strength
Transmitter Power Output	Low 0.5-AM 0.5-FM 3-SSB(W) Normal 5-AM 5-FM 12-SSB(W)
SSB Generation	Dual-balanced modulation
AM Modulation	Class B amplitude, collectors modulation
AM Modulation Capability	Up to 100%
FM Deviation	+1.5 KHz @ 1,250 Hz 20 mV audio
Clarifier Range	±5 KHz
Harmonic and Spurious Emission	Better than 60 dB
AM/FM Frequency Response	400 to 5,000 Hz
SSB Frequency Response	400 to 3,000 Hz
Output Impedance (A and B)	50 Ohms unbalanced X2
Output Indicators	RF Meter shows relative RF output power.

Receiver

AM Sensitivity	1 μV for 10 dB S/N
FM Sensitivity	1 μV for 20 dB S/N
SSB Sensitivity	0.2 μV for 10 dB S/N
AM/FM Selectivity	5 dB at 4 kHz, 50 dB at 10 kHz
SSB Selectivity	5 dB at 2 kHz
Image Rejection	More than 50 dB
IF Rejection	More than 80 dB at 455 kHz
AGC	Change in audio output less than 12 dB: from 10μV to 0.4V
Squelch	Adjustable threshold less than 0.7 μV
Audio Frequency Response	400 to 2,500 Hz
Distortion	Less than 10% at 2 watts output into 8 Ohms
Adjacent Channel Rejection	>75 dB
Cross Modulation Intermediate Frequency	>50 dB
Clarifier Range	10.695 MHz (Am-1st, SSB), 455 KHz (AM-2nd)
Noise blanker	=5 KHz
Audio Output Power	!F single gate type
Built-in Speaker	More than 3 watts into 8 Ohms
External Speaker (optional)	8 Ohms, dynamic Disables internal speaker when connected

Section 2 Installation

Location/Connection

The transceiver should be placed in a convenient operating location close to an AC power outlet and the antenna lead-in cable (s).

The transceiver is attached with the AC power cord set. Proceed as follows to complete all necessary connections to the transceiver.

1) Your transceiver has two standard antenna connectors of type SO-239 both located on rear panel, for easy connection to standard PL-259 coax plugs. If the coax antenna cable must be made longer, use coax cable with impedance of 50 ohms, frequency ratings for 27 MHz, and use only enough cable to suit your needs. This will insure a proper impedance match and maximum power transfer from the transmitter to the antenna.

2) **AC Power Operation** : Use 110 (220) volts AC power for the base station.

Noise Interference

There are several kinds of noise interfering you may encounter in base station operation. Some of these noise sources are; fluorescent buzz, nearby commercial broadcast, electrical appliance, lawnmower, and electrical storms, etc. Commercial products are available to reduce interference from these sources. Consult your dealer or CB/ amateur radio supply shops.

Antennas

For best transmission and reception, your CB transceiver should use an antenna especially designed for a frequency of 27 MHz. Antennas are purchased separately and include installation instructions. Numerous types of CB antennas are available that range from emphasis on ease of installation to emphasis on performance. Often the difference in performance between many of the antenna is modest. You can connect 2 antennas to your CB, or 1 antenna and 1 dummy load.

1) Vertical Ground Plane Antennas.

These are omnidirectional antennas that provide optimum performance for contacting other fixed stations using vertical type antennas in addition to all mobile stations. For medium long range communications work.

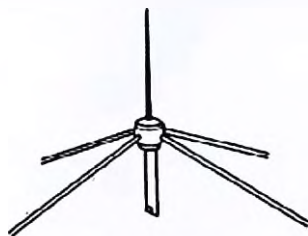

Ground Plane

2) Directional Beam Antennas.

Highly efficient and directional antennas generally intended for fixed-to-fixed very long range communications.

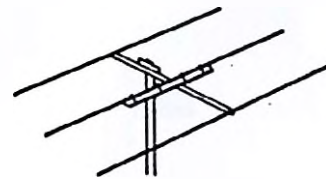

Directional Beam
Antenna

Remote Speaker

The external speaker jack (EXT. SP) on the rear panel is used for remote receiver monitoring. The external speaker should have 8 ohms impedance and be able to handle at least 3 watts. When the external speaker is plugged in, the internal speaker is disconnected.

Note. The PHONE jack on the front panel overrides both external and internal speakers. When the plug from a headphone is plugged to the PHONE jack, both internal and external speakers are silenced simultaneously.

Public Address

An external 8 ohm, 3 watt speaker must be connected to the PA jack located on the rear panel when the transceiver is used as a public address system. The speaker should be directed away from the microphone to prevent acoustic feedback. Physical separation or isolation of the microphone and speaker is important when operating the PA at high output levels.

Section 3 Operation

Controls/Indicators

There are 17 controls and 10 indicators on the front panel of your SSB.

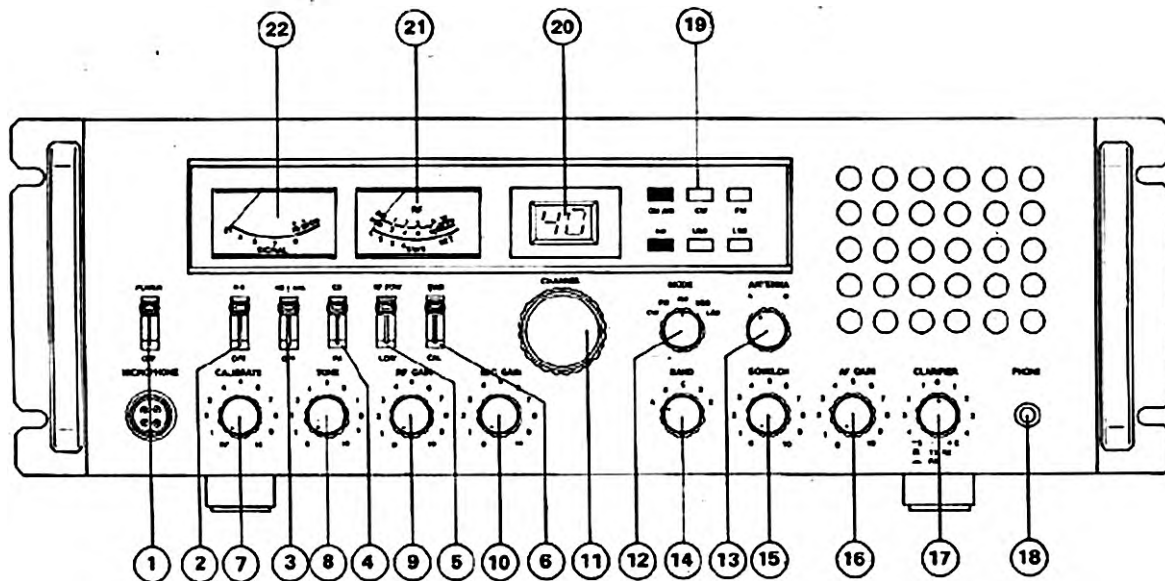

Control Functions

1 Power/On-off

Place in Power (lever up) position to apply power to the unit.

2 RB Switch

This switch activates the ROGER BEEP circuit when placed in RB (lever up) position.

3 NB + ANL Switch

This switch activates the noise blanker circuit and the automatic noise limiter in the audio when placed in NB - ANL (lever up) position.

4 CB-PA Switch

This switch selects the public address mode of the transceiver. The PA function should not be used unless an external speaker is connected to the PA SP jack on the rear panel. See the Public Address Operation on page 6.

5 RF Power Select Switch

During AM or FM operation, with this switch placed in the RF Power position, the transceiver will produce full rated transmit power for long range communication. The Low position will produce lower transmit power for shorter range communication.

6 SWR-Calibrate Switch

This switch changes the SWR meter function in two ways:

- CALIB (lever down): Used to calibrate the SWR Meter before measuring your antenna SWR ratio.
- SWR (lever up): Used to directly read the SWR of antenna connected to the unit. See Accessory Circuit Operation.

7 Calibrate Control

This control is used for calibrating the SWR meter for accurate SWR readout in conjunction with the SWR-CALIB Switch.

Note: So that the meter functions as RF power meter, be sure to set this control to fully counterclockwise position marker RF.

8 Tone Control

This changes tonal sound quality when receiving. Clockwise rotation will emphasize the high tone.

9 RF Gain

This control is used primarily to optimize the reception in strong signal areas. Under normal operating conditions the control should be turned fully clockwise. When strong overloading or distorted signals are received rotate this control counterclockwise to reduce gain.

Note: The Squelch Control (15) may require readjustment with reduced RF Gain control.

10 Microphone Gain

A preamplifier circuit is built into this unit to increase microphone gain. Experiment with this control for the setting that will best suit your individual use.

11 Channel Selector

Has 40 detents in a turn and selects one of the channels desired. Use the Channel selector in conjunction with the Band Select switch. The selected channel is digitally displayed in the window above the selector.

12 Mode Selector

Selects the mode of operation in either CW, standard FM, AM or USB and LSB. Transmissions in any mode can only be communicated to stations operating in the same mode.

13 RF POWER Switch HI-MID-LO

Set this switch to the position that selects the RF power output you want in AM or FM transmission.

14 Band Select Switch

Used with the channel selector. Selects one of 5 bands of 40 frequencies. See back cover to page 11 for information of channel provision and frequencies.

15 Squelch

This control is used to cut off or eliminate receiver background noise in the absence of an incoming signal. For maximum receiver sensitivity it is desired that the control be adjusted only to the point where the receiver background noise or ambient background noise is eliminated. Turn fully counterclockwise then slowly clockwise until the receiver noise just disappears. Any signal to be received must now be slightly stronger than the average received noise. Further clockwise rotation will increase the threshold level which a signal must overcome in order to be heard. Only strong signals will be heard at a maximum clockwise setting.

16 AF Gain

Permits you to adjust the listening level when receiving.

17 VFO

Operates on both TX and RX modes ($\pm 5\text{kHz}$), allowing you to use the inter-channel space. Especially useful in SSB.

18 Phone Jack

Accepts a plug from a headset of 4 to 32 Ohm impedance. Insertion of the plug will silence the built in speaker (and external speaker connected to External Speaker jack).

19 Function Indicators

LED indicators located in the LED area permit you to know instantly the mode to which the unit is engaged. On Air: Lights up during transmit mode indicating you are on-the-air.

CW-FM-AM-USB-LSB: Indicates a corresponding mode selected by the Mode selector 12).

20 Channel Readout

This is the LED (light emitting diode) digital readout to indicate the channel selected by the Channel selector.

21 Power/SWR Meter

Used for two purpose - to indicate relative transmitter power when transmitting and to indicate antenna SWR (standing wave ratio). Note that the power meter has separate scales for AM (FM) and SSB (CW) transmission, respectively.

22 S [Signal] Meter

The left hand meter provides a relative indication of the signal strength of a received signal in S units during reception. Note that SSB signals will respond this meter only during voice modulation. This being due to the fact that SSB transmissions do not contain a continuous RF carrier as is found on AM or FM and CW.

23 Push-to-Talk Microphone

The receiver and transmitter are controlled by the Push-to-Talk switch on the microphone. Press the switch and the transmitter is activated; release the switch to receive. When transmitting, hold the microphone two inches from the mouth and speak clearly in a normal voice. The radio comes complete with the low impedance dynamic microphone (supplied). Note: Depressing the Push-to-Talk switch on the microphone is also required to activate the PA system.

Rear Panel

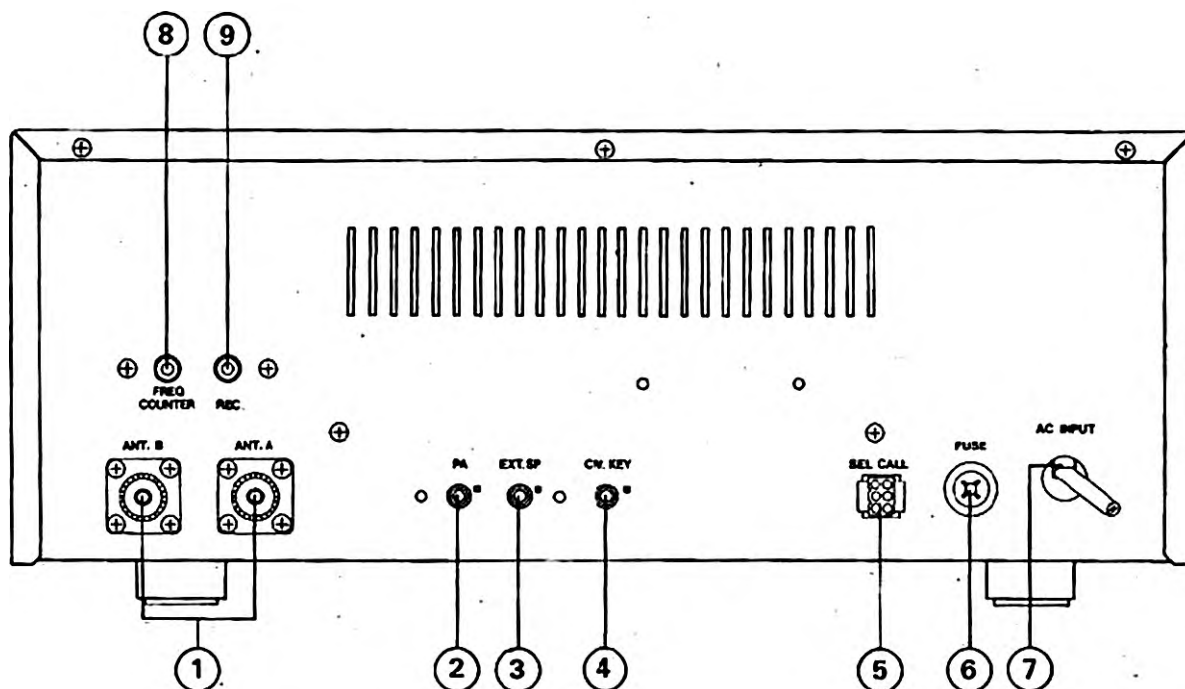

Rear Panel Connectors

1 Antenna Receptacle A/B

Accept PL-259 type coaxial plugs from antenna system. Switching to connect the transceiver output to either receptacle is done with the Antenna A-B switch on the front panel.

2 PA Speaker Jack

Used for public address operation. The PA speaker should be connected to this jack using 1/8" (3.6mm) diameter plug. Insertion of an external speaker into the External Speaker jack will not interrupt the PA operation.

3 External Speaker Jack

Used to connect an external speaker for extra sound source. Use 1/8" (3.6mm) diameter plug for connection. Insertion of the plug into this jack will silence the internal speaker.

4 CW Key

Use for morse code operation. Connect a CW key to this jack and place the CW/FM/AM/USB/LSB switch in the CW position.

5 Selective Call Jack

A provision has been made which enables your transceiver to couple with a selective call set (available from your dealer). This jack is used to connect the selective call set to the unit, and is normally occupied with a plug prewired for normal CB operation. Do not remove the plug unless you are using the jack. Following the dealer's advice and instruction manual accompanying the purchased selective call set will ensure proper selective call installation and operation.

6 Fuse

Accommodates a fuse for AC input circuit protection. Use 125V 2A or 250V 1A fuse for replacement.

Note. Before replacing the fuse, see your dealer to check to find out the reason why the fuse was blow. Replacing without check may only blow the fuse again.

7 AC Power Cord

Connects to AC power outlet for AC mains supply.

8 Frequency Counter Output Jack

The RCA-type (pin) jack is used to connect an optional frequency counter so that you can watch channel frequency digitally. The frequency counter readout will be possible on transmitting only.

9 Recording Output Jack

The RCA-type (pin) jack provides output for connection to a tape recorder to permit recording of received signals or your modulating voice.

Operating Procedure To Receive

IMPORTANT: Make sure that the antenna, power source, and microphone are connected before you operate.

- 1) Set the CB-PA switch to CB position.
 - 2) Turn the unit on by setting the Power Switch to On position. Now the meters, Channel Indicator, and Function Indicators will be illuminated.
 - 3) Temporarily, set the Mode Switch in AM position.
 - 4) Set the Squelch Control in fully counter-clockwise position and adjust the AF Gain control for a comfortable listening level.
 - 5) Listen to the background noise from the speaker. Turn the Squelch Control slowly clockwise until the noise just disappears (no signal should be present). Leave the Squelch Control at this setting. The Squelch Control is now properly adjusted. The receiver will remain quiet until a signal is actually received. Do not advance the Squelch Control too far clockwise or some of the weaker signals will not be heard.
 - 6) Depress the Clarifier and set it to the center (12 o'clock) position.
 - 7) Select a desired mode of operation, CW, FM, AM, USB or LSB and adjust the Clarifier.
 - 8) Select a channel you desire by the Band Select switch, then by the Channel Selector.
- Note. If you want to operate in between channels, pull out the clarifier knob and rotate it upscale or downscale. (This also affects in transmitting mode.)

Operating Procedure To Transmit

- 1) Select the desired channel and mode of transmission.
- 2) If the channel is clear, depress the Push-to-Talk switch on the microphone. Speak in a normal tone of voice. Standby-Beep

A special provision has been built in your radio to give other stations a sign which tells that you are turning to receive. Without needing switching operation to activate this feature, a beep tone is automatically transmitted at each time you release the push-to-talk switch on the microphone to turn to receive mode.

Microphone gain control

A preamplifier circuit is built into the radio to increase the microphone gain. Experiment with the control for setting that will best suit your individual use.

Note. When the microphone gain control is set to maximum, ambient noise may also be picked up by the microphone. In high noise situations, low microphone gain setting may produce the best results.

The microphone gain control is also used to adjust PA loudness.

Public Address Operation

To use this feature of the transceiver, a speaker having a voice coil impedance of 8 to 16 ohms and a power handling capability of at least 3 watts should be connected to the PA SP jack on the rear panel. Be sure that there is physical separation between the microphone and the PA speaker itself. If the PA speaker is located very close to the microphone, acoustic feedback will result when the PA amplifier is operated at high volume (or when PA is used indoors). Adjustment of PA volume is made with the MIC GAIN control.

SWR Measurement

Most antennas are factory tuned, but the antenna efficiency may be peaked by slightly adjusting the length of antenna using the SWR meter built into the unit. This adjustment may improve the antenna standing wave ratio (SWR). The SWR permits you to determine how well matched the antenna and its cables are to your transceiver.

- 1) Set the unit in the receive mode as instructed under the Operating Procedure to Receive section.
- 2) Set the Mode switch to AM position; the SWR-Cal 6) switch to the Cal position.
- 3) Press the Push-to-Talk switch on the microphone and turn the Calibrate Control clockwise (past click) so that the SWR meter pointer exactly coincides with the Set mark on the scale. Release the Push-to-Talk switch.
- 4) Set the SWR-Cal switch to the SWR position and depress the Push-to-Talk switch again. The SWR of your antenna is read directly on the scale.

Note: An SWR below 2 or less is desired as this indicates that over 95% of the transmitted power is broadcast into the air.

Section 4 Maintenance & Adjustment

Circuit Theory

The concept of PLL system frequency synthesization is not of recent development, however, it has not been a long age since the digital theory has been coupled with the PLL synthesization technology. Although details of the PLL theory is somewhat complicated and not within the scope of this brochure, we hereby provide the fundamental theory of it.

PLL Circuitry. PLL is an abbreviation of the phase-locked loop which is fundamental composed of a closed loop feedback circuit. The feedback component is the balance of frequency drifts and the PLL circuit acts to cancel it out. To detect out the frequency drift of the PLL output, a fixed reference oscillator (10 kHz, 1/1024 divided down from 10.240 MHz) is compared constantly with the input frequency (10 kHz). The input frequency is obtained by dividing the VCO frequency. A functional block diagram is provided below under 'PLL Circuit' for the easier understanding.

Off-Set frequency oscillator TR-29 The off-set-frequency oscillator TR-29 oscillates at 14.460 MHz for all band switching between these oscillating frequencies is made by biasing the diodes D 97 to D111.

The off-set frequency signal is obtained at TR-29 emitter and flows through L-16 and C-88 into TR-25 mixer where it is beat with the VCO signal. The VCO signal is obtained from the following:

$$f_{VCO} = f_{\text{off-set}} + N f_r$$

Where, f_{VCO} = VCO frequency, N = programming code for divider output, f_r = reference frequency step, 0.01 MHz.

i.e. At channel #1 in band A, and AM band corresponding N code is 91.

$$f_{VCO} = 14.460 + 91 \times 0.01 = 15.370 \text{ MHz}$$

Since the mixer output is determined by two factors-the off-set frequency output (dependent on band selector switch) and the VCO output, the mixer output contains the subtracted frequencies of 0.91 to 3.15 MHz. These frequencies appear in pin #2 of IC-1 through C-82, and divided by the programmable divider in IC-1 down to 10 kHz which is compared with another 10 kHz signal obtained from the reference oscillator (10.240 MHz).

The VCO output is mixed with the off-set frequency signal and applied to the TX mixer IC-9 through band-pass filters L-43 and L-44. i.e. At channel 1 in band A, and AM band, the TX mixer IC-9 accepts $15.370 + 10.695 \text{ MHz} = 26.065 \text{ MHz}$ is TX frequency. The mixed with 10.695 MHz signal from TR-30. When receiving channel 1 in band A (26.065 MHz), the 1st RX mixer TR-18 accepts 15.370 local signal at its base, and converts down it to 10.695 MHz IF (for AM/FM modes, this is the 1st intermediate frequency). TR-18 off-sets the 10.695 MHz signal so that TR-30 can oscillate at 10.6975 MHz for LSB.

PLL CIRCUIT

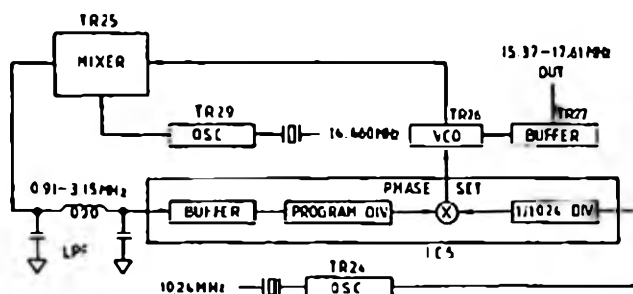

RECEIVER

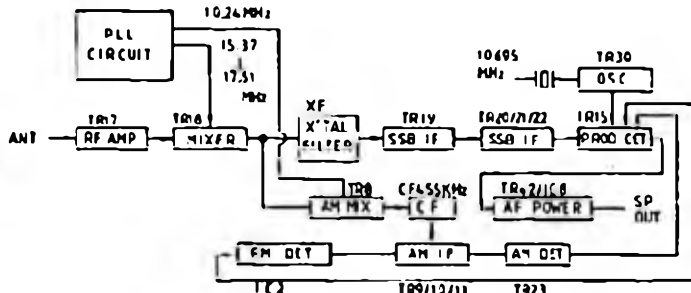

TRANSMITTER

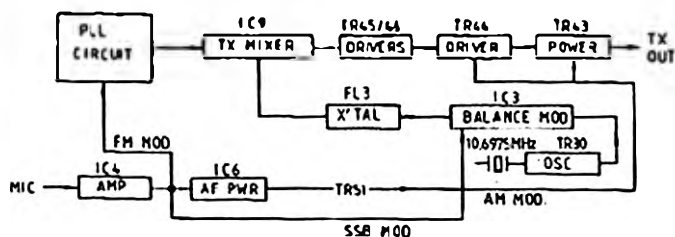

Alignment Procedure

1- Measurement Condition

(1) Reference temperature _____ 25° C

(2) Reference humidity _____ 65%

Note: Unless otherwise specified, alignment may be performed under the room temperature of 5° - 35° C and the room humidity of 45 - 80%.

3) Power supply _____ AC 110V or 220V ±3%

2- Test Equipment. All test equipment should be properly calibrated.

- 50 Ohms resistive antenna load, 20W.
- Frequency counter operable in the required frequency range.
- HF signal generator operable over 50 kHz to 60 MHz.
- Synchroscope, 0-100 MHz, high input Z.
- FM deviation meter.
- Digital voltmeter
- 8 Ohms 5W resistive speaker load.
- Two audio signal generators, 10 Hz to 20 kHz, attenuative.
- RF wattmeter, 50 ohm/15 watt, thermocoupled.
- Circuit tester, input impedance 20 kOhm/V.
- Regulated DC power supply, more than 4A.
- Dummy microphone plugs, receive and transmit mode.
- VIVM, 0.1 mV measurable.

3- PLL Circuit Alignment

A [10.24 MHz] Reference Frequency Adjustment (Check)

- Connect frequency counter to pin terminal between C-78 and C-79.
- Check counter reads 10.24000 MHz.
- Tolerance within ±200 Hz is acceptable. Otherwise, replace X 1 (10.24 MHz).

B. [10.695/10.6925/10.6975 MHz] Adjustment.

- Connect frequency counter to TP-6.
- 10.695 MHz: Set the mode selector to CW. Adjust L-26 to 10.695 MHz + 0, -100 Hz.
- 10.6925 MHz: Reset Mode Selector to USB. Adjust L-27 to 10.6925 MHz, + 0, -100 Hz.
- 10.6975 MHz: Reset Mode Selector to LSB. Adjust L-28 to 10.6975 MHz, + 0, -100 Hz.

C. PLL Input Level Adjustment

- Set the mode selector to AM, and the clarifier Control to center, and set the band selector to Position C of CH 19.
- Connect synchroscope to TP-4 (pin terminal between the C-82 and R-107).
- Adjust L-16 for maximum RF output.

D. [VCO] Adjustment

- Set the mode selector to AM, and the clarifier control to center, and set the band selector to position F with CH 40.
- Connect synchroscope to TP-3.

3) Adjust L-18 for maximum RF output.

4) Connect DC voltmeter to TP-2 (pin terminal between the R-109 and R-258 from IC-5).

5) Adjust L-17 to DC 5.0 + 0.1V.

6) Check A band of CH7, must be DC 1.5V minimum.

E. [Off-set Frequency] Adjustment

- Connect frequency counter to TP 3 (pin terminal of L-18).
- Set the Mode Selector to AM, and the Clarifier Control to center.
- Set the Band Selector to position C of CH19.
- Adjust L-19 for 16.040 MHz ±50 Hz.
- Set the mode Selector to USB.
- Adjust L-20 for 16.0425 MHz ±50 Hz.
- Set the mode Selector to LSB.
- Adjust L-21 for 16.0375 MHz ±50 Hz.
- Set the mode Selector to LSB, and transmit station.
- Adjust VR-15 for 16.0375 MHz ±50 Hz.

4.- Transmitter Alignment

A. Test set-up

Connect testing unit to the unit as shown:

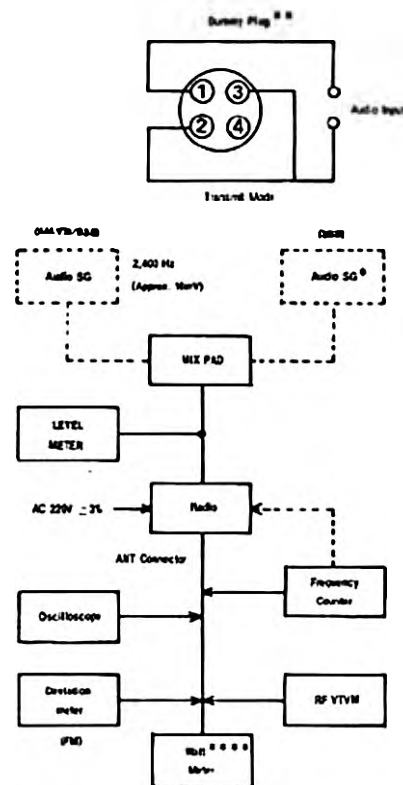

- B. RF Power Transistor of Current Adjustment**
- 1) Set the mode selector to USB, and the band selector to C of CH 19.
 - 2) Connect current meter to TP-9 (+) and TP-8 (-).
 - 3) Adjust VR 11 to 10 ± 0.5 mA.
 - 4) Connect current meter to TP-9 (+) and TP-7 (-).
 - 5) Adjust VR 10 to 100 ± 5 mA.
- C. RF Power Amplifier Adjustment**
- 1) Set the Mode Selector to USB.
 - 2) Apply 1,000 Hz 30 mV audio to microphone input circuit (use dummy microphone plug).
 - 3) Set the band Selector to E with CH40.
 - 4) Adjust VR-12 and L-42 for maximum RF output.
 - 5) Adjust L-40, L-43, L-44 and L-33 for maximum RF output.
 - 6) Repeat steps 3) through 5) until no further improvement is obtained.
 - 7) Adjust L-42 for balance of E band CH40 and A band CH1 with RF output.
- D. Two-Tone Adjustment**
- 1) Apply 500 Hz and 2,400 Hz (30 mV) audio tones to the microphone input circuit at the same time. Use two audio signal generator set with attenuators.
 - 2) Adjust test audio levels of 500 Hz generator by means of attenuator on the generator so that the scope present wave figure like 'A' as shown below.
 - 3) Adjust VR-12 to 12 W p-p power output.

- E. AM/FM/CW RF Power Output Adjustment**
- 1) Set the Mode Selector to AM.
 - 2) Select the Band Selector to C.
 - 3) Select the Channel Selector to 19.
 - 4) Adjust VR-13 for 5 W RF power output.
- F. AM Modulation Adjustment**
- 1) Apply 1,000 Hz 30 mV audio to the unit.
 - 2) Adjust VR-14 for modulation depth of greater than 90%.
- G. FM Deviation Adjustment**
- 1) Set the Mode Selector to FM.
 - 2) Apply 1,000 Hz 30 mV audio to modulation circuit. Use dummy microphone plug.
 - 3) Connect deviation meter (or linear detector) to antenna output on the unit.
 - 4) Adjust VR-5 to obtain 2-3 KHz.
- H. RF power Meter Adjustment**
- 1) Set the Mode Selector to AM.
 - 2) Comparing the reading of external RF power and the built-in meter, Adjust VR-8 for equal indication on the unit power meter.
- I. CW Tone Level Adjustment**
- 1) Set the mode selector to CW.
 - 2) Connet 8 Ohm dummy load and AF VTVM to ext S.P jack, and connect a key sw to key sw Jack.
 - 3) Key sw on and adjust VR-16 to 200 ± 10 mV.

Reference -SSB Two-Tone Alignment

Important: RV-12 (bias) Adjustment: RV-12 should not be rotated clockwise beyond 2 o'clock position, or the RF power transistor will be destroyed.

A. Properly adjusted transmitter.

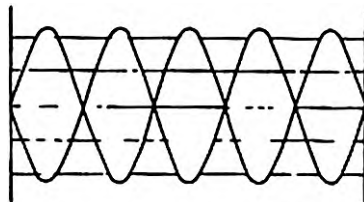

B. Unequal tones-Adjust generator outputs to balance.

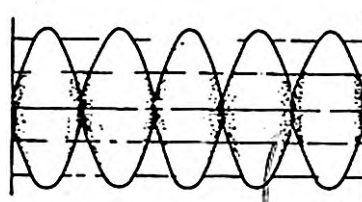

C. Excessive modulation - Adjust RV12 counterclockwise.

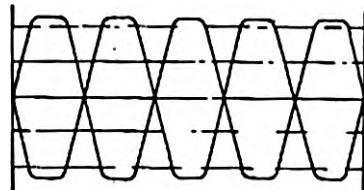

D. Final transistor incorrectly biased - Adjust RV 12.

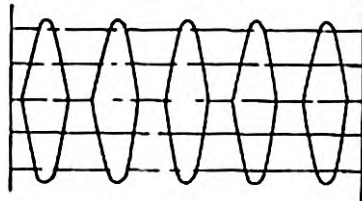

E. Undermodulation-Adjust RV 12 clockwise.

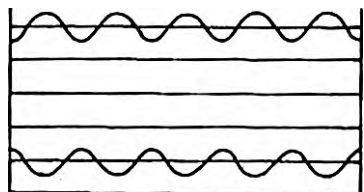

F. Similar to A but showing hum-Check for proper testing condition.

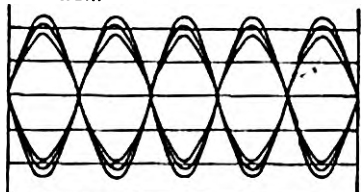

5.- Receiver Alignment

A. Test set-up

Connect testing equipment to the unit as shown:

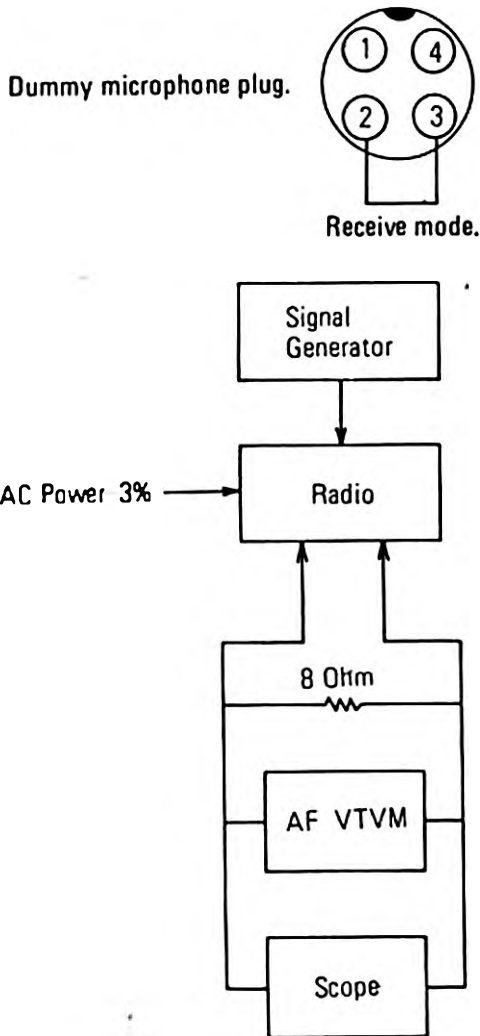

B. AM Sensitivity Adjustment

- 1) Set signal generator to 27.185 MHz 30% modulation.
- 2) Set the Channel Selector 19 in Band C.
- 3) Set the Mode Selector to AM.
- 4) Adjust L3, L4, L6, L7, L8, L10, L11, and L12 for maximum audio output from speaker output terminals (across dummy load).
NOTE: Keep generator output level as low as possible to avoid AGC action.
- 5) After completing above; adjust L-8 for balance A band and E band.

C. SSB Sensitivity Adjustment

- 1) Set signal generator to 27.186 MHz. without Modulation.
- 2) Set the Channel Selector to channel 19 in Band C.
- 3) Set the Mode Selector to USB.
- 4) Adjust L-13 and L-14 for maximum audio output. Set clarifier to center.

D. FM IF/Demodulator Alignment (FM Sensitivity Adjustment)

- 1) Select channel 19 in Band C, set the Mode Selector to FM.
- 2) Set signal-generator to 27.185 MHz.
- 3) Apply FM signal (1 μ V, 1.5 KHz deviation with 1 KHz audio) to unit.
- 4) Readjust L-5 for maximum audio output.

E. Squelch Adjustment

- 1) Set the Mode Selector to AM.
- 2) Set signal generator to provide RF input signal of 60 dB (1000 μ V), 1 KHz 30% modulated, and rotate squelch control to the fully clockwise position.
- 3) Connect scope to speaker output terminal. Adjust VR-4 to a point at which audio output is critically disappeared on scope.
Check the Squelch circuit will operate within 48-70 dB at all modes. SSB RX squelch is automatically adjust by VR-3 and requires no particular adjustment.

F. S-Meter Adjustment

- 1) Set the Mode Selector to AM.
- 2) Adjust signal generator output to 40 dB (100 μ V).
- 3) Adjust VR-1 so that S-meter indicates '9' on the unit meter scale.
- 4) Set the Mode Selector to USB.
- 5) Adjust VR-2 so that S-meter indicates '9'.

G. Noise blaker Adjustment

- 1) Set the mod selector to AM, select channel 40 in band A.
- 2) Set signal generator to 26.945 MHz (CH 39 position) without Modulation, RF input signal of 40 dB (100 μ V).
- 3) The NB/ANL SW ON.
- 4) Connet DC voltmeter to TP-1.
- 5) Adjust L-1 and L-2 to obtain DC 2-3V.

EPT360010Z Main Board

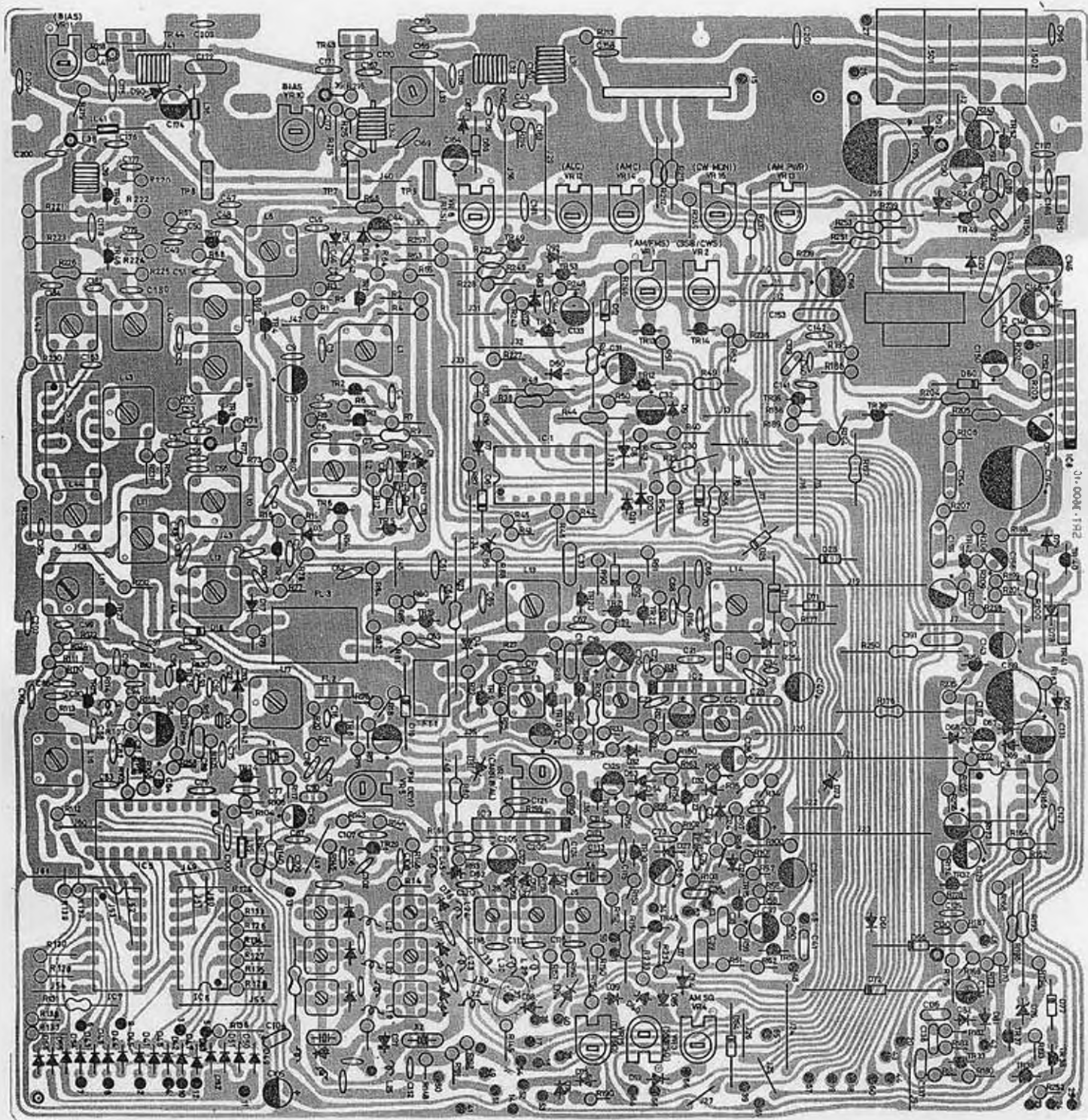

Schematic Diagram

