

PRESIDENT

BILLY



SERVICE MANUAL

1. SPECIFICATIONS

GENERAL

- | | |
|--|---|
| 1. Channels | : 40 |
| 2. Frequency Range | : 26.965 ~ 27.405MHz |
| 3. IC's | : 2 |
| 4. Crystal Oscillator | : 1 |
| 5. Microphone | : Electret Condenser Type |
| 6. Speaker | : 16 ohm , 5 Watts |
| 7. Antenna Connector | : M-Type |
| 8. Jacks & Connectors | : Microphone 4Pin Modular Jack
(6Pin Size) |
| 9. Controls | : Channel Selector Up/Down , Power Switch ,
Volume control , Squelch Control |
| 10. Illuminations | : Channel Readout (LED Red) , TX Indicator (LED Red) |
| 11. Size | : W : 120 mm.
H : 42 mm.
D : 170 mm. |
| 12. Weight | : 0.45 Kg. |
| 13. Accessories | : Microphone , Microphone Hanger ,
Mounting Bracket with Screws |
| 14. Power Source | : 13.8V DC Negative Ground ,
Reverse Polarity Protection |
| 15. Standard Operating Temp. | : -30 ~ +50° C |
| 16. Storage Temperature | : -40 ~ +70° C |
| 17. Electrostatic Discharge Protection | : All external case and component parts shall withstand
the application of 15kV ESD without causing failure or
malfunction to the unit. |
| 18. Channel Memory Backup Time | : Nom. 48 Hrs |
| <u>REMARK</u> | : Exclude Battery |

MEASUREMENT CONDITIONS

1. Power Source	: 13.8V (DC)
2. Antenna Impedance	: 50Ω
3. Test Temperature	: 25° C
4. Modulation Frequency	: 1 KHz (RX)
5. Mean Signal Input Level	: 1000μV
6. Reference Audio Output Power	: 0.5W
7. Reference Modulation Percentage	: 1 KHz , 30%
8. Audio Output Load	: 8Ω resistive (connect to inside connector)
9. Measuring Channel	: 19
10. Standard Method of Measurement	: FCC PART 95/15 EIA RS-382
11. ESD Test Condition	: Probe 150pF with 500Ω in series Test Temperature 25° C

NOTE: Limit Specifications are for measurements on all channels.

TRANSMITTER SECTION

<u>ITEM</u>	<u>UNIT</u>	<u>NOMINAL</u>	<u>LIMIT</u>
1. Frequency Tolerance at 25 °C (5 minutes after Switch on)	Hz	± 600	± 900
2. Carrier Power at No Modulation	W	4.0	3.6 to 4.4
3. Spurious Harmonic Emission	dB	-70	-60
4. Microphone sensitivity at 1KHz for 50% Mod	mV	10	20
5. Modulation Frequency Response (1KHz , 0dB Reference)			
Lower at 300Hz	dB	-3	0 to -15
Upper at 3.0KHz	dB	-3	0 to -12
6. AMC Range 50 to 100% Mod	dB	45	40
7. Hum and Noise in Transmit	dB	45	40
8. Battery Drain at No Modulation	mA	850	1300
80% Modulation	mA	1300	1700
9. Modulation Distortion	%	4.0	7.0
11. Output Protection	: Shall meet for 5 minutes for all VSWR's (around the Smith Chart) of 20:1 without damage.		
12. Output stability	at all VSWR's (around the Smith Chart) of up to 5: 1 under continuous operation of a duty cycle of 5 minutes transmitting, and 1 minute receiving.		

RECEIVER SECTION

<u>ITEM</u>	<u>UNIT</u>	<u>NOMINAL</u>	<u>LIMIT</u>
1. Max. Sensitivity	μV	0.5	1
2. Sensitivity for 10dB S+N/	μV	0.5	1
3. AGC Figure of Merit 50mV for 10dB Change in Audio Output	dB	85	75
4. Overall Audio Fidelity at 6dB down (refer to 1KHz)			
Upper Frequency	Hz	2500	2000 min.
Lower Frequency	Hz	300	500 max.
5. Adjacent Channel Selectivity (Two Signal)	dB	55	45
6. Maximum Audio Output Power	W	4.0	2.0
7. Hum and Noise Ratio at 1mV	dB	40	30
8. Squelch Sensitivity at Threshold	μV	0.5	1
9. Squelch Sensitivity at Tigh	μV	1000	250 to 4000
10. Image Rejection Ratio (900KHz)	dB	70	60
11. IF Rejection Ratio 1st and 2nd	dB	70	60
12. 1/2 IF Rejection Ratio	dB	70	60
13. Spurious response (22.73 MHz 40CH)	dB	50	40
14. Oscillator Dropout Voltage	V	9	11
15. Battery Drain (at DC Power Jack + 13.8V)			
(a) No Signal	mA	100	200
(b) Max. Power	mA	800	1000
16. Distortion	%	4	7

2. ALIGNMENT PROCEDURE

1. PLL PORTION

- | | |
|--------------|---|
| A) EQUIPMENT | STABILIZED DC POWER SUPPLY
DC VOLTMETER
RF POWER METER
OSCILLOSCOPE
FREQUENCY COUNTER
DUMMY LOAD (50Ω) |
| B) CONDITION | SUPPLY VOLTAGE : 13.8V (DC) |
| C) ALIGNMENT | |

STEP	CONDITION OF THE DEVICE	EQUIPMENT CONNECTION	ADJUSTMENT	PROCEDURE
1	TX 40CH	DC Voltmeter to TP1	L201	Adjust L201 for $1.5V \pm 0.1V$ as read on DC voltmeter.
2	RX 40CH	Ditto	L200	Similar to step 1
3	TX/RX 1~40 CH	Ditto	-	Check DC voltage of all channels for within 1.4V ~ 3.4V

NOTE 1) Frequency tolerance must meet with specification.

LOCATION OF ADJUSTMENT (PLL)

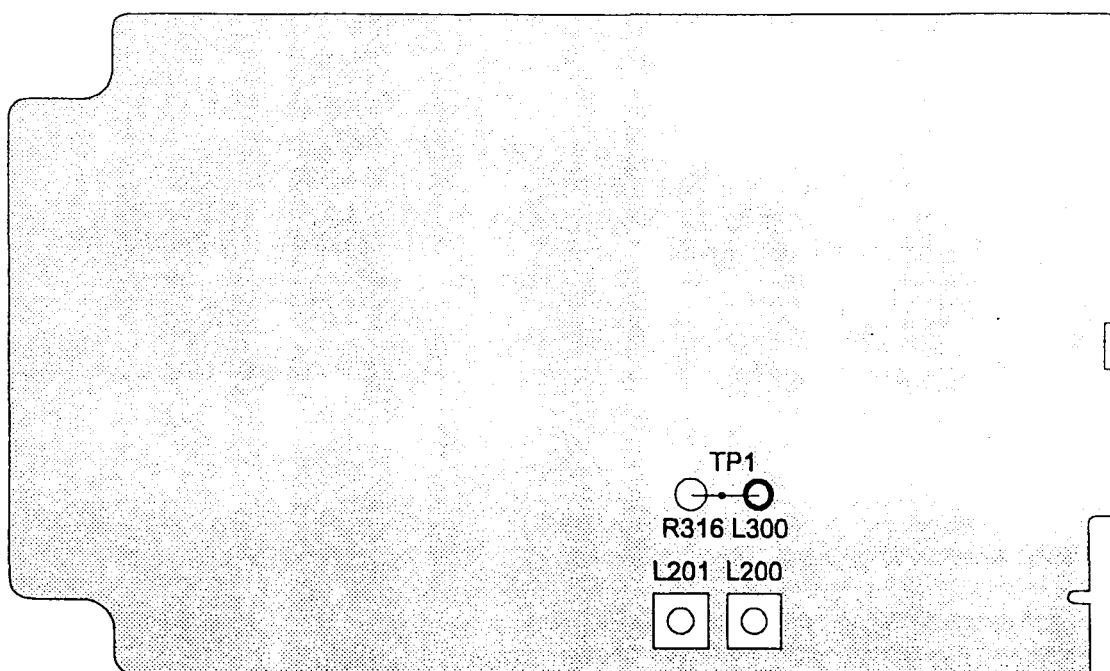

2. TRANSMITTER PORTION

A) CONDITION

SUPPLY VOLTAGE : 13.8V (DC)
 LOAD RESISTANCE : 50 Ω
 INPUT SIG. FREQ. (AF) : 1 kHz
 CHANNEL SET : 19 CH

Set controls and switches as follows unless otherwise specified.

B) ALIGNMENT

STEP	CONDITION OF THE DEVICE	EQUIPMENT CONNECTION	ADJUSTMENT	PROCEDURE
1	Input 500mV 19 CH	Connect RF PWR meter to ANT. JACK (J600)	L102 (WHT) L105 (GRN)	Maximum reading of RF PWR meter.
2	No Input (No Mod.)	Ditto	L102	Rotate the core of the L102 clockwise to read 4 Watts on RF PWR meter.
3	Ditto	Ditto	-	Confirm frequency of all channels within specification.

NOTE 2) DC stopping capacitor is required for MIC signal input line since DC current appears on Pin No. 2.

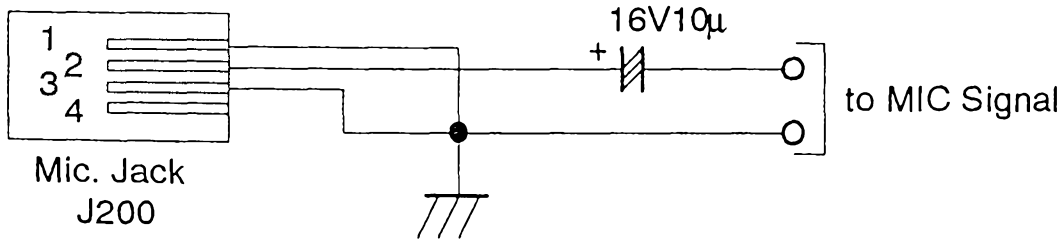

LOCATION OF ADJUSTMENT (TX)

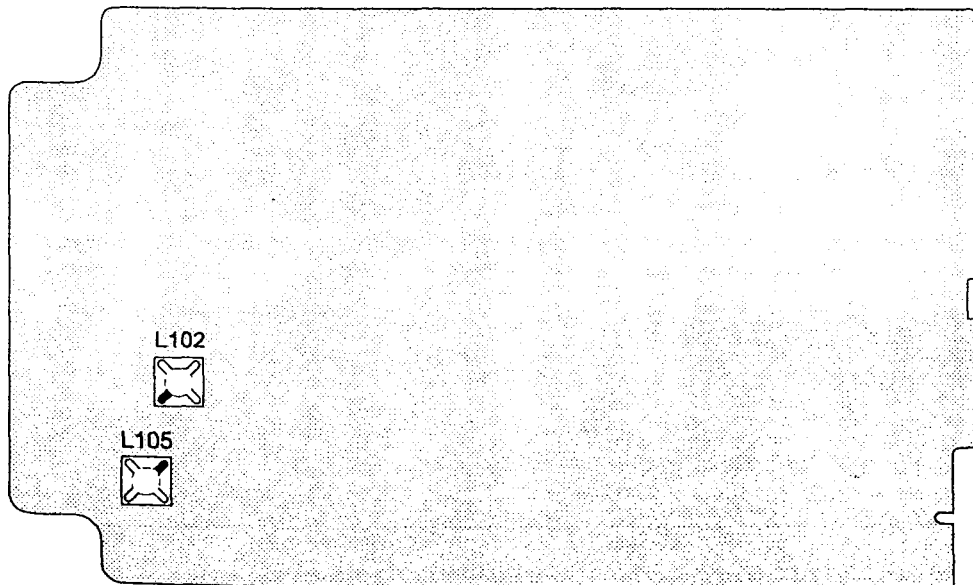

3. RECEIVER PORTION

A) CONDITION

SUPPLY VOLTAGE : 13.8V (DC) CHANNEL SET : 19 CH
 ANT. LOAD IMPEDANCE: 50 Ω RF SIGNAL FREQ. : 27.185MHz
 MOD. SIGNAL : 1 kHz, 30% Mod. RF SIG. OUTPUT : 0dB = 0.5μV
 STANDARD OUTPUT : 500 mW (2.0V) LOAD IMPEDANCE : 8 Ω

Set all controls and switches as follows unless otherwise specified.

SQUELCH : MIN.(FULLY CCW)

B) ALIGNMENT

STEP	CONDITION OF THE DEVICE	EQUIPMENT CONNECTION	ADJUSTMENT	PROCEDURE
1	19 CH Volume=Max (fully CW)	Signal Generator to J600. AC voltmeter to J201.	L2 to L5	Adjust coils to maximum reading of the AC Voltmeter. Keep RF signal level of the sign gen. to meet standard output level slightly less level during this alignme STD output at -2dB input.
2	Volume=Max SQ = Max (fully CW)	Ditto	VR1	Set RF Signal ouput level of the sign. generator to 66dB, then adjust VR1 t to just "open" squelch.

LOCATION OF ADJUSTMENT (RX)

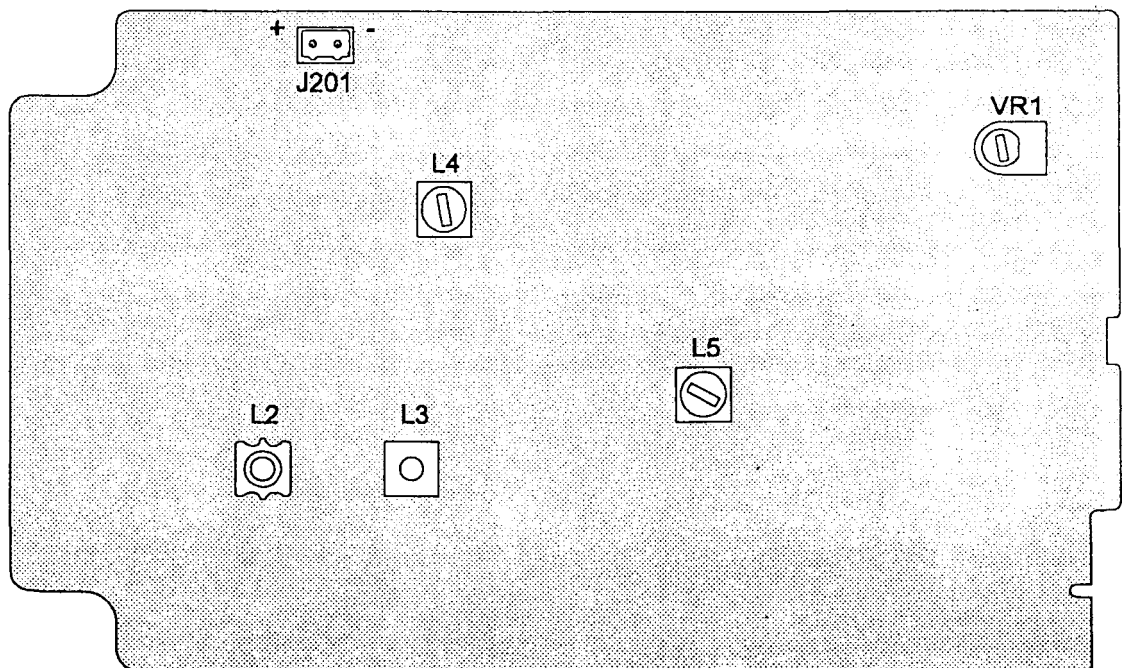

3. SEMICONDUCTOR LEAD IDENTIFICATION

DIODES
1SV68



IN4148

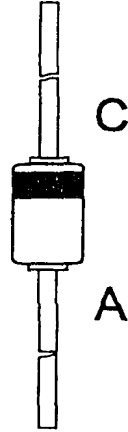

IN4003

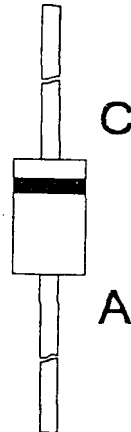

HZ3B2
HZ5B3
HZ601
HZ9B3

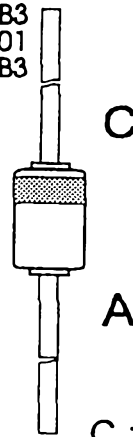

C : Cathode
A : Anode

LDR-204ALD

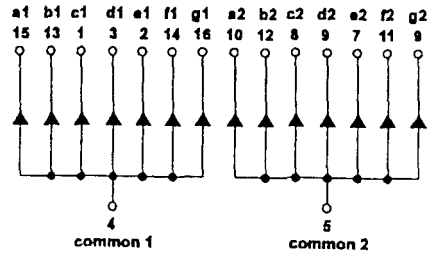
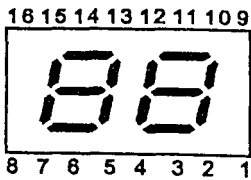

TLR-124

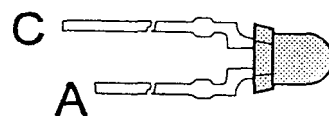

TRANSISTORS

2SC2001
2SC1675
2SA733

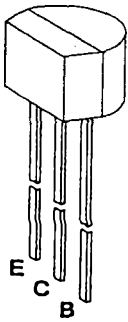

2SC945A
2SC1674

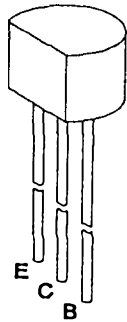

DTC144WS

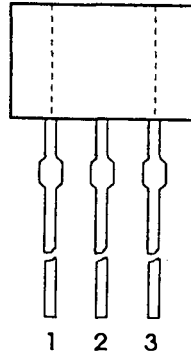

2SC2078

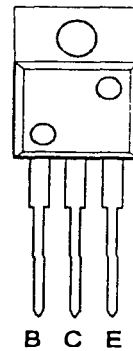

2SC2314

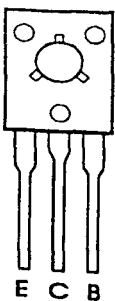

2SC941TM

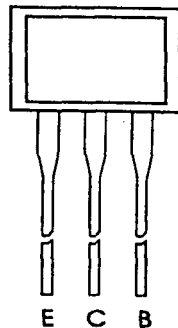

2SC3242

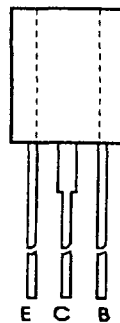

B : BASE
C : COLLECTOR
E : EMITTER

1 GND
2 OUT
3 IN

4. IC INTERNAL DIAGRAMS

SM5125AM

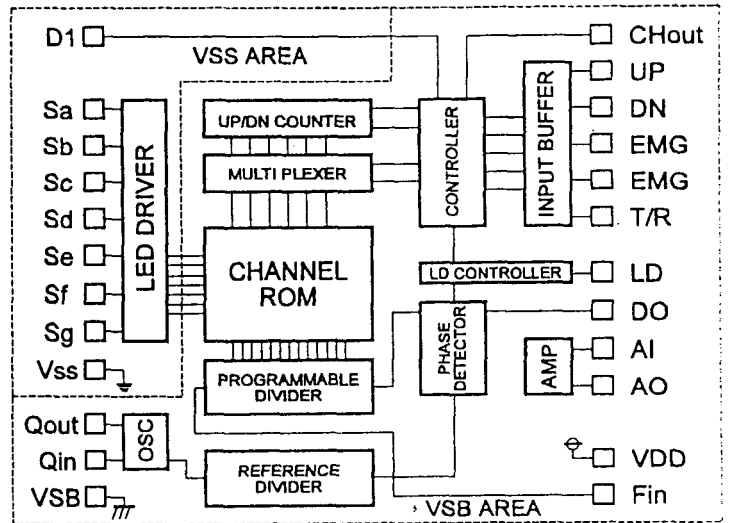
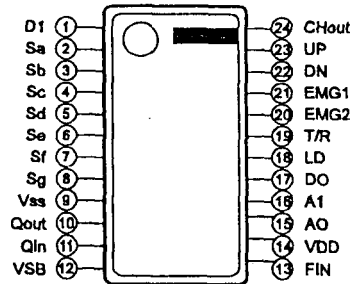

TDA1905

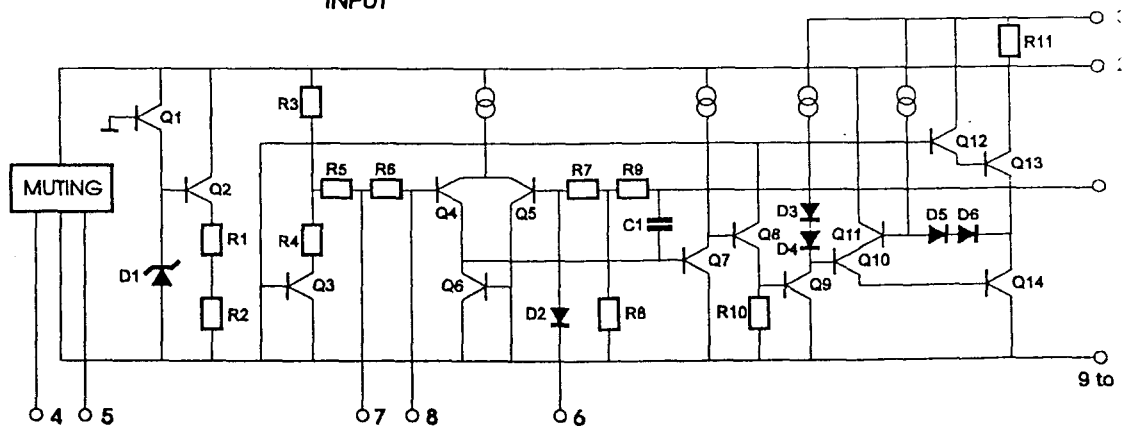
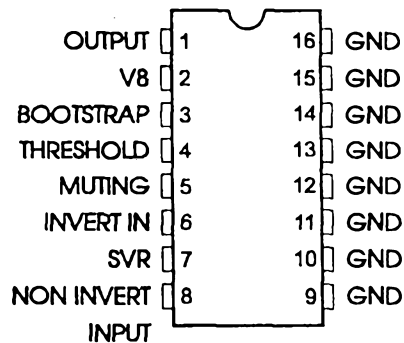

5. PARTS LIST

Parts are subject to change without prior notice.

(MODEL)

UT348ZP
(SYMBOL)

(MODEL)	(PARTS CODE)	(DESCRIPTION)	
	PRO501XL		
	GCMB130377Z	CASE:BOTTOM	ABS, BLACK
	GCMT130376Z	CASE:TOP	ABS, BLACK, SILK
	GHDL330378Z	HOLDER:LED	ABS, BLACK
	GMSC480407Z	SCREW:MOUNTING	ABS, BLACK
	GNBP330379Z	BUTTON:PUSH	ABS, BLACK
	GNBY330380Z	KNOB	ABS, BLACK
	HBCT430384Z	MOUNTING BRACKET	SPCC, 1.2T, MFZN3
	HCSR330381Z	CHASSIS:REAR	SECC, 1.0T
	HHDE430382Z	HOLDER:IC	SECC, 1.0T
	HHDP430876Z	HOLDER:PCB	SPTE, 0.5T
	HHDZ430383Z	HOLDER:BUTTON	SUS304 OR C7701R, 0.2T
	HHSK418924B	HEAT SINK	C5191R, 0.5T
	HMHG402919Z	HANGER:MICROPHONE	SPCC, 1.0T, NI
	HSDC431235Z	SHIELD CASE	SPTE 0.3T
	HSDP430877Z	SHIELD PLATE	SPTE, 0.3T
	KDPT430385Z	WINDOW	PC, 1.0T, SILK
	PLBC482147Z	LABEL:WARNING, DC CORD	PAPER, PRINT
	PLBS431081Z	LABEL:SERIAL NO	PAPER
	PLBZ431181Z	INDY 800 LABEL	POLYESTER FILM, 0.05T
	RCUN405417Z	CUSHION	NEOPRENE SP 2T
	RCUN412259Z	SPACER	NEOPRENE SP 6T
	RETC330714Z	PROTECTION COVER	COATED BOARD
	SSCW430050N	HEX NUT	M5 NI
	UBUD429900Z	INDY 800 CARD	PAPER
	UTUD01348ZA	OWNER'S MANUAL	**
	UTYY58000ZB	FCC RULES PART 95	**
	VNYL2323758	VINYL BAG	320X370X580X0.07T
	VNYL3101500	VINYL BAG	100X150X0.1T
	VNYL3102500	VINYL BAG	100X250X0.1T
	VNYL3203000	VINYL BAG	200X300X0.1T
	WBXC330424Z	DISPLAY BOX	**
	WCTZ430425Z	SHIPPING CARTON BOX	**
	WSFC330426Z	STYROFOAM PAD	**
	WSLV418706Z	SLEEVE	**
	SSCW193008N	SCREW: BIND HD +	M3X8 NI
	SSCW295010N	SCREW:TAPPING ROUND HD +	D5X10 NI
	SSCW343006N	SCREW:TAPTIGHT BIND HD +	M3X6 NI
	SSCW540050N	WASHER:STAR	D5 NI
	SSCW803006N	SCREW:P TIGHT BIND HD +	D3X6 NI
	SSCW803008N	SCREW:P TIGHT BIND HD +	D3X8 NI
	SSCW803014N	SCREW:P TIGHT BIND HD +	D3X14 NI
C001	BCHR811804Z	CAPACITOR:CERAMIC TS 2.5 S	18PF 50V J RH TAPING
C002	BCKM811026Z	CAPACITOR:CERAMIC TS 2.5 S	0.001UF 50V M YD(D) TAPING
C003	BCKQ811030Z	CAPACITOR:CERAMIC TS 5.0 S	0.01UF 50V Z YF TAPING
C004	BCKM811026Z	CAPACITOR:CERAMIC TS 2.5 S	0.001UF 50V M YD(D) TAPING
C005	BCAB811006Z	C:ELCT TS2.5C+ (D5*11)	10UF 50V M TAPE
C007	BCKQ811030Z	CAPACITOR:CERAMIC TS 5.0 S	0.01UF 50V Z YF TAPING
C008	BCHG812214Z	CAPACITOR:CERAMIC TS 5.0 S	220PF 50V J SL TAPING
C009	BCKM811026Z	CAPACITOR:CERAMIC TS 2.5 S	0.001UF 50V M YD(D) TAPING
C010	BCKQ812230Z	CAPACITOR:CERAMIC TS 5.0 S	0.022UF 50V Z YF TAPING
C011	BCKQ811030Z	CAPACITOR:CERAMIC TS 5.0 S	0.01UF 50V Z YF TAPING

(SYMBOL)	(PARTS CODE)	(DESCRIPTION)	
C012	BCKQ814730Z	CAPACITOR:CERAMIC	TS 5.0 S 0.047UF 50V Z YF TAP
C014	BCGG514735Z	C:SEMI-CONDUCTOR(SR)	TS 5.0 S 0.047UF 25V K TAPING
C015	BCAB814796Z	C:ELCT TS2.5C+ (D5*11)	4.7UF 50V M TAPE
C016	BCKQ814730Z	CAPACITOR:CERAMIC	TS 5.0 S 0.047UF 50V Z YF TAP
C017	BCKM811026Z	CAPACITOR:CERAMIC	TS 2.5 S 0.001UF 50V M YD(D)T/
C018	BCAB811006Z	C:ELCT TS2.5C+ (D5*11)	10UF 50V M TAPE
C019	BCKM811026Z	CAPACITOR:CERAMIC	TS 2.5 S 0.001UF 50V M YD(D)T/
C020	BCAB811096Z	C:ELCT TS2.5C+ (D5*11)	1UF 50V M TAPE
C021	BCKQ811030Z	CAPACITOR:CERAMIC	TS 5.0 S 0.01UF 50V Z YF TAPI
C022	BCKQ814720Z	CAPACITOR:CERAMIC	TS 2.5 S 0.0047UF 50V Z YF TAF
C023	BCGG514725Z	C:SEMI CONDUCTOR(SR)	TS 2.5 S 0.0047UF 25V K TAPING
C024	BCAB812296Z	C:ELCT TS2.5C+ (D5*11)	2.2UF 50V M TAPE
C030	BCKQ811030Z	CAPACITOR:CERAMIC	TS 5.0 S 0.01UF 50V Z YF TAPI
C031	BCAB514706Z	C:ELCT TS2.5C+ (D5*11)	47UF 25V M TAPE
C032	BCKM811026Z	CAPACITOR:CERAMIC	TS 2.5 S 0.001UF 50V M YD(D)T/
C033	BCHC816804Z	CAPACITOR:CERAMIC	TS 5.0 S 68PF 50V J CH TAPIN
C101	BCHC812214Z	CAPACITOR:CERAMIC	TS 5.0 S 220PF 50V J CH TAPE
C102	BCHC815604Z	CAPACITOR:CERAMIC	TS 5.0 S 56PF 50V J CH TAPIN
C103	BCHC812214Z	CAPACITOR:CERAMIC	TS 5.0 S 220PF 50V J CH TAPE
C104	BCKM811026Z	CAPACITOR:CERAMIC	TS 2.5 S 0.001UF 50V M YD(D)T/
C105	BCKM811036Z	CAPACITOR:CERAMIC	TS 5.0S 0.01UF 50V M YD(D)TA
C106	BCHU812704Z	CAPACITOR:CERAMIC	TS 2.5 S 27PF 50V J UJ TAPIN/
C108	BCHU812214Z	CAPACITOR:CERAMIC	TS 5.0 S 220PF 50V J UJ TAPIN
C109	BCKQ811030Z	CAPACITOR:CERAMIC	TS 5.0 S 0.01UF 50V Z YF TAPI
C110	BCKQ814720Z	CAPACITOR:CERAMIC	TS 2.5 S 0.0047UF 50V Z YF TAF
C111	BCKM811026Z	CAPACITOR:CERAMIC	TS 2.5 S 0.001UF 50V M YD(D)T/
C112	BCKQ811030Z	CAPACITOR:CERAMIC	TS 5.0 S 0.01UF 50V Z YF TAPI
C113	BCHU814714Z	CAPACITOR:CERAMIC	TS 5.0 S 470PF 50V J UJ
C114	BCKQ811030Z	CAPACITOR:CERAMIC	TS 5.0 S 0.01UF 50V Z YF TAPI
C115	BCKM811026Z	CAPACITOR:CERAMIC	TS 2.5 S 0.001UF 50V M YD(D)T/
C116	BCHU811804Z	CAPACITOR:CERAMIC	TS 2.5 S 18PF 50V J UJ TAPING
C200	BCAW514716Z	C:ELCT TS5.0S+ (D5*11)	470UF 25V M TAPE
C201	BCGG511045Z	C:SEMI-CONDUCTOR(SR)	TS 5.0 S 0.1UF 25V K TAPING
C202	BCAV112216Z	C:ELCT TS2.5S+ (D5*11)	220UF 10V M TAPE
C203	BCAB812296Z	C:ELCT TS2.5C+ (D5*11)	2.2UF 50V M TAPE
C204	BCAP511026Z	CAPACITOR:ELECTROLYTIC	1000UF 25V M C-130
C205	BCAB811096Z	C:ELCT TS2.5C+ (D5*11)	1UF 50V M TAPE
C207	BCGG511045Z	C:SEMI-CONDUCTOR(SR)	TS 5.0 S 0.1UF 25V K TAPING
C208	BCGG514725Z	C:SEMI CONDUCTOR(SR) T	S 2.5 S 0.0047UF 25V K TAPING
C209	BCGG514735Z	C:SEMI-CONDUCTOR(SR)	TS 5.0 S 0.047UF 25V K TAPING
C210	BCKM811026Z	CAPACITOR:CERAMIC	TS 2.5 S 0.001UF 50V M YD(D)T/
C212	BCAB513306Z	C:ELCT TS2.5C+ (D5*11)	33UF 25V M TAPE
C213	BCGG512225Z	C:SEMI CONDUCTOR(SR)	TS 2.5 S 0.0022UF 25V K TAPINC
C214	BCGG513325Z	C:SEMI CONDUCTOR(SR)	TS 2.5 S 0.0033UF 25V K TAPING
C215	BCKQ814720Z	CAPACITOR:CERAMIC	TS 2.5 S 0.0047UF 50V Z YF TAF
C217	BCAB514706Z	C:ELCT TS2.5C+ (D5*11)	47UF 25V M TAPE
C218	BCKQ811030Z	CAPACITOR:CERAMIC	TS 5.0 S 0.01UF 50V Z YF TAPII
C219	BCKM811026Z	CAPACITOR:CERAMIC	TS 2.5 S 0.001UF 50V M YD(D)T/
C220	"	"	"
C300	B CKQ814720Z	CAPACITOR:CERAMIC	TS 2.5 S 0.0047UF 50V Z YF TAI
C301	BCHC813304Z	CAPACITOR:CERAMIC	TS 2.5 S 33PF 50V J CH TAPIN/
C302	BCAB812296Z	C:ELCT TS2.5C+ (D5*11)	2.2UF 50V M TAPE
C303	"	"	"
C304	BCKM811026Z	CAPACITOR:CERAMIC	TS 2.5 S 0.001UF 50V M YD(D)T/
C305	BCHC812714Z	CAPACITOR:CERAMIC	TS 5.0 S 270PF 50V J CH TAPE
C306	BCHG813314Z	CAPACITOR:CERAMIC	TS 5.0 S 330PF 50V J SL TAPIN
C307	BCKQ814730Z	CAPACITOR:CERAMIC	TS 5.0 S 0.047UF 50V Z YF TAF
C308	BCGG514735Z	C:SEMI-CONDUCTOR(SR)	TS 5.0 S 0.047UF 25V K TAPING

(SYMBOL)	(PARTS CODE)	(DESCRIPTION)	
C309	BCAV903316Z	C:ELCT TS2.5S+ (D5*11)	330UF 6.3V M TAPE
C310	BCKQ811030Z	CAPACITOR:CERAMIC	TS 5.0 S 0.01UF 50V Z YF TAPING
C311			
C312	BCHU814704Z	CAPACITOR:CERAMIC	TS 2.5 S 47PF 50V J UJ TAPE
C313	BCKQ811030Z	CAPACITOR:CERAMIC	TS 5.0 S 0.01UF 50V Z YF TAPING
C314	BCHU813904Z	CAPACITOR:CERAMIC	TS 2.5 S 39PF 50V J UJ TAPING
C315	BCHU813314Z	CAPACITOR:CERAMIC	TS 5.0 S 330PF 50V J UJ TAPING
C316	BCHU811014Z	CAPACITOR:CERAMIC	TS 5.0 S 100PF 50V J UJ TAPING
C317	BCHG816804Z	CAPACITOR:CERAMIC	TS 2.5 S 68PF 50V J SL TAPE
C318	BCHC811504Z	CAPACITOR:CERAMIC	TS 2.5 S 15PF 50V J CH TAPING
C319	BCHG813904Z	CAPACITOR:CERAMIC	TS 2.5 S 39PF 50V J SL TAPING
C320	BCKQ811030Z	CAPACITOR:CERAMIC	TS 5.0 S 0.01UF 50V Z YF TAPING
C322	BCAV112216Z	C:ELCT TS2.5S+ (D5*11)	220UF 10V M TAPE
C400	BCKQ814720Z	CAPACITOR:CERAMIC	TS 2.5 S 0.0047UF 50V Z YF TAPING
C401	BCAB514706Z	C:ELCT TS2.5C+ (D5*11)	47UF 25V M TAPE
C402			
C403	BCAV311016Z	C:ELCT TS2.5S+ (D5*11)	100UF 16V M TAPE
C404	BCKQ811030Z	CAPACITOR:CERAMIC	TS 5.0 S 0.01UF 50V Z YF TAPING
C405	BCKM811026Z	CAPACITOR:CERAMIC	TS 2.5 S 0.001UF 50V M YD(D)TAPING
C600	BCCU811514Z	CAPACITOR:CERAMIC	150PF 50V J UJ
D001	BDAY0246003	DIODE:AXIAL TAPING 26MM	1N4148 T-77
D002			
D005			
D100			
D101			
D200	BDAY0060003	DIODE	1N4003
D201	BDAY0246003	DIODE:AXIAL TAPING 26MM	1N4148 T-77
D301			
D302	BDAY0492019	DIODE:ZENER AX TS 26+	HZ-6C1 TD
D303	BDAY0333001	DIODE:VARICAP	1SV68
D304	BDAY0492001	DIODE:ZENER AX TS 26 +	HZ5B3 TAPING
D305	BDAY0246002	DIODE:AXIAL TAPING 52MM	1N4148 T-72
D400	BDAY0492010	DIODE:ZENER AX TS 26 +	HZ9B3 TD
D401	BDAY0060003	DIODE	1N4003
D500	BDAY0100001	DIODE:LED	TLR-124
D501	BDAY0202001	DIODE:LED	LDR-204ALD
J200	BJKY0458004	JACK:TEL	JK-458 CSK290-623-04-235
J201	BJKY0571002	JACK	JK-571 2P
J600	BJKY0425001	JACK:ANT	JK-425 M-RM-L 102
L002	BLBY1027001	COIL	LB-1027
L003	BLBY1030001	COIL	LB-1030
L004	BLBY1029001	COIL	LB-1029
L005	BLBY1028001	COIL	LB-1028
L100	BLEY0419001	COIL	LE-419 11 1/2T
L101	BLEY0435001	COIL	LE-435 10 1/2T
L102	BLCY0228001	COIL	LC-228 L-1S7-T(R12-J840X)
L103	BLDY0237001	COIL	LD-237 L-2R4W(R22-E563)
L104	BLDY0087001	COIL	LD-087 BF04-3*5*1
L105	BLCY0199001	COIL	LC-199 L-2S7-T(R12E831X)
L106	BLEY0286001	COIL	LE-286 D4 6 1/2T
L107	BLDY0087001	COIL	LD-087 BF04-3*5*1
L200	BLBY0724001	COIL	LB-724 L-2M7-D3
L201	BLBY0723001	COIL	LB-723 L-2M7-D3
L202	BLDY0087001	COIL	LD-087 BF04-3*5*1
L203			
L300			
L301	BLZY0041100	INDUCTOR:MOLDED	LZ-041 10UH
L400	BLDY0087001	COIL	LD-087 BF04-3*5*1

(SYMBOL)	(PARTS CODE)	(DESCRIPTION)	
Q001	BDBX1674111	TRANSISTOR:RH TS +	DB-6009 2SC1674-L TAPIN
Q002	BDBX1675111	TRANSISTOR:RH TS +	DB-259 2SC1675-L TAPIN
Q003	"	"	"
Q005	"	"	"
Q006	BDBX0945507	TRANSISTOR:RH TS +	DB-6008 2SC945A-Q TAPIN
Q007	"	"	"
Q100	BDBC2078105	TRANSISTOR	DB-791 2SC2078E
Q101	BDBC2314106	TRANSISTOR	DB-792 2SC2314F
Q102	BDBX0941523	TRANSISTOR:RH TS +	DB-301 2SC941TM-O TAPIN
Q103	BDBX1675111	TRANSISTOR:RH TS +	DB-259 2SC1675-L TAPIN
Q200	BDBX2001111	TRANSISTOR	DB-822 2SC2001-L TAPIN
Q300	BDBX1675111	TRANSISTOR:RH TS +	DB-259 2SC1675-L TAPIN
Q301	"	"	"
Q302	"	"	"
Q303	BDBV0733115	TRANSISTOR:RH TS +	DB-6007 2SA733-P TAPIN
Q304	"	"	"
Q305	BDBX0945507	TRANSISTOR:RH TS +	DB-6008 2SC945A-Q TAPIN
Q306	BDBZ0668001	TRANSISTOR	DB-668 DTC144WS TAPE
Q400	BDBV0733115	TRANSISTOR:RH TS +	DB-6007 2SA733-P TAPIN
Q401	BDBC3242536	TRANSISTOR	DB-383 2SC3242A-E
R001	BRFT144714Z	R:CARBON AXIAL LEAD(TAPE)	470 1/4W J
R002	BRPA615624Z	RESISTOR:CARBON AX TS 26	5.6K 1/6W J TAPIN
R003	BRPA613324Z	RESISTOR:CARBON AX TS 26	3.3K 1/6W J TAPIN
R004	BRPA615614Z	RESISTOR:CARBON AX TS 26	560.1/6W J TAPIN
R005	BRFT142214Z	R:CARBON AXIAL LEAD(TAPE)	220 1/4W J
R006	BRPA611024Z	RESISTOR:CARBON AX TS 26	1K 1/6W J TAPIN
R007	BRPA613324Z	RESISTOR:CARBON AX TS 26	3.3K 1/6W J TAPIN
R008	BRPA613394Z	RESISTOR:CARBON AX TS 26	3.3 1/6W J TAPIN
R009	BRPA611024Z	RESISTOR:CARBON AX TS 26	1K 1/6W J TAPIN
R010	BRPA614714Z	RESISTOR:CARBON AX TS 26	470 1/6W J TAPIN
R011	"	"	"
R012	BRPA613314Z	RESISTOR:CARBON AX TS 26	330 1/6W J TAPIN
R013	BRPA611844Z	RESISTOR:CARBON AX TS 26	180K 1/6W J TAPIN
R014	BRPA616804Z	RESISTOR:CARBON AX TS 26	68 1/6W J TAPIN
R015	BRPA616814Z	RESISTOR:CARBON AX TS 26	680 1/6W J TAPIN
R016	BRPA611024Z	RESISTOR:CARBON AX TS 26	1K 1/6W J TAPIN
R017	BRPA611834Z	RESISTOR:CARBON AX TS 26	18K 1/6W J TAPIN
R018	BRPA612224Z	RESISTOR:CARBON AX TS 26	2.2K 1/6W J TAPIN
R019	BRPA611014Z	RESISTOR:CARBON AX TS 26	100 1/6W J TAPIN
R020	BRPA613314Z	RESISTOR:CARBON AX TS 26	330 1/6W J TAPIN
R021	BRPA611014Z	RESISTOR:CARBON AX TS 26	100 1/6W J TAPIN
R022	BRPA611834Z	RESISTOR:CARBON AX TS 26	18K 1/6W J TAPIN
R023	BRPA612234Z	RESISTOR:CARBON AX TS 26	22K 1/6W J TAPIN
R024	BRFT141034Z	R:CARBON AXIAL LEAD(TAPE)	10K 1/4W J
R025	BRPA613334Z	RESISTOR:CARBON AX TS 26	33K 1/6W J TAPIN
R026	BRPA616834Z	RESISTOR:CARBON AX TS 26	68K 1/6W J TAPIN
R027	BRPA615634Z	RESISTOR:CARBON AX TS 26	56K 1/6W J TAPIN
R028	"	"	"
R029	"	"	"
R030	BRPA616834Z	RESISTOR:CARBON AX TS 26	68K 1/6W J TAPIN
R031	BRPA618244Z	RESISTOR:CARBON AX TS 26	820K 1/6W J TAPIN
R032	BRPA613314Z	RESISTOR:CARBON AX TS 26	330 1/6W J TAPIN
R033	BRPA611524Z	RESISTOR:CARBON AX TS 26	1.5K 1/6W J TAPIN
R034	BRPA611034Z	RESISTOR:CARBON AX TS 26	10K 1/6W J TAPIN
R035	"	"	"
R036	BRPA612734Z	RESISTOR:CARBON AX TS 26	27K 1/6W J TAPIN
R037	BRPA614734Z	RESISTOR:CARBON AX TS 26	47K 1/6W J TAPIN

(SYMBOL)	(PARTS CODE)	(DESCRIPTION)	
R038	BRPA611034Z	RESISTOR:CARBON AX TS 26	10K 1/6W J TAPING
R040	BRFT143314Z	R:CARBON AXIAL LEAD(TAPE)	330 1/4W J
R041	BRPA611014Z	RESISTOR:CARBON AX TS 26	100 1/6W J TAPING
R042	BRPA614744Z	RESISTOR:CARBON AX TS 26	470K 1/6W J TAPING
R100	BRPA612224Z	RESISTOR:CARBON AX TS 26	2.2K 1/6W J TAPING
R101	BRSJ002214Z	RESISTOR:METAL OXIDE	220 1WS J
R102	BRPA611804Z	RESISTOR:CARBON AX TS 26	18 1/6W J TAPING
R103	BRPA612294Z	RESISTOR:CARBON AX TS 26	2.2 1/6W J TAPING
R104	BRPA614794Z	RESISTOR:CARBON AX TS 26	4.7 1/6W J TAPING
R105	BRPA612214Z	RESISTOR:CARBON AX TS 26	220 1/6W J TAPING
R106	BRPA611014Z	RESISTOR:CARBON AX TS 26	100 1/6W J TAPING
R107	BRPA613304Z	RESISTOR:CARBON AX TS 26	33 1/6W J TAPING
R108	BRPA618224Z	RESISTOR:CARBON AX TS 26	8.2K 1/6W J TAPING
R109	BRPA611534Z	RESISTOR:CARBON AX TS 26	15K 1/6W J TAPING
R110	BRPA611814Z	RESISTOR:CARBON AX TS 26	180 1/6W J TAPING
R111	"	"	"
R112	BRPA615624Z	RESISTOR:CARBON AX TS 26	5.6K 1/6W J TAPING
R113	BRPA611034Z	RESISTOR:CARBON AX TS 26	10K 1/6W J TAPING
R114	BRPA611534Z	RESISTOR:CARBON AX TS 26	15K 1/6W J TAPING
R116	BRPA611514Z	RESISTOR:CARBON AX TS 26	150 1/6W J TAPING
R200	BRPA611594Z	RESISTOR:CARBON AX TS 26	1.5 1/6W J TAPING
R201	BRPA611044Z	RESISTOR:CARBON AX TS 26	100K 1/6W J TAPING
R202	BRPA611014Z	RESISTOR:CARBON AX TS 26	100 1/6W J TAPING
R204	BRPA615634Z	RESISTOR:CARBON AX TS 26	56K 1/6W J TAPING
R205	BRPA613324Z	RESISTOR:CARBON AX TS 26	3.3K 1/6W J TAPING
R206	BRPA612244Z	RESISTOR:CARBON AX TS 26	220K 1/6W J TAPING
R207	BRPA611834Z	RESISTOR:CARBON AX TS 26	18K 1/6W J TAPING
R208	BRPA612224Z	RESISTOR:CARBON AX TS 26	2.2K 1/6W J TAPING
R209	"	"	"
R210	BRFT142234Z	R:CARBON AXIAL LEAD(TAPE)	22K 1/4W J
R211	BRPA616824Z	RESISTOR:CARBON AX TS 26	6.8K 1/6W J TAPING
R212	BRPA611524Z	RESISTOR:CARBON AX TS 26	1.5K 1/6W J TAPING
R213	BRPA612224Z	RESISTOR:CARBON AX TS 26	2.2K 1/6W J TAPING
R220	BRPA613954Z	RESISTOR:CARBON AX TS 26	3.9M 1/6W J TAPING
R300	BRPA612224Z	RESISTOR:CARBON AX TS 26	2.2K 1/6W J TAPING
R301	BRPA611034Z	RESISTOR:CARBON AX TS 26	10K 1/6W J TAPING
R302	BRPA615614Z	RESISTOR:CARBON AX TS 26	560 1/6W J TAPING
R303	"	"	"
R309	BRPA611514Z	RESISTOR:CARBON AX TS 26	150 1/6W J TAPING
R310	BRPA611034Z	RESISTOR:CARBON AX TS 26	10K 1/6W J TAPING
R311	BRPA611514Z	RESISTOR:CARBON AX TS 26	150 1/6W J TAPING
R312	BRPA616824Z	RESISTOR:CARBON AX TS 26	6.8K 1/6W J TAPING
R313	BRPA611034Z	RESISTOR:CARBON AX TS 26	10K 1/6W J TAPING
R315	BRPA615634Z	RESISTOR:CARBON AX TS 26	56K 1/6W J TAPING
R316	BRFT141034Z	R:CARBON AXIAL LEAD(TAPE)	10K 1/4W J
R317	BRPA613314Z	RESISTOR:CARBON AX TS 26	330 1/6W J TAPING
R318	BRPA611534Z	RESISTOR:CARBON AX TS 26	15K 1/6W J TAPING
R319	BRPA611014Z	RESISTOR:CARBON AX TS 26	100 1/6W J TAPING
R320	BRPA613914Z	RESISTOR:CARBON AX TS 26	390 1/6W J TAPING
R321	BRPA613934Z	RESISTOR:CARBON AX TS 26	39K 1/6W J TAPING
R322	BRPA611014Z	RESISTOR:CARBON AX TS 26	100 1/6W J TAPING
R324	BRPA611024Z	RESISTOR:CARBON AX TS 26	1K 1/6W J TAPING
R325	BRPA611034Z	RESISTOR:CARBON AX TS 26	10K 1/6W J TAPING
R326	BRPA611024Z	RESISTOR:CARBON AX TS 26	1K 1/6W J TAPING
R400	BRPA611014Z	RESISTOR:CARBON AX TS 26	100 1/6W J TAPING
R401	BRPA613324Z	RESISTOR:CARBON AX TS 26	3.3K 1/6W J TAPING
R402	BRPA615614Z	RESISTOR:CARBON AX TS 26	560 1/6W J TAPING
R403	BRPA612214Z	RESISTOR:CARBON AX TS 26	220 1/6W J TAPING

(SYMBOL)	(PARTS CODE)	(DESCRIPTION)	
R404	BRPA611034Z	RESISTOR:CARBON	AX TS 26 10K 1/6W J TAF
S300	BSWY0599001	SWITCH:TACT	SW-599 KHH-905
S301	"	"	"
S400	BSWY0769001	SWITCH:SLIDE	SW-769
T200	BTFY0375001	TRANSFORMER:OUTPUT	TF-375
T400	BTFY0374001	TRANSFORMER	TF-374
	CUFJ003041Z	WIRE	UL 1430 #24 10- 30- 3 WHT
X300	BQXY0308001	CRYSTAL	QX-308 10.2419M
FT001	BFLY0048001	FILTER:CERAMIC	FL-048 SFE10.7MS2-M
FT002	BFLY0231001	FILTER:CERAMIC	FL-231 CFU450HT 450KHZ
IC200	BDEY0603001	INTEGRATED CIRCUIT	TDA1905
IC300	BDEY2519003	INTEGRATED CIRCUIT	SM5125AM-E2
MK600	BMKY0466001	MICROPHONE	MK-466 EMC 556-Z001
PC001	BPAY0362AA1	PC BOARD:MAIN	PA-362AA 1/2
SP600	BSPY0312001	SPEAKER	SP-312 UN-S08F03
VR001	BRTY0552503	RESISTOR:SEMI-FIXED	RT-552 50KB
VR002	BRVY0823001	VOLUME	RV-823 50KA
VR003	BRVY0822001	VOLUME	RV-822 50KB
	CZDZ072028Z	WIRES:ASSEMBLED	W-072028
WP600	BWZY1105001	CORD:DC	WZ-1105 1500 W/P
YY600	BYDY0042001	INSULATION SHEET	YD-042
YY601	BYDY0010003	INSULATION SHEET	YD-010 P101KD

6. EXPLODED VIEW & MECHANICAL PARTS LIST

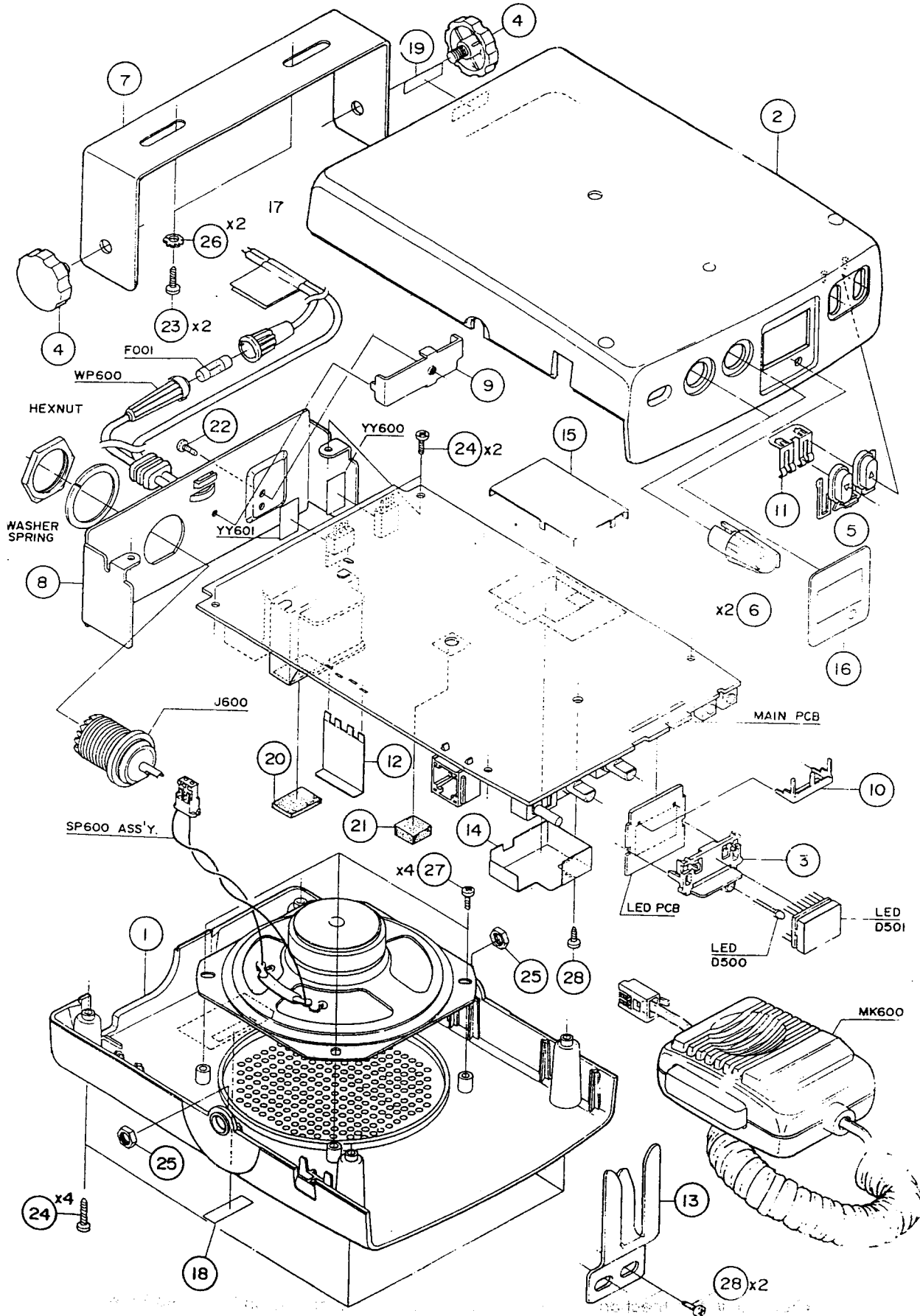

MECHANICAL PARTS LIST

(REF #)	(PARTSCODE)	(DESCRIPTION)	
1	GCMB130377Z	CASE : BOTTOM	ABS, BLACK
2	GCMT130376Z	CASE : TOP	ABS, BLACK, SILK
3	GHDL330378Z	HOLDER : LED	ABS, BLACK
4	GMSC480407Z	SCREW : MOUNTING	ABS, BLACK
5	GNBP330379Z	BUTTON, PUSH	ABS, BLACK
6	GNBY330380Z	KNOB	ABS, BLACK
7	HBCT430384Z	MOUNTING BRACKET	SPCC, 1.2T, MFZN3
8	HCSR330381Z	CHASSIS : REAR	SECC, 1.0T
9	HHDE430382Z	HOLDER : IC	SECC, 1.0T
10	HHDP430876Z	HOLDER : PCB	SPTTE, 0.5T
11	HHDZ430383Z	HOLDER : BUTTON	SUS304 ORC7701R, C
12	HHSK418924B	HEAT SINK	C5191R, 0.5T
13	HMHG402919Z	HANGER : MICROPHONE	SPCC, 1.0T, NI
14	HSDC431235Z	SHIELD CASE	SPTTE 0.3T
15	HSDP430877Z	SHIELD PLATE	SPTTE 0.3T
16	KDPT430385Z	WINDOW	PC, 1.0T, SILK
17	PLBC482147Z	LABEL : WARNING, DC CORD	PAPER, PRINT
18	PLBS431081Z	LABEL : SERIAL NO.	PAPER
19	PLBZ431181Z	INDY 800 LABEL	POLYESTER FILM, 0.
20	RCUN405417Z	CUSHION	NEOPRENE SP 2T
21	RCUN412259Z	SPACER	NEOPRENE SP 6T
22	SSCW193008N	SCREW : BIND HD +	M3x8 NI
23	SSCW295010N	SCREW : TAPPING ROUND HD +	D5x10 NI
24	SSCW343006N	SCREW : TAPTIGHT BIND HD +	M3x6 NI
25	SSCW430050N	HEX NUT	M5 NI
26	SSCW540050N	WASHER : STAR	D5 NI
27	SSCW803006N	SCREW : P TIGHT BIND HD +	D3x6 NI
28	SSCW803008N	SCREW : P TIGHT BIND HD +	D3x8 NI
29	SSCW803014N	SCREW : P TIGHT BIND HD +	D3x14 NI

(Ref. No. in this Mechanical Parts List corresponds with the no. in Exploded View)

SCHEMATIC DIAGRAM

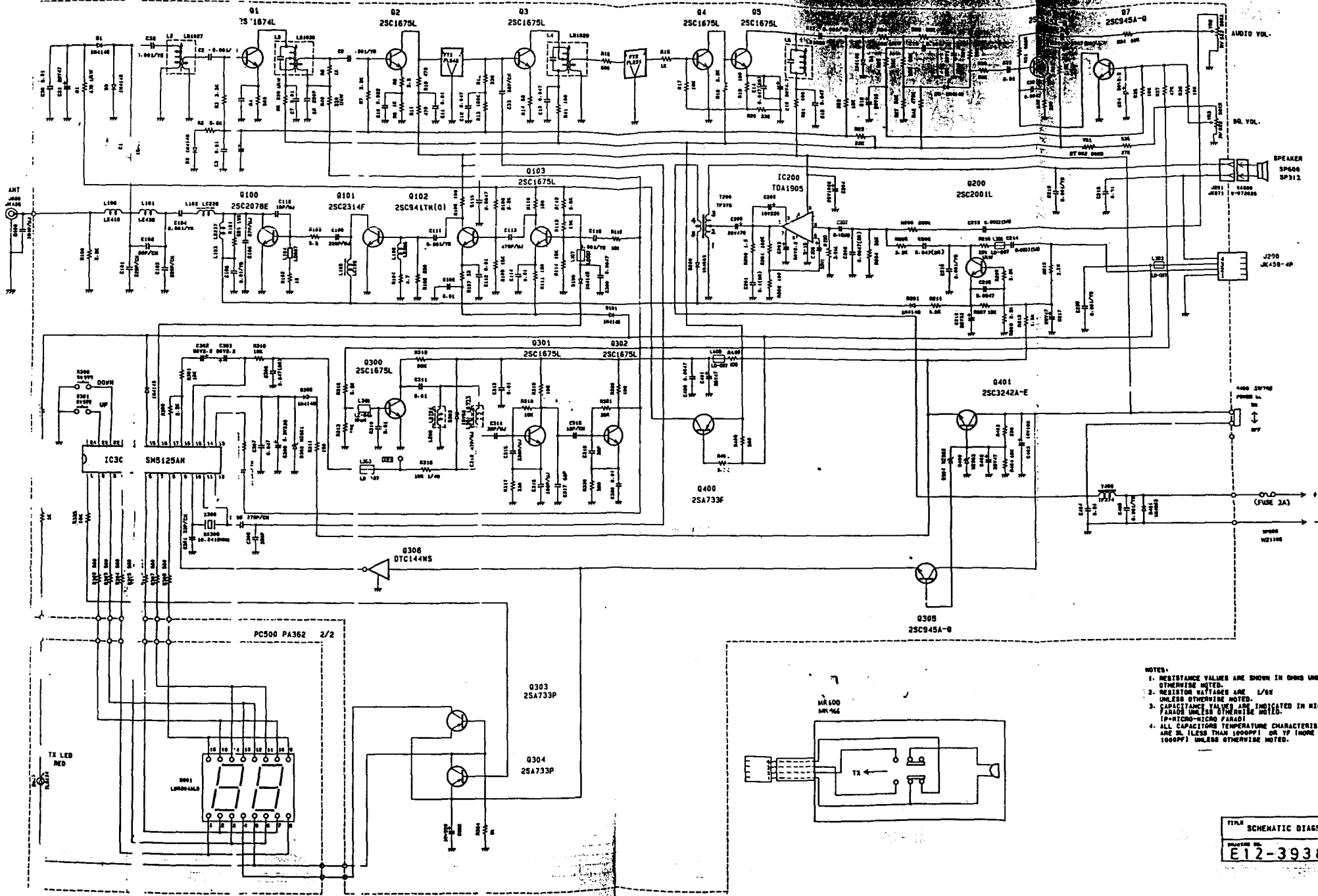

- NOTES:
1. RESISTANCE VALUES ARE SHOWN IN OHMS UNLESS OTHERWISE NOTED.
 2. RESISTOR VOLTAGES ARE UNLESS OTHERWISE NOTED. L/80
 3. CAPACITANCE VALUES ARE INDICATED IN MICRO FARADS UNLESS OTHERWISE NOTED. (P=PICO-MICRO FARAD)
 4. ALL CAPACITORS TEMPERATURE CHARACTERISTICS ARE 50 (LESS THAN 100PPM) OR 1P (MORE THAN 100PPM) UNLESS OTHERWISE NOTED.

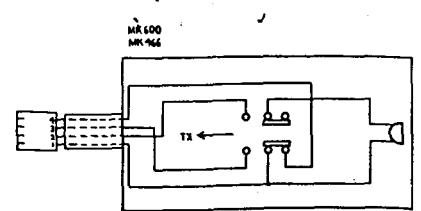

FILE SCHEMATIC DIAGRAM
 DRAWING NO. E12-3938

SCHEMATIC DIAGRAM

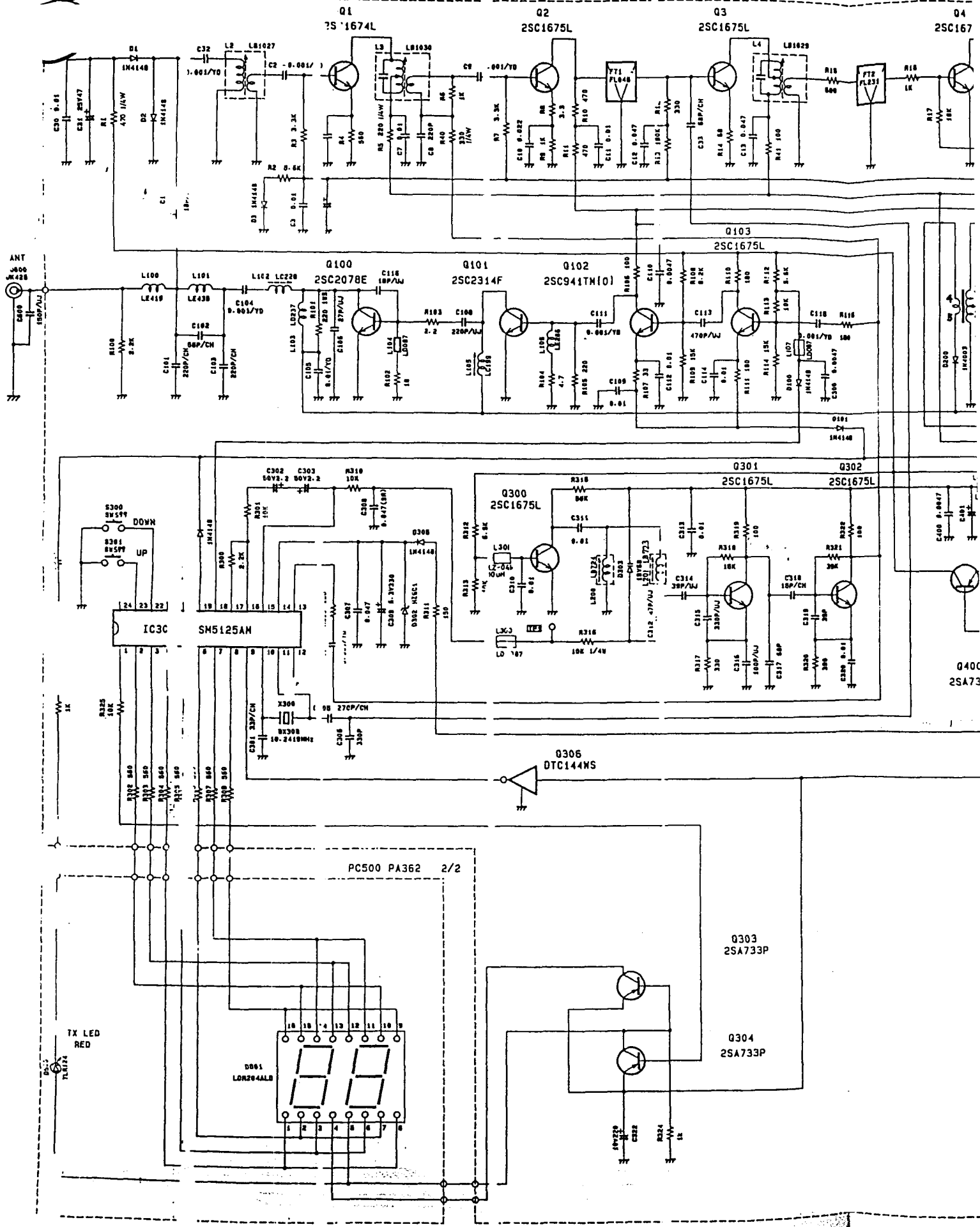

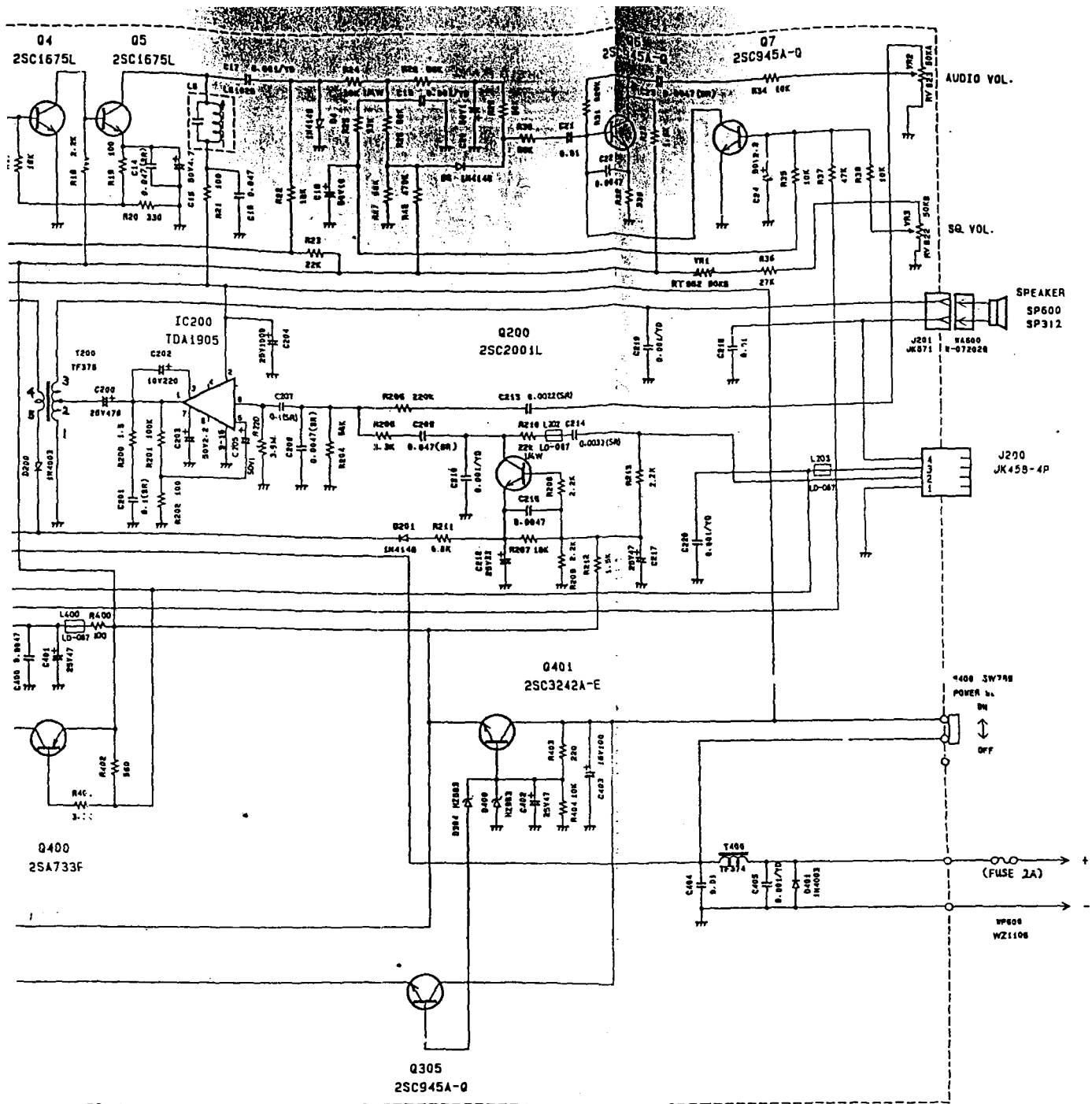

AUDIO VOL.
SQ VOL.
SPEAKER
SP600
SP312

J200
JK45B-4P

400 SW788
POWER ON
OFF

(FUSE 2A)

WZ1106

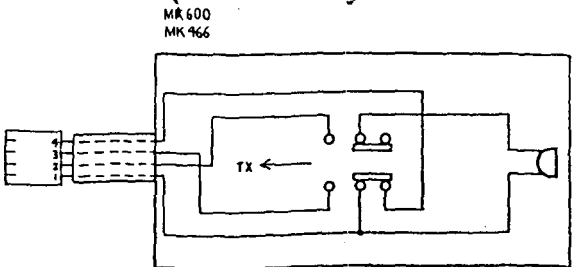

MK600
MK966

- NOTES:
1. RESISTANCE VALUES ARE SHOWN IN OHMS UNLESS OTHERWISE NOTED.
 2. RESISTOR WATTAGES ARE 1/6W UNLESS OTHERWISE NOTED.
 3. CAPACITANCE VALUES ARE INDICATED IN MICRO FARADS UNLESS OTHERWISE NOTED. (P=MICRO-MICRO FARAD)
 4. ALL CAPACITORS TEMPERATURE CHARACTERISTICS ARE 5L (LESS THAN 1000PF) OR YF (MORE THAN 1000PF) UNLESS OTHERWISE NOTED.

TITLE SCHEMATIC DIAGRAM
DRAWING NO. E12-3938

COMPONENT LAYOUT

PC001 PA-362AA - 1/27 (TOP VIEW)

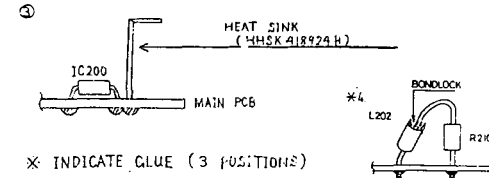
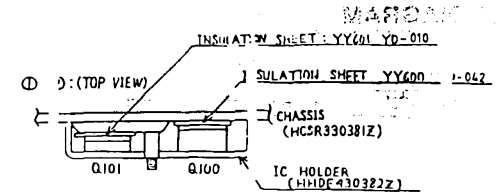
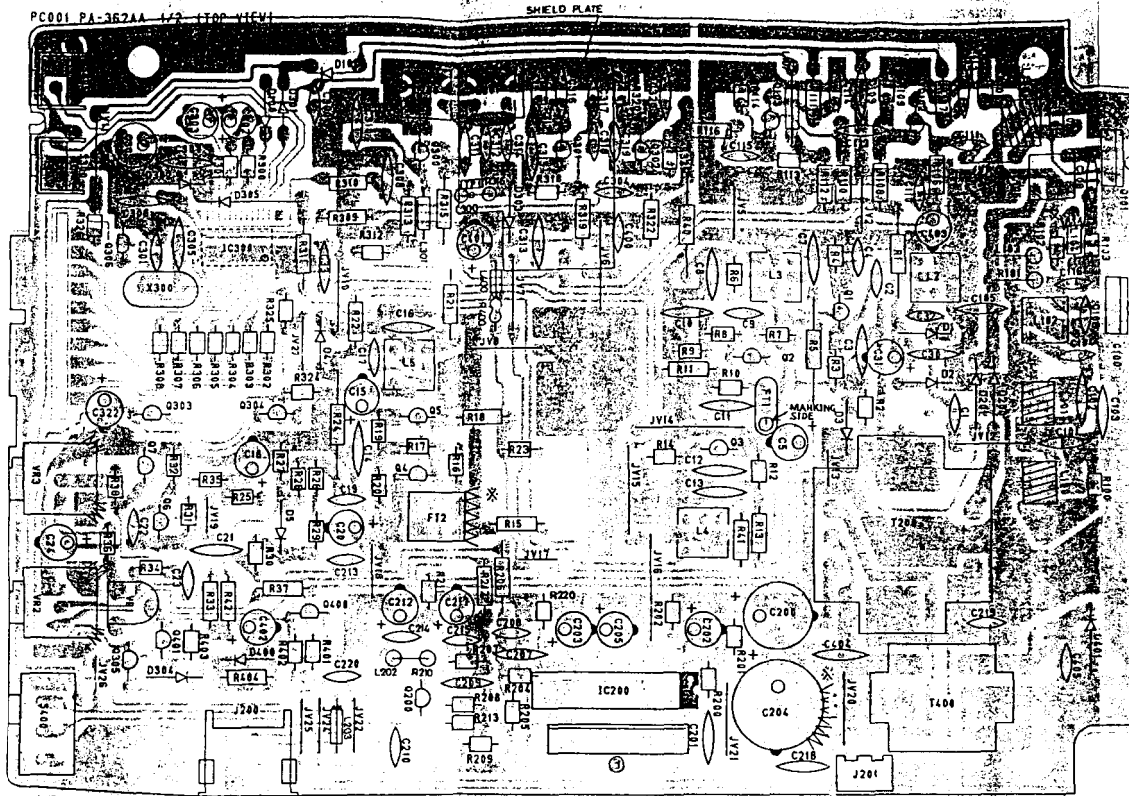

* INDICATE GLUE (3 POSITIONS)

////// - WITH BONDLOCK

/// - SOLDERING
* LOS MOUNTING REVERSE DO NOT FOLLOW PCB SILK PRINT.

D1	1N4148	L2	LB1027	JV1	7.5
D2	1N4148	L3	LB1030	JV2	7.5
D3	1N4148	L4	LB1025	JV5	7.5
D4	1N4148	L5	LB1030	JV6	12.5
D5	1N4148	L100	LE415 1 1/2T	JV7	12.5
D100	1N4148	L101	LE435 1 1/2T	JV8	12.5
D1	1N4148	L102	LC220	JV9	12.5
D100	1N4003	L103	LD251	JV1	12.5
D101	1N4148	L104	LD257	JV1	12.5
D102	1N4148	L105	LC100	JV1	12.5
D103	1N4148	L106	LE206 6 1/2T	JV1	12.5
D104	M2503	L200	LD24	JV1	12.5
D105	1N4148	L201	LD-307	JV1	12.5
D106	M2503	L202	LD-307	JV1	12.5
D107	M2503	L203	LD-307	JV1	12.5
D108	M2503	L107	LD-307	JV1	12.5
D109	M2503	L206	LD-307	JV1	12.5
D110	M2503	L207	LD-307	JV1	12.5
D111	M2503	L300	LD-307	JV1	12.5
D112	M2503	L301	LD-307	JV1	12.5
D113	M2503	L302	LD-307	JV1	12.5
D114	M2503	L303	LD-307	JV1	12.5
D115	M2503	L304	LD-307	JV1	12.5
D116	M2503	L305	LD-307	JV1	12.5
D117	M2503	L306	LD-307	JV1	12.5
D118	M2503	L307	LD-307	JV1	12.5
D119	M2503	L308	LD-307	JV1	12.5
D120	M2503	L309	LD-307	JV1	12.5
D121	M2503	L310	LD-307	JV1	12.5
D122	M2503	L311	LD-307	JV1	12.5
D123	M2503	L312	LD-307	JV1	12.5
D124	M2503	L313	LD-307	JV1	12.5
D125	M2503	L314	LD-307	JV1	12.5
D126	M2503	L315	LD-307	JV1	12.5
D127	M2503	L316	LD-307	JV1	12.5
D128	M2503	L317	LD-307	JV1	12.5
D129	M2503	L318	LD-307	JV1	12.5
D130	M2503	L319	LD-307	JV1	12.5
D131	M2503	L320	LD-307	JV1	12.5
D132	M2503	L321	LD-307	JV1	12.5
D133	M2503	L322	LD-307	JV1	12.5
D134	M2503	L323	LD-307	JV1	12.5
D135	M2503	L324	LD-307	JV1	12.5
D136	M2503	L325	LD-307	JV1	12.5
D137	M2503	L326	LD-307	JV1	12.5
D138	M2503	L327	LD-307	JV1	12.5
D139	M2503	L328	LD-307	JV1	12.5
D140	M2503	L329	LD-307	JV1	12.5
D141	M2503	L330	LD-307	JV1	12.5
D142	M2503	L331	LD-307	JV1	12.5
D143	M2503	L332	LD-307	JV1	12.5
D144	M2503	L333	LD-307	JV1	12.5
D145	M2503	L334	LD-307	JV1	12.5
D146	M2503	L335	LD-307	JV1	12.5
D147	M2503	L336	LD-307	JV1	12.5
D148	M2503	L337	LD-307	JV1	12.5
D149	M2503	L338	LD-307	JV1	12.5
D150	M2503	L339	LD-307	JV1	12.5
D151	M2503	L340	LD-307	JV1	12.5
D152	M2503	L341	LD-307	JV1	12.5
D153	M2503	L342	LD-307	JV1	12.5
D154	M2503	L343	LD-307	JV1	12.5
D155	M2503	L344	LD-307	JV1	12.5
D156	M2503	L345	LD-307	JV1	12.5
D157	M2503	L346	LD-307	JV1	12.5
D158	M2503	L347	LD-307	JV1	12.5
D159	M2503	L348	LD-307	JV1	12.5
D160	M2503	L349	LD-307	JV1	12.5
D161	M2503	L350	LD-307	JV1	12.5
D162	M2503	L351	LD-307	JV1	12.5
D163	M2503	L352	LD-307	JV1	12.5
D164	M2503	L353	LD-307	JV1	12.5
D165	M2503	L354	LD-307	JV1	12.5
D166	M2503	L355	LD-307	JV1	12.5
D167	M2503	L356	LD-307	JV1	12.5
D168	M2503	L357	LD-307	JV1	12.5
D169	M2503	L358	LD-307	JV1	12.5
D170	M2503	L359	LD-307	JV1	12.5
D171	M2503	L360	LD-307	JV1	12.5
D172	M2503	L361	LD-307	JV1	12.5
D173	M2503	L362	LD-307	JV1	12.5
D174	M2503	L363	LD-307	JV1	12.5
D175	M2503	L364	LD-307	JV1	12.5
D176	M2503	L365	LD-307	JV1	12.5
D177	M2503	L366	LD-307	JV1	12.5
D178	M2503	L367	LD-307	JV1	12.5
D179	M2503	L368	LD-307	JV1	12.5
D180	M2503	L369	LD-307	JV1	12.5
D181	M2503	L370	LD-307	JV1	12.5
D182	M2503	L371	LD-307	JV1	12.5
D183	M2503	L372	LD-307	JV1	12.5
D184	M2503	L373	LD-307	JV1	12.5
D185	M2503	L374	LD-307	JV1	12.5
D186	M2503	L375	LD-307	JV1	12.5
D187	M2503	L376	LD-307	JV1	12.5
D188	M2503	L377	LD-307	JV1	12.5
D189	M2503	L378	LD-307	JV1	12.5
D190	M2503	L379	LD-307	JV1	12.5
D191	M2503	L380	LD-307	JV1	12.5
D192	M2503	L381	LD-307	JV1	12.5
D193	M2503	L382	LD-307	JV1	12.5
D194	M2503	L383	LD-307	JV1	12.5
D195	M2503	L384	LD-307	JV1	12.5
D196	M2503	L385	LD-307	JV1	12.5
D197	M2503	L386	LD-307	JV1	12.5
D198	M2503	L387	LD-307	JV1	12.5
D199	M2503	L388	LD-307	JV1	12.5
D200	M2503	L389	LD-307	JV1	12.5
D201	M2503	L390	LD-307	JV1	12.5
D202	M2503	L391	LD-307	JV1	12.5
D203	M2503	L392	LD-307	JV1	12.5
D204	M2503	L393	LD-307	JV1	12.5
D205	M2503	L394	LD-307	JV1	12.5
D206	M2503	L395	LD-307	JV1	12.5
D207	M2503	L396	LD-307	JV1	12.5
D208	M2503	L397	LD-307	JV1	12.5
D209	M2503	L398	LD-307	JV1	12.5
D210	M2503	L399	LD-307	JV1	12.5
D211	M2503	L400	LD-307	JV1	12.5
D212	M2503	L401	LD-307	JV1	12.5
D213	M2503	L402	LD-307	JV1	12.5
D214	M2503	L403	LD-307	JV1	12.5
D215	M2503	L404	LD-307	JV1	12.5
D216	M2503	L405	LD-307	JV1	12.5
D217	M2503	L406	LD-307	JV1	12.5
D218	M2503	L407	LD-307	JV1	12.5
D219	M2503	L408	LD-307	JV1	12.5
D220	M2503	L409	LD-307	JV1	12.5
D221	M2503	L410	LD-307	JV1	12.5
D222	M2503	L411	LD-307	JV1	12.5
D223	M2503	L412	LD-307	JV1	12.5
D224	M2503	L413	LD-307	JV1	12.5
D225	M2503	L414	LD-307	JV1	12.5
D226	M2503	L415	LD-307	JV1	12.5
D227	M2503	L416	LD-307	JV1	12.5
D228	M2503	L417	LD-307	JV1	12.5
D229	M2503	L418	LD-307	JV1	12.5
D230	M2503	L419	LD-307	JV1	12.5
D231	M2503	L420	LD-307	JV1	12.5
D232	M2503	L421	LD-307	JV1	12.5
D233	M2503	L422	LD-307	JV1	12.5
D234	M2503	L423	LD-307	JV1	12.5
D235	M2503	L424	LD-307	JV1	12.5
D236	M2503	L425	LD-307	JV1	12.5
D237	M2503	L426	LD-307	JV1	12.5
D238	M2503	L427	LD-307	JV1	12.5
D239	M2503	L428	LD-307	JV1	12.5
D240	M2503	L429	LD-307	JV1	12.5
D241	M2503	L430	LD-307	JV1	12.5
D242	M2503	L431	LD-307	JV1	12.5
D243	M2503	L432	LD-307	JV1	12.5
D244	M2503	L433	LD-307	JV1	12.5
D245	M2503	L434	LD-307	JV1	12.5
D246	M2503	L435	LD-307	JV1	12.5
D247	M2503	L436	LD-307	JV1	12.5
D248	M2503	L437	LD-307	JV1	12.5
D249	M2503	L438	LD-307	JV1	12.5
D250	M2503	L439	LD-307	JV1	12.5
D251	M2503	L440	LD-307	JV1	12.5
D252	M2503	L441	LD-307	JV1	12.5
D253	M2503	L442	LD-307	JV1	12.5
D254	M2503	L443	LD-307	JV1	12.5
D255	M2503	L444	LD-307	JV1	12.5
D256	M2503	L445	LD-307	JV1	12.5
D257	M2503	L446	LD-307	JV1	12.5
D258	M2503	L447	LD-307	JV1	12.5
D259	M2503	L448	LD-307	JV1	12.5
D260	M2503	L449	LD-307	JV1	12.5
D261	M2503	L450	LD-307	JV1	12.5
D262	M2503	L451	LD-307	JV1	12.5
D263	M2503	L452	LD-307	JV1	12.5
D264	M2503	L453	LD-307	JV1	12.5
D265	M2503	L454	LD-307	JV1	12.5
D266	M2503	L455	LD-307	JV1	12.5
D267	M2503	L456	LD-307	JV1	12.5
D268	M2503	L457	LD-307	JV1	12.5
D269	M2503	L458	LD-307	JV1	12.5
D270	M2503	L459	LD-307	JV1	12.5
D271	M2503	L460	LD-307	JV1	12.5
D272	M2503	L461	LD-307	JV1	12.5
D273	M2503	L462	LD-307	JV1	12.5
D274	M2503	L463	LD-307	JV1	12.5
D275	M2503	L464	LD-307	JV1	12.5
D276	M2503	L465	LD-307	JV1	12.5
D277	M2503	L466	LD-307	JV1	12.5
D278	M2503	L467	LD-307	JV1	12.5
D279	M2503	L468	LD-307	JV1	12.5
D280	M2503	L469	LD-307	JV1	12.5
D281	M2503	L470	LD-307	JV1	12.5
D282	M2503	L471	LD-307	JV1	12.5
D283	M2503	L472	LD-307	JV1	12.5
D284	M2503	L473	LD-307	JV1	12.5
D285	M2503	L474	LD-307	JV1	12.5
D286	M2503	L475	LD-307	JV1	12.5
D287	M2503	L476	LD-307	JV1	12.5
D288	M2503	L477	LD-307	JV1	12.5
D289	M2503	L478	LD-307	JV1	12.5
D290	M2503	L479	LD-307	JV1	12.5
D291	M2503	L480	LD-307	JV1	12.5
D292	M2503	L481	LD-307	JV1	12.5
D293	M2503	L482	LD-307	JV1	12.5
D294	M2503	L483	LD-307	JV1	12.5
D295	M2503	L484	LD-307	JV1	12.5
D296	M2503	L485	LD-307	JV1	12.5
D297	M2503	L486	LD-307	JV1	12.5
D298	M2503	L487	LD-307	JV1	12.5
D299	M2503	L488	LD-307	JV1	12.5
D300	M2503	L489	LD-307	JV1	12.5
D301	M2503	L490	LD-307	JV1	12.5
D302	M2503	L			

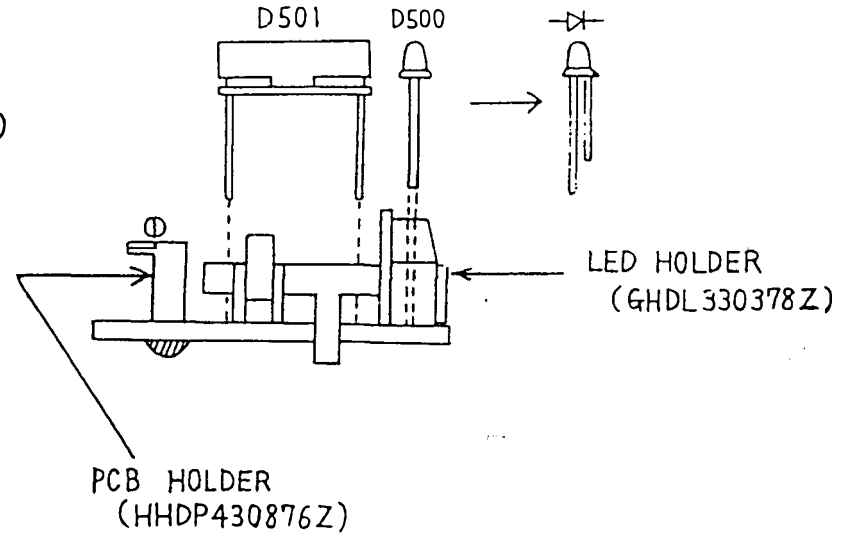
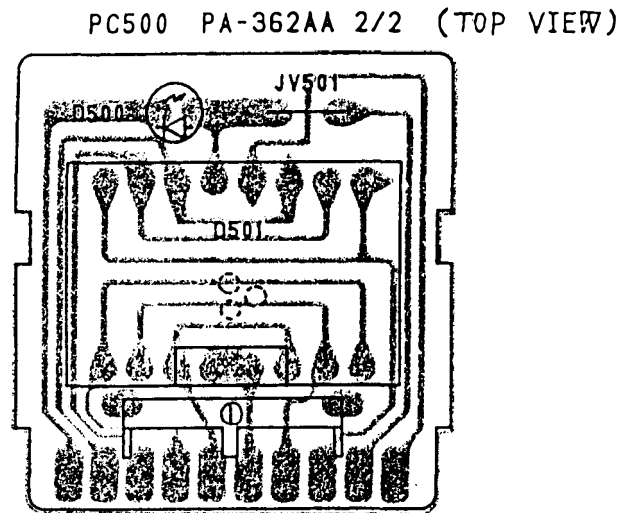

D500	TLR124	JV501	5.0
D501	LDR204ALD		

TITLE LED PCB
PARTS ASSEMBLY TOP VIEW
DRAWING NO.
E 24-10614

SHILD PLATE : HSDP430877Z

PC001 PA-362 1/2 (BOTTOM VIEW)

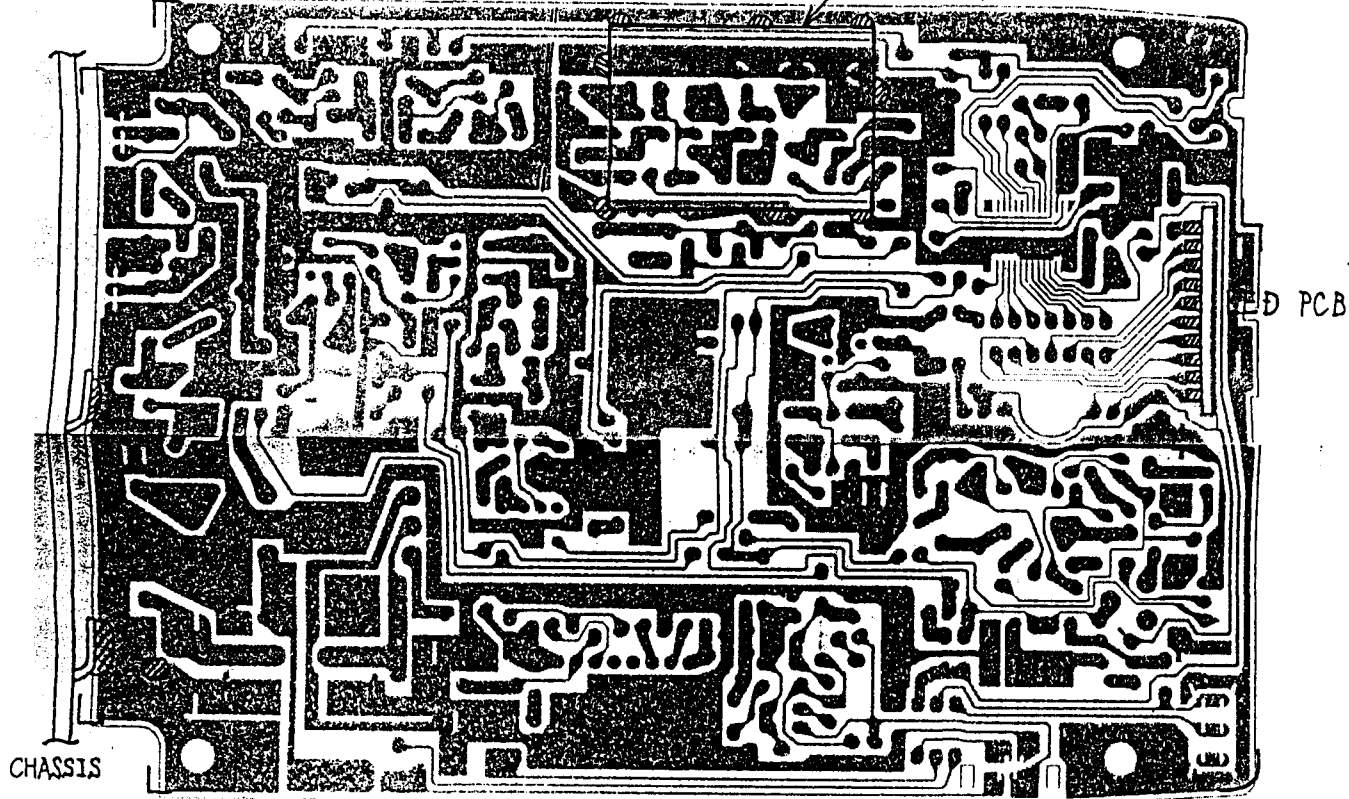

⊘ SOLDERING

// — PATTERN CUT

TITLE	MAIN PCB
PARTS ASSY BOTTOM	
DRAWING NO.	E 2 4 - 1 0 6 1 3

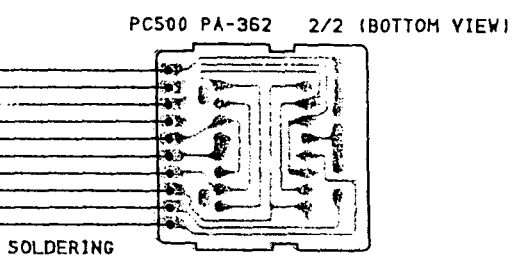
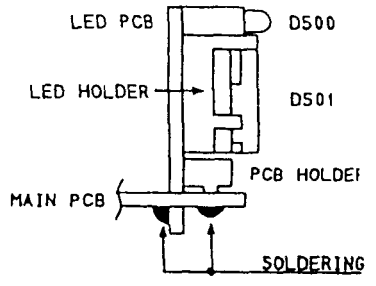
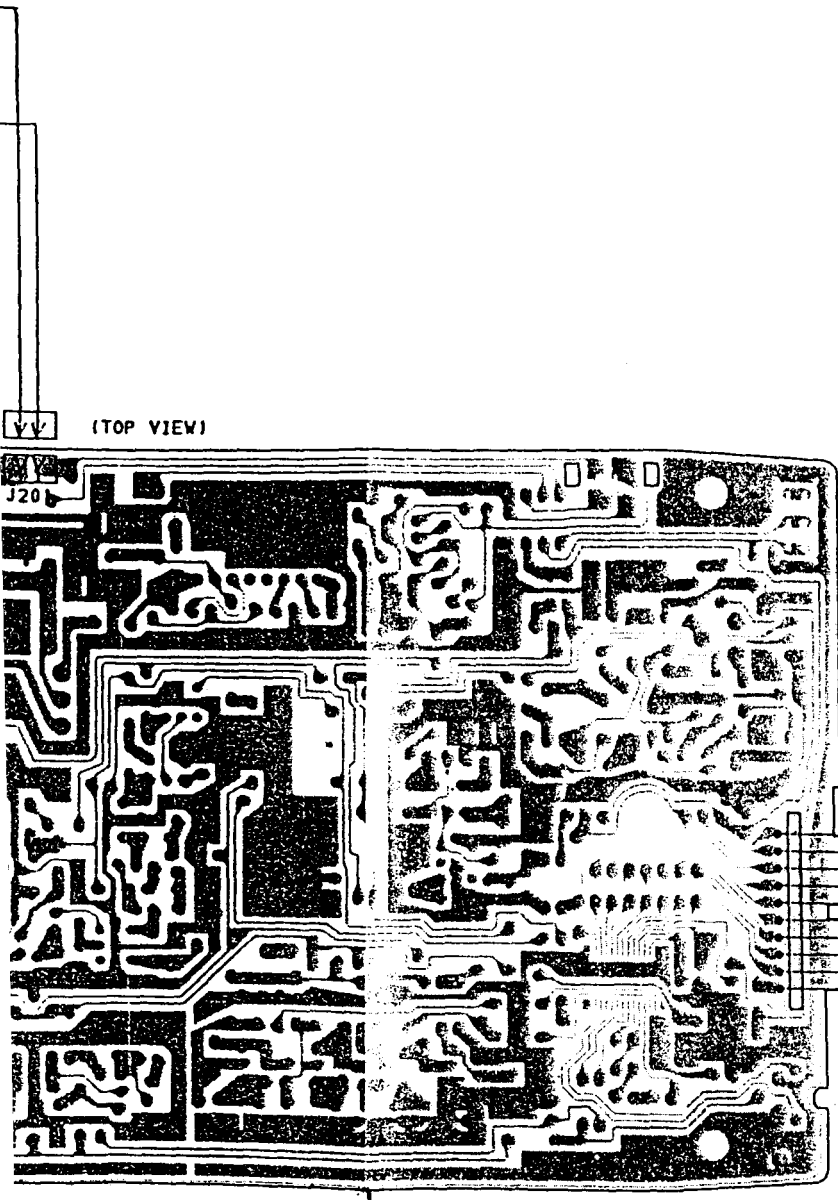

TITLE	WIRING DIAGRAM
DRAWING NO.	E33-3484

SPEAKER
SP600 SP-312

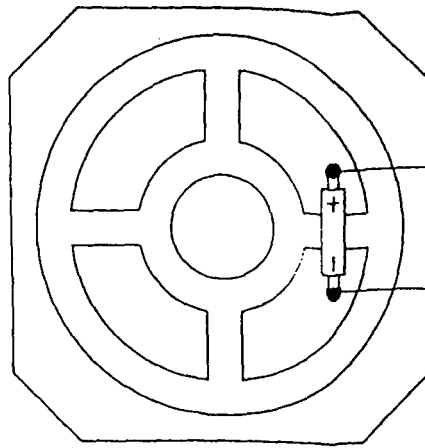

WA600 W-072028 GRY

GRY

PC001 PA-362 1/2 J20 (TOP VIEW)

DC CODE
WP600 WZ-1105

ANT. JACK
J600 JK-425

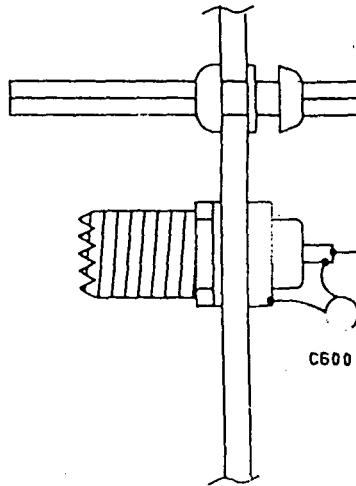

BLK

RED

W600 3-30-10 WHT

C600 150P/UJ

CHASSIS

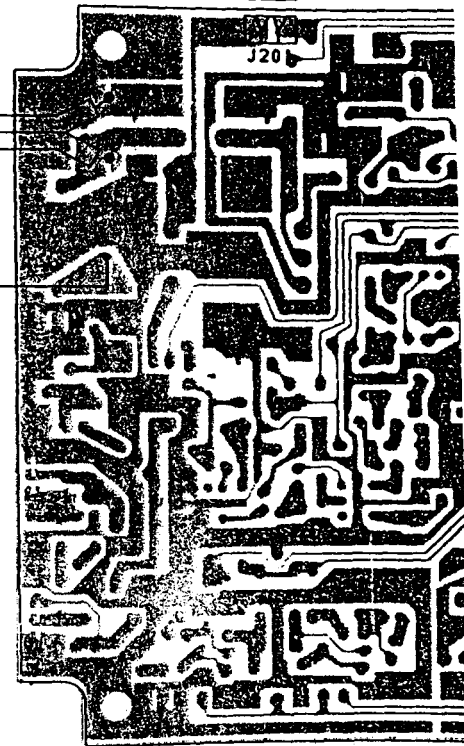

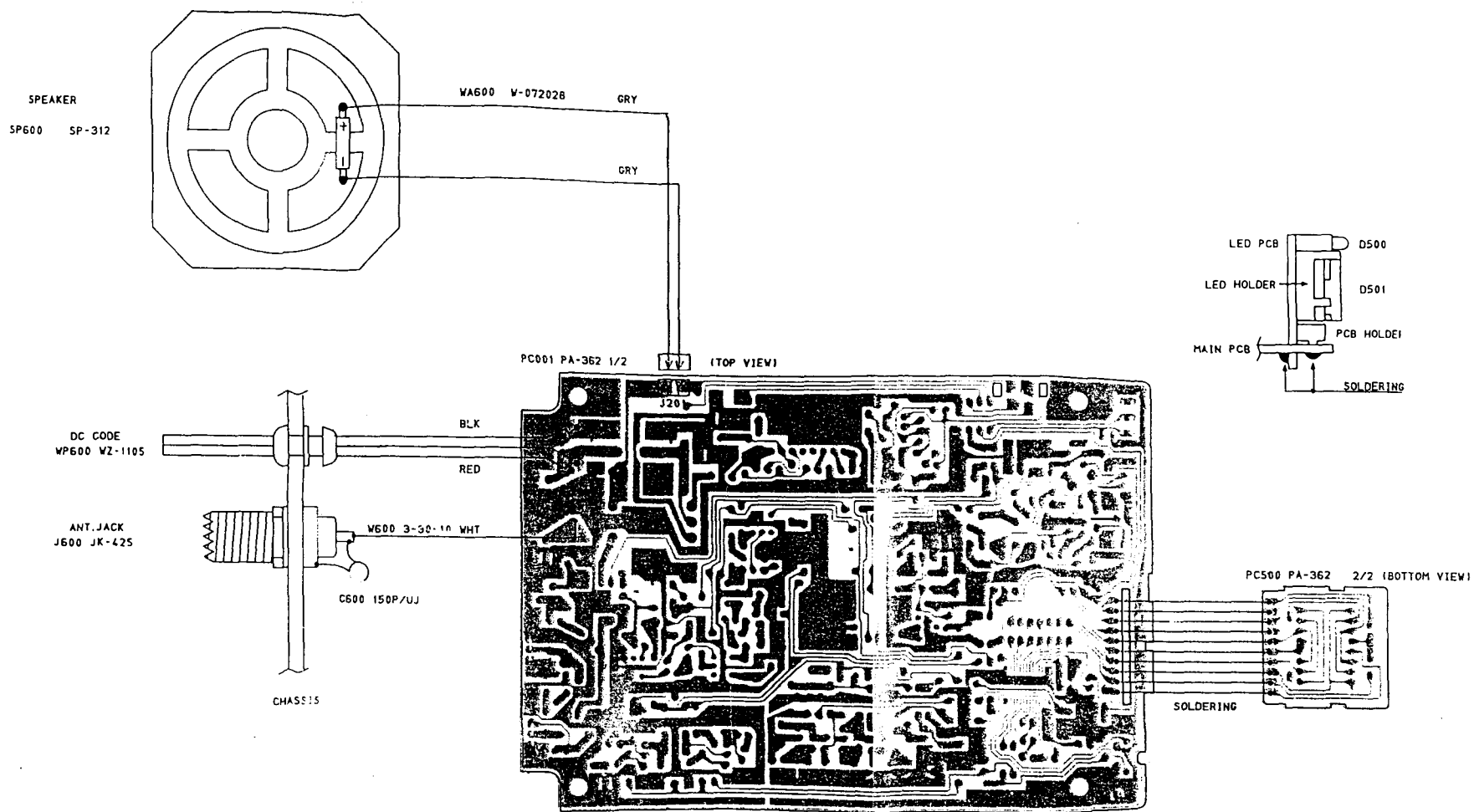

TITLE	VIRING DIAGRAM
DRAWING NO.	E33-3484

Groupe
PRESIDENT
E L E C T R O N I C S

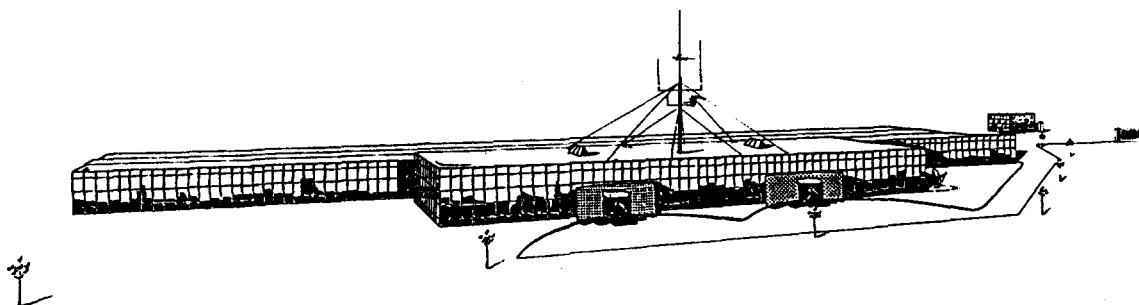

Siège Social / Head Office – France
Route de Sète – BP 100 – 34540 BALARUC
Tél. : 33.(0)4.67.46.27.27 – Fax : 33.(0)4.67.48.48.49
Site Internet : <http://www.president-electronics.com>
e-mail : groupe@president-electronics.com



VENTE EXCLUSIVE AUX DISTRIBUTEURS