

# **Service Manual**

**CB TRANSCEIVER**

**Model BENJAMIN**

**UT - 552B**

**uniden**  
CORPORATION

# TABLE OF CONTENTS

## I. SPECIFICATIONS

- A. GENERAL
- B. MEASUREMENT CONDITIONS
- C. TRANSMITTER
- D. RECEIVER
- E. GENERAL PERFORMANCE

## II. ALIGNMENT PROCEDURES

- A. CHECK OF FRONT PCB ASSEMBLY
- B. ADJUSTMENT POWER SUPPLY PCB ASSEMBLY
- C. PLL SECTION AND CARRIER OSCILLATOR SECTION ADJUSTMENT
- D. ALIGNMENT PROCEDURE OF TRANSMITTER
- E. ALIGNMENT PROCEDURE OF RECEIVER
- F. FREQUENCIES OF LOCAL OSCILLATORS AND IF STAGE IN RECEIVING STATE
- G. VOLTAGE CHART : TR & FED

## III. MEASUREMENT CONDITIONS

- A. SPECIFICATIONS
- B. HOWLING TEST STANDARD
- C. ALIGNMENT PROCEDURE

## IV. BLOCK DIAGRAM

## V. SCHEMATICS/PC BOARDS/WIRING DIAGRAMS

- A. EM2- : MAIN PCB (1/2) PARTS LIST ASSEMBLY TOP VIEW
- B. EM2-0123 : MAIN PCB (2/2) PARTS LIST
- C. EM2-0125 : FRONT CH SW PCB PARTS ASSEMBLY BOTTOM VIEW
- D. EM3-0126 : PWR SUPPLY PCB PARTS ASSEMBLY TOP VIEW
- E. EM3-0127 : ADDITIONAL PARTS ON BOTTOM
- F. EM4-0128 : SR PCB PARTS ASSEMBLY TOP VIEW
- G. EM4-0181 : FM PCB PARTS ASSEMBLY

# TABLE OF CONTENTS

H. ES2- : SCHEMATIC DIAGRAM (1/3)

I. ES3-0025 : SCHEMATIC DIAGRAM (2/3)

J. ES4-0043 : SCHEMATIC DIAGRAM (3/3)

K. EW2-0022 : WIRING DIAGRAM (1/2)

L. EW3-0032 : WIRING DIAGRAM (2/2)

VI. BILL OF MATERIAL : 17 P.S

## I. SPECIFICATIONS

### A. GENERAL

1. Channels : 40
2. Frequency Range : 26.965 MHz ~ 27.405 MHz
3. Semiconductors : 46 Transistors, 83 diodes, 8 I.C.s  
3 LEDS
4. Crystal : 2
5. Microphone : 500  $\Omega$ , Dynamic Type
6. Speaker : 16  $\Omega$ , 7 W Max
7. Antenna Connector : M - Type
8. Jacks & Connector : MIKE-4P METAL, EXT SP-3.5  $\emptyset$ .
9. Controls : Channel Selector, Mode Selector  
(AM-USB-LSB), FM Mode Selector,  
ON/OFF Power Switch & Volume & Squelch,  
Mike Gain & RF Gain, Clarifier,  
Hi Cut Switch, Noise Blanker-ANL Switch,  
Channel 19 Switch
10. Meter : RF Output Power/Signal Strength
11. Illuminations : Channel Number Indication (LED),  
TX Indication, RX Indication (LED)
12. Size : W : 14 3/8"  
H : 3 3/4"  
D : 8 7/8"
13. Weight : 3 Ibs. 2 oz.
14. Accessories : Microphone, Microphone Hanger

### B. MEASUREMENT CONDITIONS

1. Power Source : 220 V (AC)
2. Antenna Impedance : 50  $\Omega$
3. Test Temperature : 25° C
4. AM/FM Modulation Frequency : 1 kHz
5. SSB Modulation Frequency  
Transmit Two Tone : 500 Hz, 2.400 Hz
6. Mean Signal Input Level : 1.000  $\mu$  V
7. Standard Reference Modulation  
AM : 1 kHz, 30%
8. Standard Reference Modulation  
FM : 1 kHz,  $\pm$  1.5 kHz Dev.
9. Standard Audio Output : 0.5 W
10. Audio Frequency, SSB Receive : 1 kHz
11. Audio Output Load : 8  $\Omega$  Resistive



12. Measuring Channel : 19

13. Standard Method of Measurement : EIA RS-382 (1SS : 8 - 26 - 86)

C. TRANSMITTER

<u>ITEMS</u>	<u>MODE</u>	<u>UNIT</u>	<u>NOMINAL</u>	<u>LIMIT</u>		
1. Frequency Tolerance at 25°C (5 minutes after switch on)	AM	Hz	± 130	± 800		
	FM	Hz	± 130	± 800		
	SSB	Hz	± 130	± 800		
2. Carrier Power at No Modulation	AM	W	4	3.6 - 4.4		
	FM	W	4	3.6 - 4.4		
3. PEP Power, Two Tone, SSB	SSB	W <sub>pep</sub>	12	10.8 - 13.2		
4. Spurious & Harmonic Emission	AM	dB	- 65	- 60		
	FM	dB	- 65	- 60		
	SSB	dB	- 65	- 60		
5. Carrier Suppression	SSB	dB	- 50	- 40		
6. Current Drain (AC) at No Modulation	AM	mA	300	700		
	FM	mA	300	700		
	SSB	mA	150	300		
7. Current Drain (AC)	AM : MAX Mod.	AM	mA	300	700	
	FM : MAX Dev.	FM	mA	300	700	
	SSB : MAX W <sub>pep</sub> , Two Tone	SSB	mA	300	350	
8. Modulation Frequency Response (1kHz, 0 dB reference)	Lower at 450 Hz	AM	dB	- 4	- 8	
		FM	dB	- 10	- 10	
		SSB	dB	- 4	- 8	
	Upper at 2.5 kHz	AM	dB	- 4	- 8	
		FM	dB	- 5	- 10	
		SSB	dB	- 4	- 8	
	9. Microphone Sensitivity	AM : For 50% Mod.	AM	mV	1	2
		FM : For ± 1 kHz Dev.	FM	mV	1	2
		SSB : For 6 W <sub>pep</sub>	SSB	mV	1	2
10. AMC Range & ALC Range	AM : 50-100 % Mod.	AM	dB	50	40	

SSB : 9-13.2 Wpép	SSB	dB	50	40
11. Hum and Noise in Transmit				
AM : 50 % Mod.	AM	dB	50	40
FM : For $\pm 1.5$ kHz Dev.	FM	dB	40	30
12. Maximum Deviation	FM	kHz	2.7	3.5

D. RECEIVER

<u>ITEMS</u>	<u>MODE</u>	<u>UNIT</u>	<u>NOMINAL</u>	<u>LIMIT</u>
1. Max Sensitivity	AM	$\mu$ V	0.50	1.5
	SSB	$\mu$ V	0.25	0.50
2. Sensitivity				
AM : For 10 dB S/N	AM	$\mu$ V	1	2
FM : For 20 dB S/N	FM	$\mu$ V	1	2
SSB : For 10 dB S/N	SSB	$\mu$ V	0.25	0.50
3. AGC Figure of Merit 50 mV for 10 dB change in Audio Output	AM	dB	90	70
	SSB	dB	90	70
4. Overall Audio Fidelity (6 dB down, 1 kHz ref.)				
Upper Frequency	AM	Hz	2.000	1.500 ~ 3.000
	FM	Hz	2.500	1.500 ~ 4.000
	SSB	Hz	2.500	1.500 ~ 4.000
Lower Frequency	AM	Hz	250	200 ~ 500
	FM	Hz	250	100 ~ 500
	SSB	Hz	250	200 ~ 500
5. Distortion	AM	%	2	7
	FM	%	2	7
	SSB	%	2	7
6. S/N Ratio at 1 mV Input	AM	dB	35	25
	FM	dB	40	30
	SSB	dB	40	30
7. Squelch Sensitivity at Threshold	AM	$\mu$ W	1	2
	FM	$\mu$ W	1	2
	SSB	$\mu$ W	1	2
8. Squelch Sensitivity at Tight	AM	$\mu$ V	1.000	250 ~ 4.000

	FM	μV	1.000	250 ~ 4.000
	SSB	μV	1.000	250 ~ 4.000
9. S-Meter Sensitivity at "S-9"	AM	μV	100	40 ~ 250
	FM	μV	100	40 ~ 250
	SSB	μV	100	40 ~ 250
10. RF Gain Range	AM	dB	40	30
	FM	dB	40	30
	SSB	dB	40	30
11. Audio Output Power at Maximum	AM	W	3	2.5
	FM	W	3	2.5
	SSB	W	3	2.5
12. Audio Output Power at 10 % THD	AM	W	2.5	2
	FM	W	2.5	2
	SSB	W	2.5	2
13. Hi-Cut Effect at 2 kHz	AM	dB	- 6	- 3
	FM	dB	- 6	- 3
	SSB	dB	- 6	- 3
14. Clarifier Range	AM	Hz	± 1.500	± 600~ ± 2.500
	FM	Hz	± 1.500	± 600~ ± 2.500
	SSB	Hz	± 1.500	± 600~ ± 2.500
15. Noise Blanker Performance (EIA)	AM	dB	3	6
	FM	dB	3	6
	SSB	dB	3	6
16. ANL & NB Loss at 1μV Input	AM	dB	8	2 ~12
17. Current Drain at No Signal	AM	mA	100	200
	FM	mA	100	200
	SSB	mA	100	200
18. Current Drain				
at MAX Audio Output				
Power	AM	mA	150	300
	FM	mA	150	300
	SSB	mA	150	300
19. Dropout Voltage (AC)	AM	V	130	175
	FM	V	130	175
	SSB	V	130	175
20. Image Rejection Ratio	AM	dB	80	70
(for ± 910 kHz)	FM	dB	80	70
	SSB	dB	80	70

21. 1st IF Rejection Ratio (10.695 MHz)	AM	dB	80	70
	FM	dB	80	70
22. 2nd IF Rejection Ratio (455 kHz)	AM	dB	80	70
	FM	dB	80	70
	SSB	dB	80	70
23. Adjacent Rejection ( $\pm 10$ kHz)	AM	dB	60	50
	FM	dB	70	60
	SSB	dB	70	60

#### E. GENERAL PERFORMANCE

1. Output Protection : Shall meet for 5 minutes for all VSWR's (around the Smith Chart) of 20 : 1 without damage.
2. Output stability of all VSWR's (around the Smith Chart) of up to 5 : 1 under continuous operation of a duty cycle of 5 minutes transmitting, and 1 minute receiving.
3. Reverse Polarity Protection : Shall have reverse polarity protection and be operable with positive and negative grounding.
4. Standard Operating Temperature :  $-10^{\circ}\text{C} \sim +55^{\circ}\text{C}$
5. Storage Temperature :  $-30^{\circ}\text{C} \sim +70^{\circ}\text{C}$
6. Electrostatic Discharge Protection : All external case and component parts shall withstand the application of 15 kV ESD without causing failure or malfunction to the unit.

Test Conditions - Probe : 150pF with 500  $\Omega$  in series  
Temp. : 25° C

**II. ALIGNMENT PROCEDURES**

**A. CHECK OF FRONT PCB ASSEMBLY**

**1. Preparations**

Front PCB Check jig

**2. Conditions**

Supply Voltage : 110 V 60 Hz

Unless otherwise specified, S551, 552, 553 and 554 shall be switched OFF.

**3. Procedure**

STEP	ITEMS TO BE CHECKED
1	Rotate CH rotary switch and check if CH LED's in all channels from CH1 ~ CH40 are correctly displayed. Furthermore, check if there are no notable differences in luminance.
2	When S554 is switched "ON", check that "19" is displayed on CH LED.
3	Check that meter lamp, PL551 and 552 are always turned ON. Likewise, there should be no notable difference in luminance.
4	Check that TX LED and RX LED are properly lit. When the jig's PTT is ON, the TX LED should be ON and the RX and jig's PA LEDs should be OFF. When the jig's PTT is OFF, the TX, RX and PA LED indicators output will be reverse.
5	When S551 is switched ON, check that the jig's NB/ANL LED turns ON.
6	When S553 is switched ON, check that the jig's hi-cut LED turns OFF.

FRONT PANEL JIG

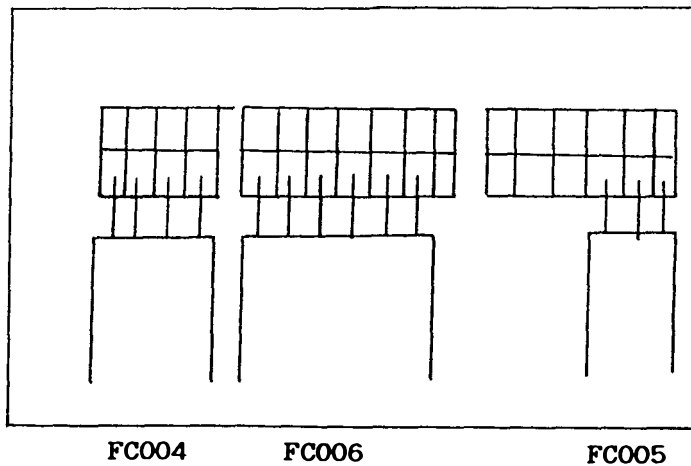

**B. ADJUSTMENT POWER SUPPLY PCB ASS'Y**

1. Preparations : Stabilized Power Supply (AC)  
DC Voltmeter
2. Conditions : Supply Voltage : 220V 60 Hz (AC)  
Probe Earth : TP10

**3. Adjustment**

STEP	MODE	MEASURING DEVICE CONNECTIONS	PT.S TO BE ADJ.	PROCEDURE
1	RX Standby	DC Voltmeter to JP32.	VR801	Connect WA501 to power source and switch power ON. Then adjust so that DC voltmeter indication is $13.8 \pm 0.1V$ .

VR801 is shown in Figure 4.

FIGURE 4

B801 PA-241

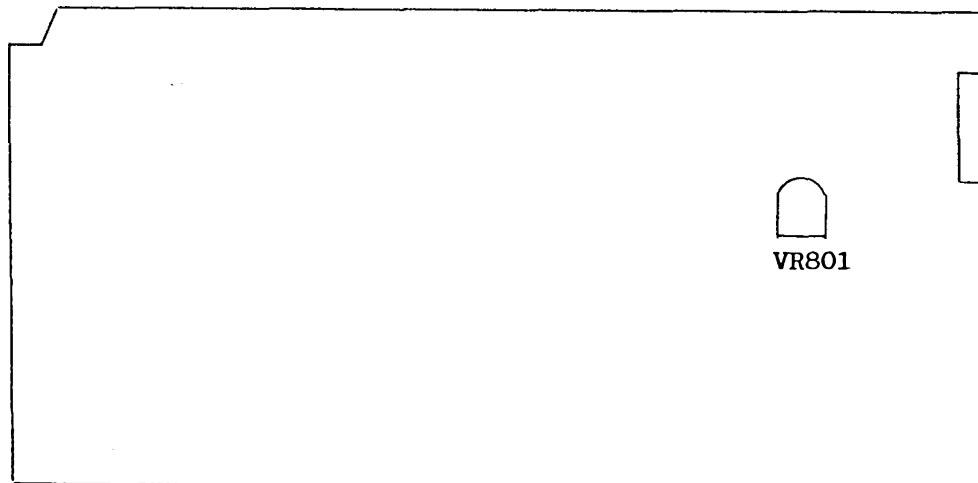

# Notice d'utilisation

## PRESIDENT BENJAMIN 120 CX.

(Réseivé à l'exportation, la modification en 120 cx entraine immédiatement l'annulation de la garantie et de l'homologation française !)

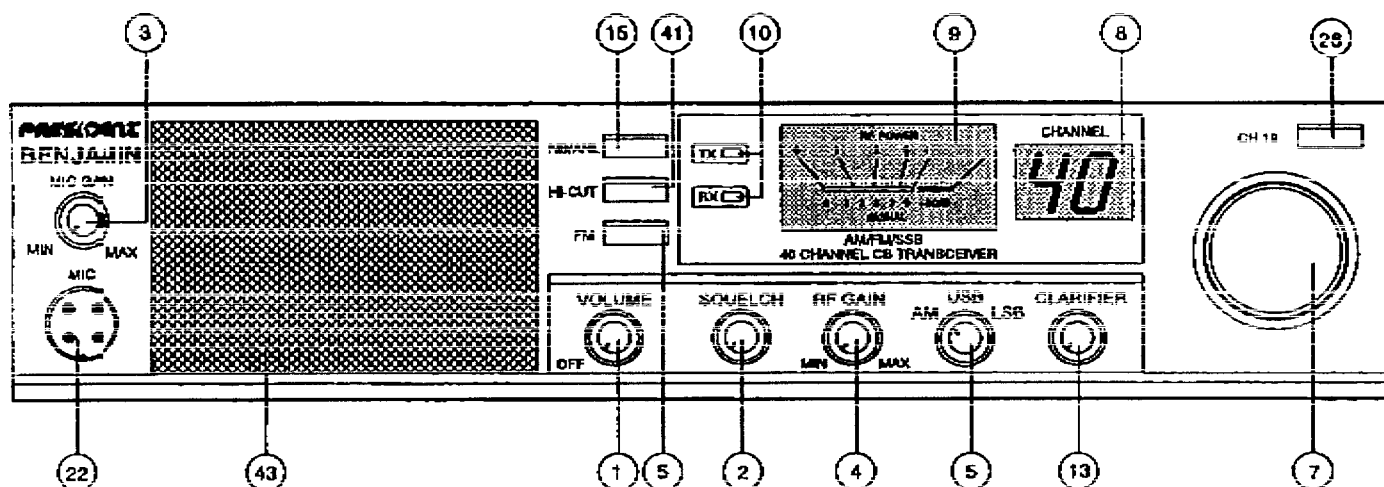

### PRESIDENT BENJAMIN

**Carac éristiques :** 120 canaux AM-FM-BLU. Puissance de sortie HF : 4 W AM/FM, 12 W BLU . Sensibilité 0,5  $\mu$ V (10 dB S/B). Sélectivité 60 dB. Alimentation sur secteur incorporée. Tension d'alimentation : 220 V-50 Hz (ATTENTION : Cet appareil ne doit pas être exposé à des projections d'eau ou éclaboussures).

**Commandes et fonctions :** Sélecteur de canaux. Réglage volume. Squelch. Gain micro, gain RF. Clarifier. Vu-mètre émission/récepton. Dimensions (mm) : Longueur 335. Hauteur : 95. Profondeur : 210.

- 1 Volume / Marche-Arrêt
- 2 Squelch
- 3 Gain micro
- 4 RF Gain
- 5 Commutateur AM/FM/BLU
- 7 Sélecteur de canaux
- 8 Afficheur
- 9 Vu-mètre
- 10 Led RX/TX
- 13 Clarifier
- 15 Commutateur LOW (NB/ANL)
- 22 Prise micro
- 26 Présélection canal 19
- 41 Commutateur HI (HI-CUT)
- 43 Haut-parleur

### MODIFICATION

Sur la platine 120 CX, vue de dessus, couper les Strapp qui relient R 21 et R 23 à la masse (Voir emplacements sur le schéma ci-dessous).

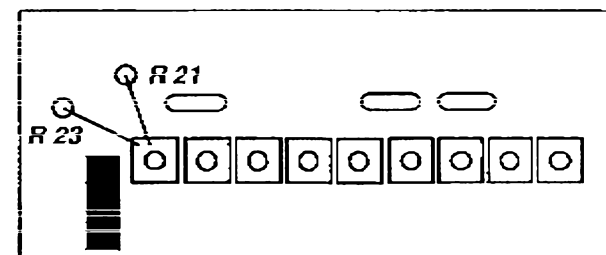

### UTILISATION

Touches	Position	Bande
NB/ANL HI/CUT	Non appuyé	MID
NB/ANL	Appuyé	LOW
HI/CUT	Appuyé	HI

# Notice d'utilisation

## PRESIDENT BENJAMIN 120 CX.

(Réservé à l'exportation, la modification en 120 cx entraîne immédiatement l'annulation de la garantie et de l'homologation française !)

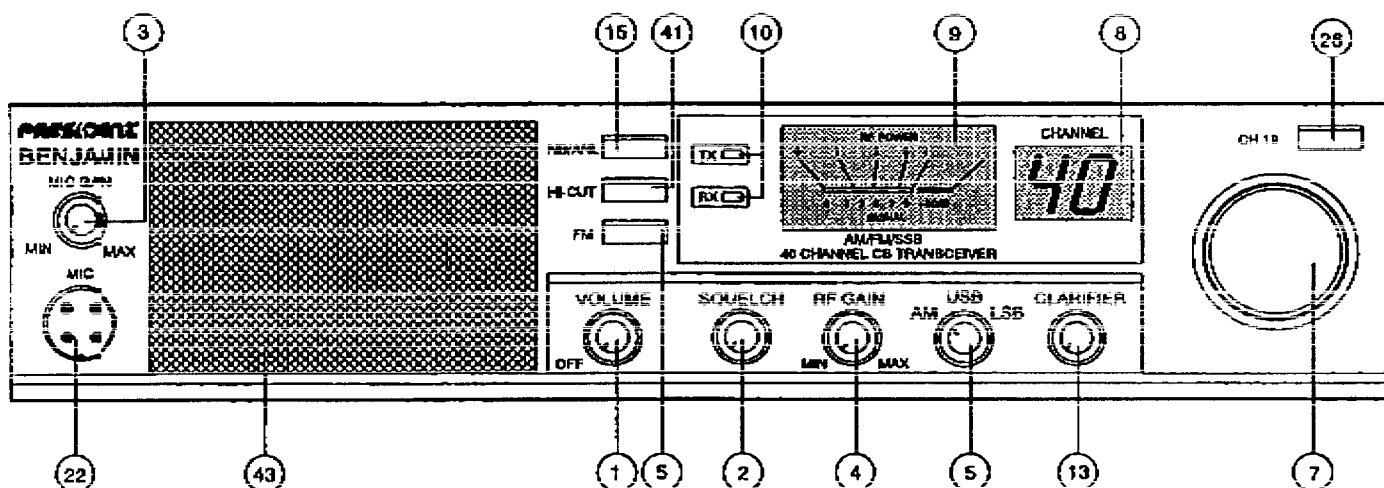

### PRESIDENT BENJAMIN

**Caractéristiques :** 120 canaux AM-FM-BLU. Puissance de sortie HF : 4 W AM/FM, 12 W BLU . Sensibilité 0,5  $\mu$ V (10 dB S/B). Sélectivité 60 dB. Alimentation sur secteur incorporée. Tension d'alimentation : 220 V-50 Hz (ATTENTION : Cet appareil ne doit pas être exposé à des projections d'eau ou éclaboussures).

**Commandes et fonctions :** Sélecteur de canaux. Réglage volume. Squelch. Gain micro, gain RF. Clarifier. Vu-mètre émission/récepteur. Dimensions (mm) : Longueur 335. Hauteur : 95. Profondeur : 210.

- 1 Volume / Marche-Arrêt
- 2 Squelch
- 3 Gain micro
- 4 RF Gain
- 5 Commutateur AM/FM/BLU
- 7 Sélecteur de canaux
- 8 Afficheur
- 9 Vu-mètre
- 10 Led RX/TX
- 13 Clarifier
- 15 Commutateur LOW (NB/ANL)
- 22 Prise micro
- 26 Présélection canal 19
- 41 Commutateur HI (HI-CUT)
- 43 Haut-parleur

### MODIFICATION

Sur la platine 120 CX, vue de dessus, couper les Strapp qui relient R 21 et R 23 à la masse (Voir emplacements sur le schéma ci-dessous).

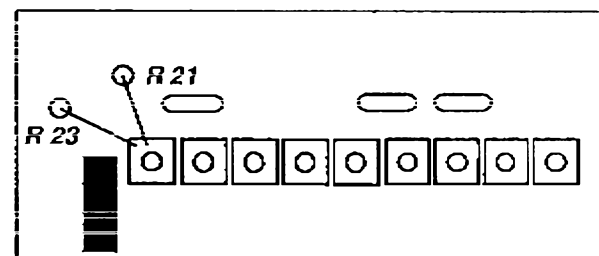

### UTILISATION

Touche	Position	Bande
NB/ANL HI/CUT	Non appuyé	MID
NB/ANL	Appuyé	LOW
HI/CUT	Appuyé	HI



# Notice d'utilisation

## PRESIDENT BENJAMIN 120 CX.

(Réservé à l'exportation, la modification en 120 cx entraine immédiatement l'annulation de la garantie et de l'homologation française !)

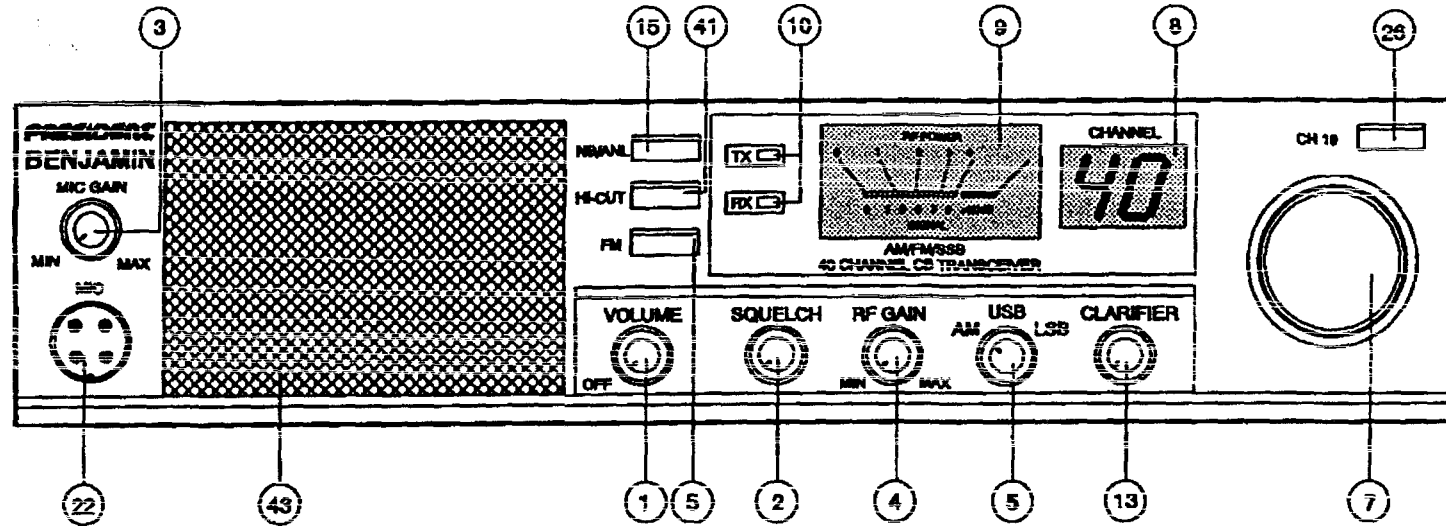

### MODIFICATION

Sur la platine 120 CX, vue de dessus, couper les Strapp de chaque côté de R24 (Voir emplacements sur le schéma ci-dessous).

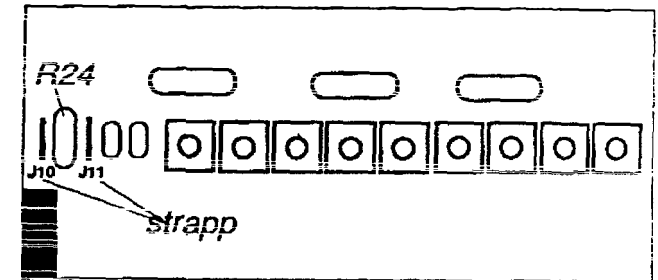

### PRESIDENT BENJAMIN

**Caractéristiques :** 120 canaux AM-FM-BLU. Puissance de sortie HF : 4 W AM/FM, 12 W BLU . Sensibilité 0,5  $\mu$ V (10 dB S/B). Sélectivité 60 dB. Alimentation sur secteur incorporée. Tension d'alimentation : 220 V-50 Hz (ATTENTION : Cet appareil ne doit pas être exposé à des projections d'eau ou éclaboussures).

**Commandes et fonctions :** Sélecteur de canaux. Réglage volume. Squelch. Gain micro, gain RF. Clarifier. Vu-mètre émission/réception. Dimensions (mm) : Longueur 335. Hauteur : 95. Profondeur : 210.

- 1 Volume / Marche-Arrêt
- 2 Squelch
- 3 Gain micro
- 4 RF Gain
- 5 Commutateur AM/FM/BLU
- 7 Sélecteur de canaux
- 8 Afficheur
- 9 Vu-mètre
- 10 Led RX/TX
- 13 Clarifier
- 15 Commutateur LOW (NB/ANL)
- 22 Prise micro
- 26 Présélection canal 19
- 41 Commutateur HI (HI-CUT)
- 43 Haut-parleur

### UTILISATION

Touches	Position	Bande
NB/ANL HI/CUT	Non appuyé	MID
NB/ANL	Appuyé	LOW
HI/CUT	Appuyé	HI

C. PLL SECTION AND CARRIER OSCILLATION SECTION ADJUSTMENT

Conditions

Supply Voltage (AC) : 220V 60 Hz      Probe Earth : TP10  
 Channel : 19 CH                      Clarifier : Center

STEP	MODE	MEASURING DEVICE CONNECTIONS	POINTS TO BE ADJ.	ADJUSTMENT PROCEDURE
1	RX AM 40 CH	Connect oscilloscope TP4.	L38	Adjust to MAX the oscilloscope indications.
2	DITTO	Connect DC voltmeter to TP2.	L13	Adjust so that DC voltmeter indication is w/in 4.5V $\pm$ 0.1V
3	RX AM 1 CH	Same as Step 2	-	Check that DC voltmeter indication is not less than 2V.
4	DITTO	Connect oscilloscope to TP3.	L14	Adjust to max the oscilloscope indication.
5	RX AM 19 CH	Connect freq. counter to TP3.	L15	Adjust so that frequency is within 16.490 MHz $\pm$ 20 Hz.
6	RX FM 19 CH	Same as Step 5	-	Check that frequency is within 16.490 MHz $\pm$ 40 Hz.
7	RX USB 19 CH	Same as Step 5	L16	Adjust so that frequency is within 16.4925 MHz $\pm$ 20 Hz.
8	RX LSB 19 CH	Same as Step 5	L17	Adjust so that frequency is within 16.4875 MHz $\pm$ 20 Hz.
9	TX LSB 19 CH	Same as Step 5	VR3	- do -
10	TX AM 19 CH	Connect freq. counter to TP9.	L18	Adjust so that frequency is within 10.695 MHz $\pm$ 20 Hz.
11	TX FM 19 CH	Same as Step 10	-	Check that frequency is within 10.695 MHz $\pm$ 50 Hz.
12	RX USB 19 CH	Connect freq. counter to TP5.	L19	Adjust so that frequency is within 10.6925 MHz $\pm$ 20 Hz.
13	RX LSB 19 CH	Same as Step 10	L20	Adjust so that frequency is within 10.6975 MHz $\pm$ 20 Hz.

Note : Apply paraffin lock to the portion in diagonal lines ( ● ) before adjustment. Then, apply paraffin lock to L13 screw core ( ● ) after adjustment.

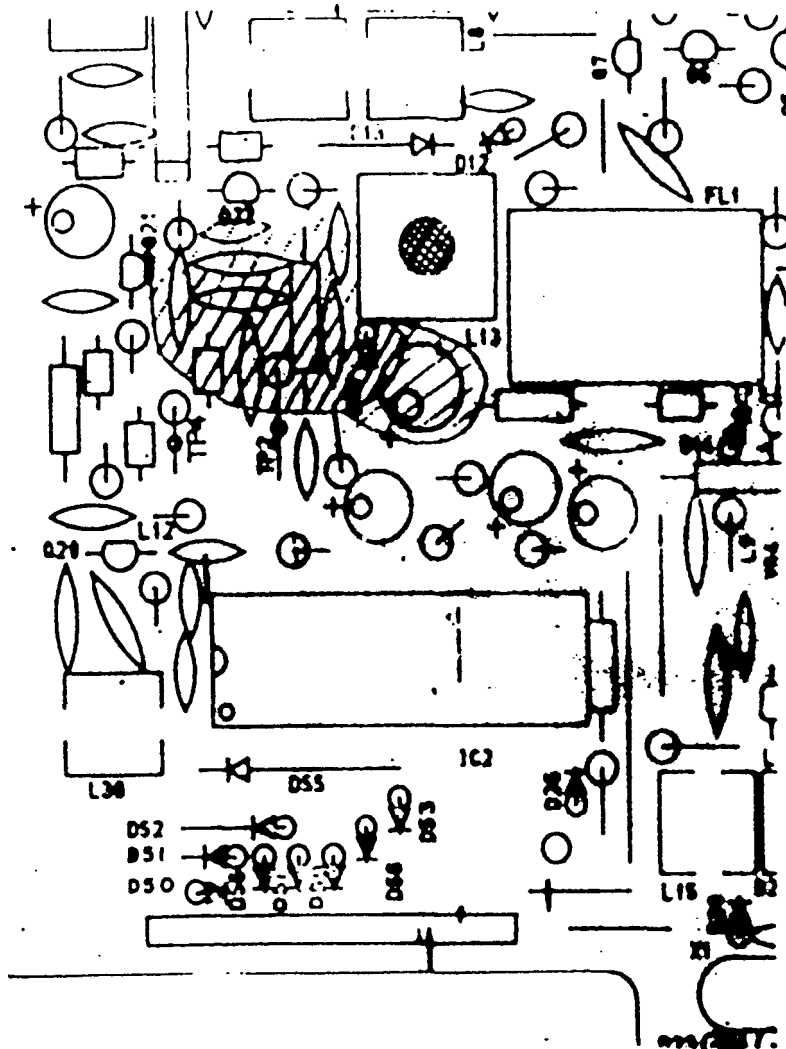

#### D. ALIGNMENT PROCEDURE OF TRANSMITTER

##### Conditions

Supply Voltage (AC) : 220V 60 Hz  
 Probe Earth : TP 10  
 Load Impedance : 50  $\Omega$   
 Mod. Freq. : AM 1 KHz, FM 1 KHz  
                   SSB 500 Hz & 2.400 Hz  
 Channel : 19 CH  
 Mic Gain : MAX

STEP	MODE	MEASURING DEVICE CONNECTIONS	POINTS TO BE ADJ.	ADJUSTMENT PROCEDURE
1	USB 19 CH NO MOD	Disconnect B002 (PB-100) and connect DC ammeter to TP8(+) & TP7(-)	VR 9	Adjust so that DC ampere-meter indication is 65 mA. If this is not met, set VR9 to MAX.
2	DITTO	Connect DC ammeter to TP8(+) & TP6(-)	VR8	Adjust so that DC ampere-meter indication is 30 mA.
3	USB 19 CH MOD IN	Remove DC ammeter & connect B002 (PB-100). Connect Powermeter, RF VTVM and oscilloscope to ANT JACK. (J501)	L34, 35, 36, 37, & 14	Adjust to MAX the RF voltmeter indication. However, adjust MOD input so that output does not exceed 20V. (Must be repeated twice).
4	USB MOD IN	Same as Step 3	L36	Alternately switch CH1 & CH40 & adjust the power deviation at that instant to MIN. However, adjust MOD input so that RF output does not exceed 20 V
5	AM 19 CH	Same as Step 3	L26	Adjust Mod input so that MOD is about 90 % (negative) and adjust to MAX the RF voltmeter indication. However, if 90 % is not met, rotate VR5.
6	USB 19 CH 30 mV MOD IN	Same as Step 3	VR6	Adjust to 24.5V the RF voltmeter indication.

STEP	MODE	MEASURING DEVICE CONNECTIONS	POINTS TO BE ADJ.	ADJUSTMENT PROCEDURE
7	USB 19 CH NO MODE	Same as Step 3	VR 4	Adjust so that the carrier leak is MIN and nearly equal in USB and LSB.
8	AM 19 CH NO MODE	Same as Step 3	VR10	Adjust to 4.0 W the power meter indication.
9	AM 19 CH NO MOD	Same as Step 3	VR 7	Adjust to RF power "4" the meter indication of the unit.
10	AM 19 CH 30 mV MOD IN	Same as Step 3	VR 5	Adjust modulation to 90 % (-).
11	FM 1 CH 30 mV MOD IN.	Connect FM Linear Detector	VR601	Adjust Deviation to 2.7 KHz Dev.

After adjustment apply parrafin lock on L26.

E. ALIGNMENT PROCEDURE OF RECEIVER

Conditions

Supply voltage (AC) : 220V 60Hz SSG Freq. : 27.185 MHz  
 Channel : 19 CH (19 CH)  
 Output Impedance : 8  $\Omega$  SSG Mod. Signal : 1.000 Hz 30% MOD.  
 Standard Output : 500 mW : 1.5 KHz DEV. FM  
 Ant. Impedance : 50 OHMS Probe Earth : TP10. (FM TP 13)

Unless otherwise specified, switches, volumes and etc. shall be set as follows :

NB/ANL SW : OFF RF Gain : MAX  
 Clarifier : Center Squelch : MIN  
 Volume : MAX HI Cut SW : OFF

The dB values below are all direct readings from SSG attenuator.

STEP	MODE	POINTS TO BE ADJ.	ADJUSTMENT PROCEDURE
1	RX AM 19 CH	L 5	Sink the core up to the deepest part
2	RX AM 19 CH	L3, 4, 6, 7, 8, 10, 11	Adjust each coil to peak. However, suitably reduce the SSG Att. so that the standard output will not be exceeded at all times.
3	RX AM 1 CH/ 40 CH	L 5	Adjust to peak at CH1. Next, alternately switch CH1 & CH40 and adjust so that sensitivity deviation is within 1 dB.
4	RX USB 20 CH ANL/NB SW ON	L 2	Connect oscilloscope to TP1 (R15 lid) & sink the core up to the deepest part of L2. Then adjust coil to 1st DC peak level as seen from the oscilloscope. SSG Att. shall be set at 20 dB. After adjustment, turn OFF ANL/NB SW.
5	RX AM 19 CH	VR 2	Adjust so that squelch opens at SSG output of 66dB $\pm$ 2dB.
6	RX AM 19 CH	VR 1	Set SSG output to NO MOD 46 dB. Adjust to signal "9" the meter indication of the unit
7	RX FM 19 CH	L602	Connect RF oscilloscope to TP12 (R633) Adjust to MAX the oscilloscope RF level.
8	SAME AS 7	L601	SSG output to 1.5 KHz Dev. MOD 66dB. Adjust to MAX WAVE at the nearly standard output.

PB-122 MAIN (TOP VIEW)

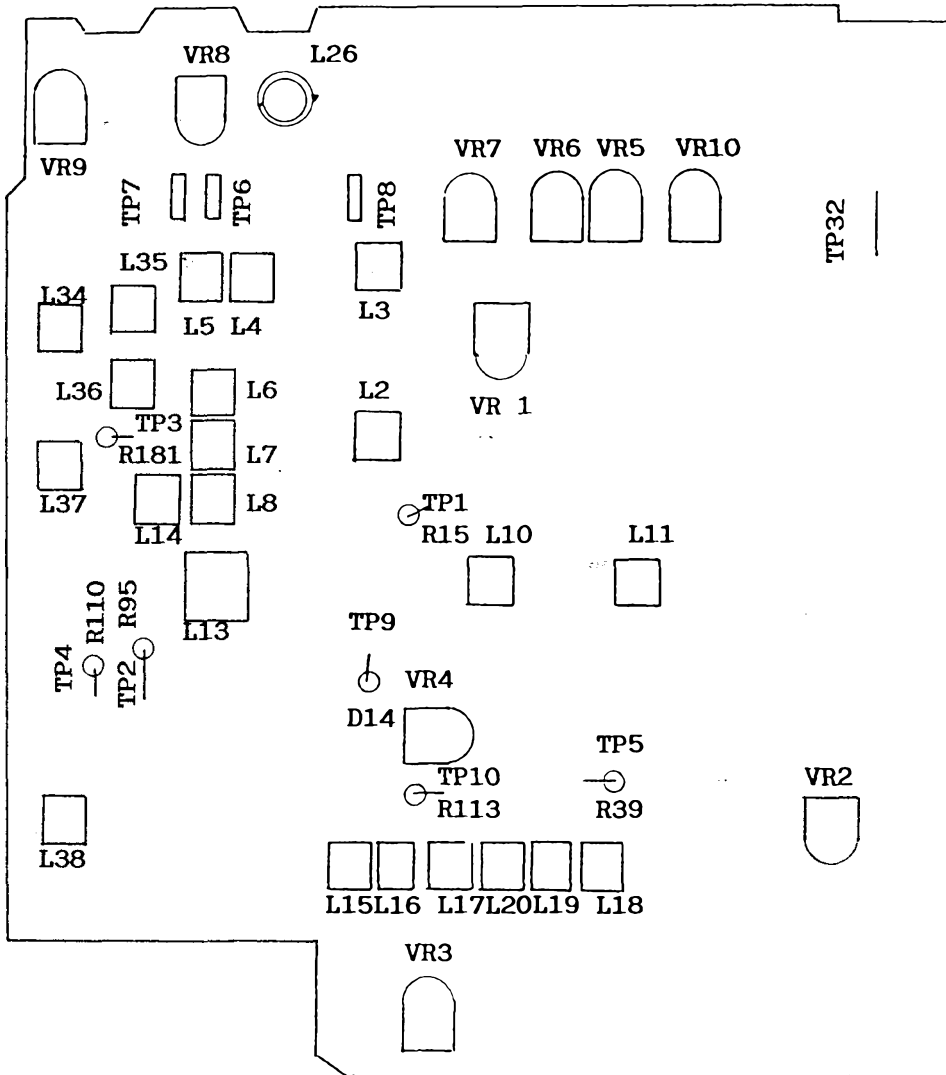

PB-189 : FM (TOP VIEW)

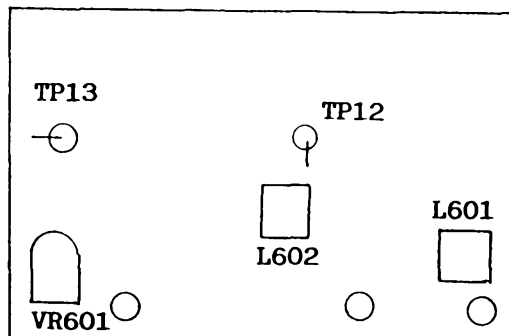

F. FREQUENCIES OF LOCAL OSCILLATORS AND IF STAGE IN RECEIVING STATE

CHANNEL NO.	RECEPTION FREQUENCIES (MHz)	DIVIDE RATIO (N)	LOCAL FM AM MODE	OSCILLATOR (MHz) USB MODE	FREQUENCIES LSB MODE	I.F. FREQUENCY (MHz)
1	26.965	91	16.270	16.2725	16.2675	10.695
2	26.975	92	16.280	16.2825	16.2775	10.695
3	26.985	93	16.290	16.2925	16.2875	10.695
4	27.005	95	16.310	16.3125	16.3075	10.695
5	27.015	96	16.320	16.3225	16.3175	10.695
6	27.025	97	16.330	16.3325	16.3275	10.695
7	27.035	98	16.340	16.3425	16.3375	10.695
8	27.055	100	16.360	16.3625	16.3575	10.695
9	27.065	101	16.370	16.3725	16.3675	10.695
10	27.075	102	16.380	16.3825	16.3775	10.695
11	27.085	103	16.390	16.3925	16.3875	10.695
12	27.105	105	16.410	16.4125	16.4075	10.695
13	27.115	106	16.420	16.4225	16.4175	10.695
14	27.125	107	16.430	16.4325	16.4275	10.695
15	27.135	108	16.440	16.4425	16.4375	10.695
16	27.155	110	16.460	16.4625	16.4575	10.695
17	27.165	111	16.470	16.4725	16.4675	10.695
18	27.175	112	16.480	16.4825	16.4775	10.695
19	27.185	113	16.490	16.4925	16.4875	10.695
20	27.205	115	16.510	16.5125	16.5075	10.695
21	27.215	116	16.520	16.5225	16.5175	10.695
22	27.225	117	16.530	16.5325	16.5275	10.695
23	27.255	120	16.560	16.5625	16.5575	10.695
24	27.235	118	16.540	16.5425	16.5375	10.695
25	27.245	119	16.550	16.5525	16.5475	10.695
26	27.265	121	16.570	16.5725	16.5675	10.695
27	27.275	122	16.580	16.5825	16.5775	10.695
28	27.285	123	16.590	16.5925	16.5875	10.695
29	27.295	124	16.600	16.6025	16.5975	10.695
30	27.305	125	16.610	16.6125	16.6075	10.695
31	27.315	126	16.620	16.6225	16.6175	10.695
32	27.325	127	16.630	16.6325	16.6275	10.695
33	27.335	128	16.640	16.6425	16.6375	10.695
34	27.345	129	16.650	16.6525	16.6475	10.695
35	27.355	130	16.660	16.6625	16.6575	10.695
36	27.365	131	16.670	16.6725	16.6675	10.695
37	27.375	132	16.680	16.6825	16.6775	10.695
38	27.385	133	16.690	16.6925	16.6875	10.695
39	27.395	134	16.700	16.7025	16.6975	10.695
40	27.405	135	16.710	16.7125	16.7075	10.695



SYMB NO.	PIN NO.	RX/TX	VOLTAGE
IC 1	1	RX	0.2
	2		0.1
	3		0.1
	4		0
	5		1.2
	6		1.5
	7		0
	8		8.0
IC 2	1	RX TX	5.1
	2		0
	3		0
	4		5.1
	5		5.1
	6		0
	7		5.1
	8		-
	9		-
	10		2.0
	11		5.1
	12		2.5
	13		2.5
	14		-
15		5.2	
16		5.1	
17		1.6	
18		1.6	
19		3.9	
20		-	
21		0	
22		2.4	
IC 3	1	RX TX	0
	2		3.3
	3		3.2
	4		0
	5		5.8
	6		7.3
	7		6.6
IC 4	1	RX TX	3.6 8.0
	2		0

SYMB NO.	PIN NO.	RX/TX	VOLTAGE
IC 5	3		13.7
	1	RX	0.1
	2		1.9
	3		1.3
	4		0
	5		0
	6		7.0
	7		12.7
IC 6	8		13.7
	1	TX	7.6
	2		-
	3		-
	4		-
	5		0
	6		2.6
	7		4.2
	8		4.2
	9		7.4
	1	TX	4
	2		3.9
	3		3.9
	4		0
	5		3.9
	6		3.9
7		3.9	
8		7.8	
IC601	1	RX	7.7
	2		7.1
	3		7.4
	4		7.7
	5		1
	6		1
	7		1
	8		7.8
IC602	9		3.3
	10		0
	11		7.2
	12		0
	13		7.1
	14		0
	15		0
	16		0

III. VOLTAGE CHART : TR & FED

SYMBOL NO.	*	RX TX	BASE GATE	COLLECTION DRAIN	EMITTER SOURCE
Q1		RX NB ON	1.5	6.9	0.8
Q2		↓	0.7	2.6	0
Q3			2.6	6.8	1.9
Q4			0.1	7.2	0.8
Q5			0.1	6.6	0
Q6			6.6	0	7.2
Q7		↓	0	0	0
Q8		RX	0.4	8.0	0
Q9		RX	0.7	0	0
Q10		SSB RX	0.7	0	0
Q11		↓	1.6	4.7	0.9
Q12	FM	RX	0	3.6	0
		TX	0.7	0	0
Q13		RX	2.1	6.8	1.4
Q14		↓	0	6.6	3.4
Q15			1.4	7.9	0.7
Q16			0.7	3.4	0
Q17			3.4	6.2	2.7
Q18		↓	2.7	6.4	1.9
Q19		RX AM	0.7	0	0
		SSB	0	2.9	0
Q20		RX	1.3	4.7	0.8
		TX	1.3	4.7	0.8
Q21		↓	2.9	6.8	2.5
Q22			0.7	4.3	0
			4.2	5.6	3.5
Q23		↓	4.2	5.6	3.5
Q24		RX SSB	2.8	6.9	2.1
		TX	2.8	6.7	2.1
Q25		TX	1.7	3.4	1.1
Q26		↓	0.9	1.7	0.3
Q27		RX	0.7	0	0
		TX	0	0	0
Q28		RX	7.8	6.6	8.0
		TX	7.8	0	8.0
Q29		TX	1.0	7.8	1.4
Q30		↓	2.5	4.5	1.5
Q31		RX	7.8	8.0	7.2
		TX	0	8.0	0
Q34		TX	0	7.8	1.4
		SSB	0		
Q35		TX AM	1.2	5.7	0.5
		SSB	1.2	7.8	0.5
Q36		↓	6.2	12.2	5.7
			12.6	13.2	13.1
Q37			12.8	5.7	12.3
			13	13.7	13.2

SYMBOL NO.	*	RX TX	BASE GATE	COLLECTION DRAIN	EMITTER SOURCE
Q38			0.3	12.9	0
			0.7	0	0
Q501			0.5	5.6	0
			0.6	13.7	0
Q502			0.6	5.5	0
			0.7	13.7	0
Q503			12.8	5.7	13.5
		↓	13.0	13.7	13.7
Q504		RX	14.4	21.4	13.8
		TX	14.4	21.4	13.8
Q601	FM	RX	7.2	0	7.8
		TX	7.0	7.7	7.7
Q602	FM	RX	0.9	3.6	0.1
		TX	0.9	3.6	0.1
Q603		RX	0	0	0
		NB ON	0	0	0
Q801		RX	6.8	6.2	15
		TX	6.8	6.2	15
Q802		RX	15.0	21.4	14.4
		TX	15.0	21.4	14.4

CONDITIONS :

Supply voltage : 220V 60 Hz (AC)

Digital Voltmeter : HP 3476A

Channel : 19 CH

Mode : AM (\* FM)

Other specifications should correspond to measurement conditions.

#### IV. MEASUREMENT CONDITIONS

##### A. SPECIFICATIONS

###### 1. Conditions

Supply Voltage	:	220 V 60 Hz
ANT Output Impedance	:	50 ohms
Temperature	:	25° C
SSB MOD Freq	:	500 Hz & 2.400 Hz (Two Tone)
SSB MOD Freq	:	1 KHz (Single Tone)
AM, FM Mod Freq	:	1 KHz
SSG Output Level	:	0 dB $\mu$ V = 0.5 $\mu$ V
Standard Audio Output	:	0.5W
Audio Load	:	8 ohms
Channel	:	19 CH

Unless otherwise specified, switches, volumes, etc. shall be set as follows :

ANL/NB	:	OFF
HI CUT	:	OFF
CH 19	:	OFF
VOLUME	:	MAX
SQUELCH	:	MIN
MIC GAIN	:	MAX
CLARIFIER	:	CENTER
RF GAIN	:	MAX

Note : SSG Connection

- a) In measuring distortion rate at 80 % and 100 % MOD, make sure to make corrections on SSG MOD by oscilloscope.
- b) Check that there are no deviations in MOD waveform and MOD at 3 SSG outputs of 66 dB, 86 dB and 100 dB.

## 2. Transmitter

NO.	ITEM	UNIT	AM	SSB	FM
1	Frequency Tolerance	Hz	within $\pm 800$	within $\pm 800$	within $\pm 800$
2	Mic Sensitivity (AM 1 KHz at 50 % MOD, SSB 6 Wpеп, FM $\pm 1$ KHz Dev.)	mV	2 MAX	2 MAX	2 MAX
3	Hum and Noise Ratio (1 KHz 50 % MOD STD., FM $\pm 1.5$ KHz Dev.)	dB	40 MIN	-	30 MIN
4	Output Power (at NO MOD)	W	3.6 - 4.4	-	3.6 - 4.4
5	Output Power Diff. Between Channels Channels (at NO MOD)	W	0.4 MAX	-	0.4 MAX
6	Power at AM 80 % MOD (1KHz MOD)	%	Increased From NO MOD	-	-
7	MOD Distortion Rate (1KHz at 80 % MOD, FM $\pm 1.5$ KHz Dev)	%	9 MAX	-	9 MAX
8	AMC Range (Input ratio from 50 % MOD to 100 % MOD)	dB	40 MIN	-	-
9	SSB TX MAX Output 10 Wpеп - 10 dB (2 signals, IMD, 3rd - 25 dB or less)	Wpеп	-	10.8 - 13.2	-
10	SSB TX Power Error (6 Wpеп, Mic input Ratio)	dB	-	4 MAX	-
11	Power Error Between USB and LSB (6 Wpеп 2.5 KHz Single Tone)	dB	-	4 MAX	-
12	ALC Range (Input Ratio from 9 Wpеп to 13.2 Wpеп)	dB	-	40 MIN	-
13	Carrier Suppression	dB	-	-40 MAX	-
14	Maximum Deviation	$\pm$ KHz	-	-	3.5

15	Spurious	dB	- 60 MAX	- 60 MAX	- 60 MAX
16	Battery Drain (at NO MOD) AC	mA	700 MAX	300 MAX	700 MAX
17	Battery Drain (AM MAX MOD, SSB MAX Wpep)	mA	700 MAX	350 MAX	700 MAX
18	MOD Frequency Response Lower (450 Hz, 1.000 Hz Standard)	dB	- 8 MIN	- 8 MIN	- 15 MIN
19	MOD Frequency Response Upper (2.500 Hz, 1.000 Hz Standard)	dB	- 8 MIN	- 8 MIN	- 10 MIN
20	Low Voltage Response (RF Ratio at 175 V AC)	W	2 MIN	6 MIN	2 MIN

### 3. Receiver

NO.	ITEM	UNIT	AM	SSB	FM
1	Antenna input at 500 mW Output (MAX Sensitivity)	dB $\mu$ V	+ 9.5 MAX	0 MAX	-
2	Sensitivity at S/N 10 dB (FM at S/N 20 dB) <small>(FM at S/N 20 dB)</small>	dB $\mu$ V	12 MAX	0 MAX	12 MAX
3	AGC (Input 100 dB standard Input when AF Output Down 10 dB)	dB	70 MIN	70 MIN	-
4	AGC Hump (Output Standard at Input 86 dB output at input of 100dB)	dB	within $\pm$ 5	within $\pm$ 5	-
5	Frequency Response : UPPER (1.000 Hz : 0 dB, 6 dB down Freq.)	Hz	1.500-3.000	2.000-4.000	1.500-4.000
6	Frequency Response : LOWER (1.000 Hz : 0 dB, 6 dB down Freq.)	Hz	200 ~ 500	100 ~ 500	200 ~ 500
7	Cross Modulation (2 Signa's, D/S Method)	dB	40 MIN	-	-
8	AF MAX Output Power (66 dB Input, 1 KHz MOD)	W	2.5 MIN	2.5 MIN	2.5 MIN
9	AF Output Power at 10 % Distortion (66 dB Input, 1 KHz MOD)	W	2 MIN	2 MIN	2 MIN
10	Distortion Rate (1 KHz at 500 mW Output)	%	within 7	within 7	within 7
11	RF Gain Control Range	dB	30 MIN	30 MIN	30 MIN
12	Hum and Noise Ratio (1 mV Input at 500 mW Output)	dB	25 MIN	30 MIN	30 MIN
13	Squelch Sensitivity (Threshold)	dB $\mu$ V	12 MAX	12 MAX	12 MAX
14	Squelch Sensitivity (Tight)	dB $\mu$ V	54 ~ 78	54 ~ 78	54 ~ 78

15	S-Meter Sensitivity <Signal"9" > (AM NO MOD, SSB 1KHz AF Output, FM NO MOD)	dB $\mu$ V	38 ~ 54	38 ~ 54	38 ~ 54
16	Clarifier Range	dB	$\pm 600 \sim \pm 2.500$	$\pm 600 \sim \pm 2.500$	$\pm 600 \sim \pm 2.500$
17	Hi Cut Effect (66dB Input, 2KHz Standard)	dB	- 3 MAX	- 3 MAX	- 3 MAX
18	Local Oscillator Stop Voltage (AC)	V	175 MAX	175 MAX	175 MAX
19	Current at No Signal (AC)	mA	200 MAX	200 MAX	200 MAX
20	Current at AF max output (AC)	mA	300 MAX	300 MAX	300 MAX
21	Sensitivity Deviation Between CH	dB	3 MAX	3 MAX	3 MAX
22	Sensitivity Deviation Between USB and LSB	dB	-	4	-
23	Adjacent Channel Rejection (fo $\pm 10$ KHz)	dB	50 MIN	60 MIN	60 MIN
24	Frequency Tolerance	Hz	within $\pm 800$	within $\pm 800$	within $\pm 800$
25	ANL/NB Loss (6 dB Input)	dB	2 ~ 12	-	-
26	ANL + NB Performance (EIA Standard)	dB	within 6	within 6	within 6
27	Image Rejection Ratio (fo $\pm 910$ KHz)	dB	70 MIN	70 MIN	70 MIN
28	1st IF Rejection Ratio (10.695 MHz)	dB	70 MIN	70 MIN	70 MIN
29	2nd IF Rejection Ratio (455 KHz)	dB	70 MIN	70 MIN	70 MIN

The squelch of this unit has hysteresis. Accordingly, squelch threshold measurement is made such that from the position when squelch started, it is returned immediately before the squelch knob opens and it is okay if a sound is produced at 6dB (1 $\mu$ V) or less.

#### Other Function Checks

- a) At TX and RX, TX and RX LED's should light.
- b) At TX, TX frequency should not change even if the clarifier is rotated.



**B. HOWLING TEST STANDARD**

**(CONNECTION)**



(Inspection Connection)

1. Set the unit to AM RX Mode and maximize volume.  
(Clarifier is at Center).
2. Tune SSG completely with the unit and set to 100 dB  
NO MOD
3. Rotate the  
and make sure that no howling occurs.

**Meter Inspection Standard**

S-Meter

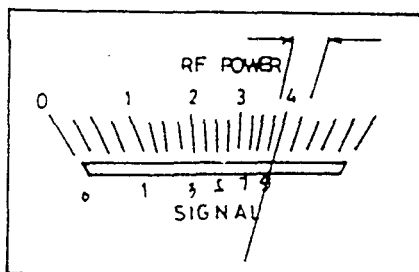

At ANT input of 40-52 dB,  
the indication should be  
within the range shown  
above.

RF-Meter

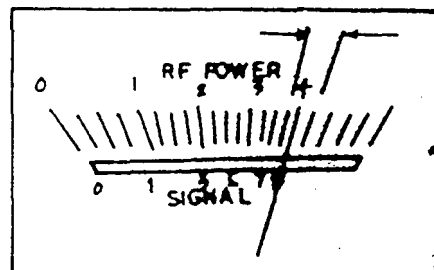

At NO MOD, the indication  
should be within the range  
shown above when output is  
4.0W.

### C. ALIGNMENT PROCEDURE

#### 1. Electro Static Discharge Test

Method : Set equipment and devise as per illustration below.  
Set voltage of equipment to 15 KV.

Discharge Cap : 150 PF

Discharge Res : 500 OHM

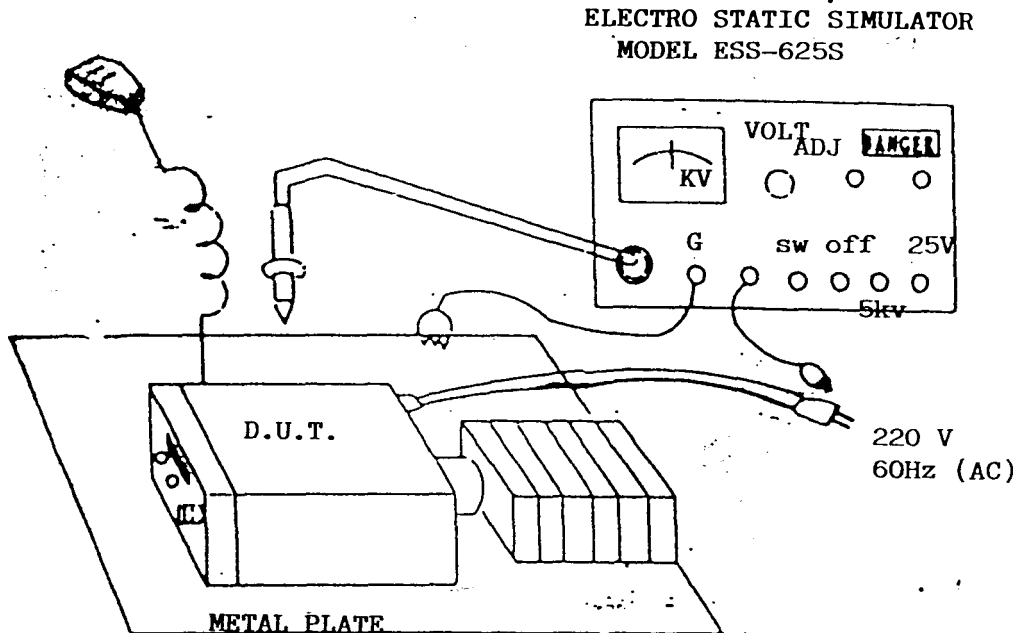

- a) Test must be done for all combinations of all controls and switch's conditions
- b) Discharge should be made 3 times with 10 seconds intervals for all control knobs, switch knobs, connectors and display window.
- c) Repeat similar test as above with opposite polarity of charge (Disconnect Dummy ANT. for test of ANT Connector)
- d) If the abnormal operation of the D.U.T. was observed, then once push power switch of D.U.T. off and on again. If D.U.T. operate satisfactory then D.U.T. be passed otherwise reject.

V. BLOCK DIAGRAM



VI. SCHEMATICS/PC BOARDS/WIRING DIAGRAM

# BLOCK DIAGRAM

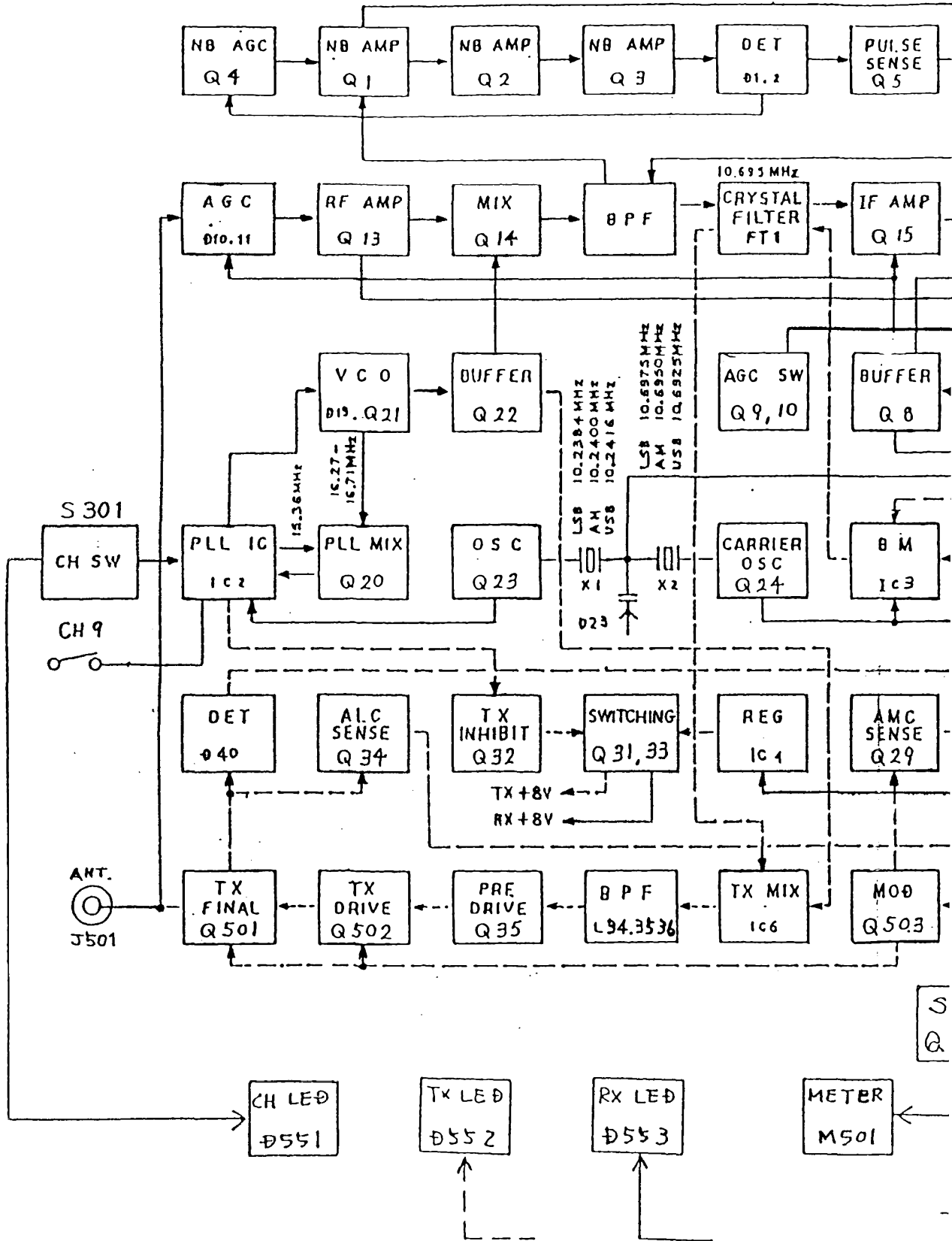



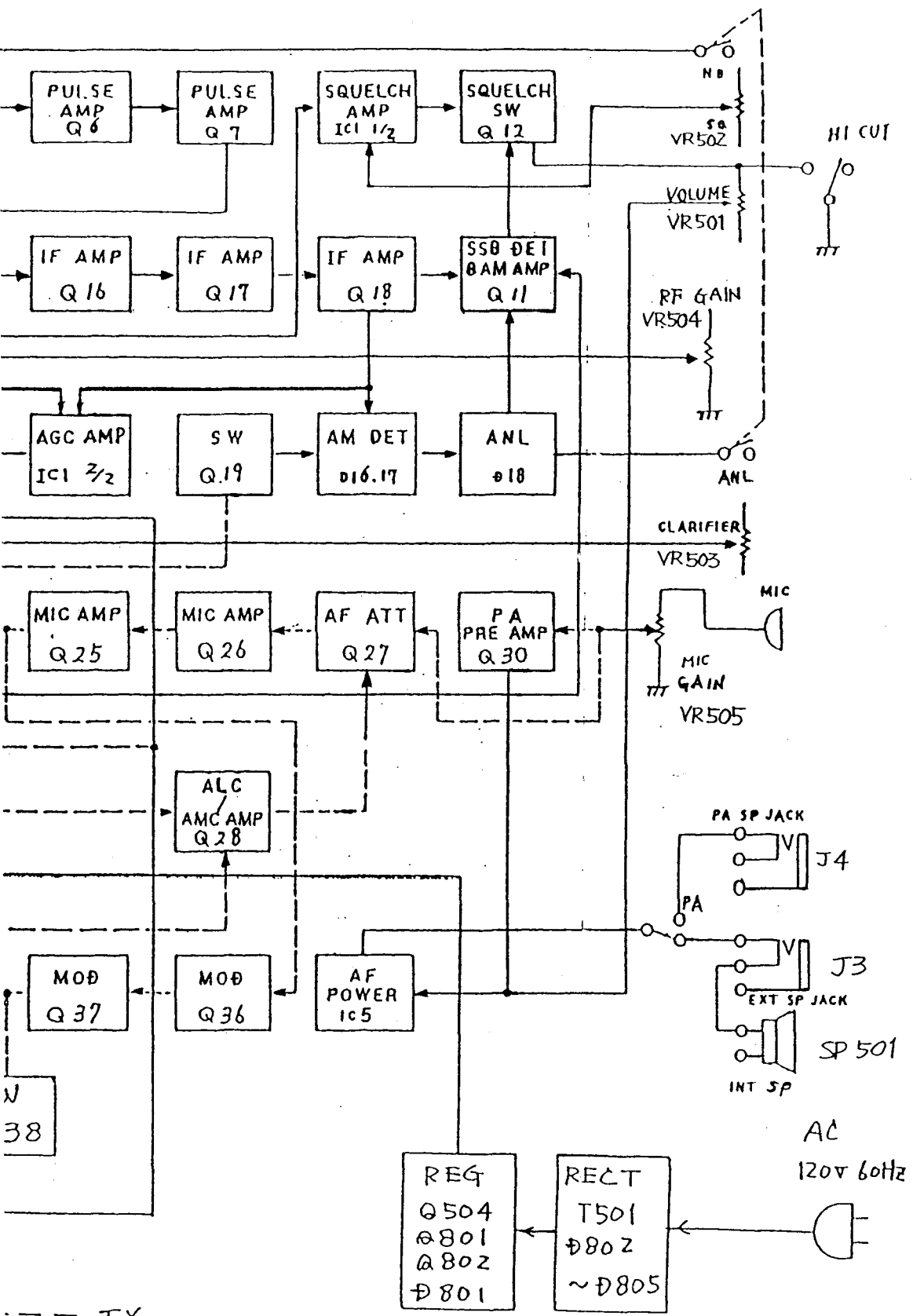

--- TX  
 — RX



Q1 25C1675L Q2 25C1675L Q3 25C1730L Q4 25C945A0 Q5 25C945A0 Q6 25A733P Q7 25C945A0

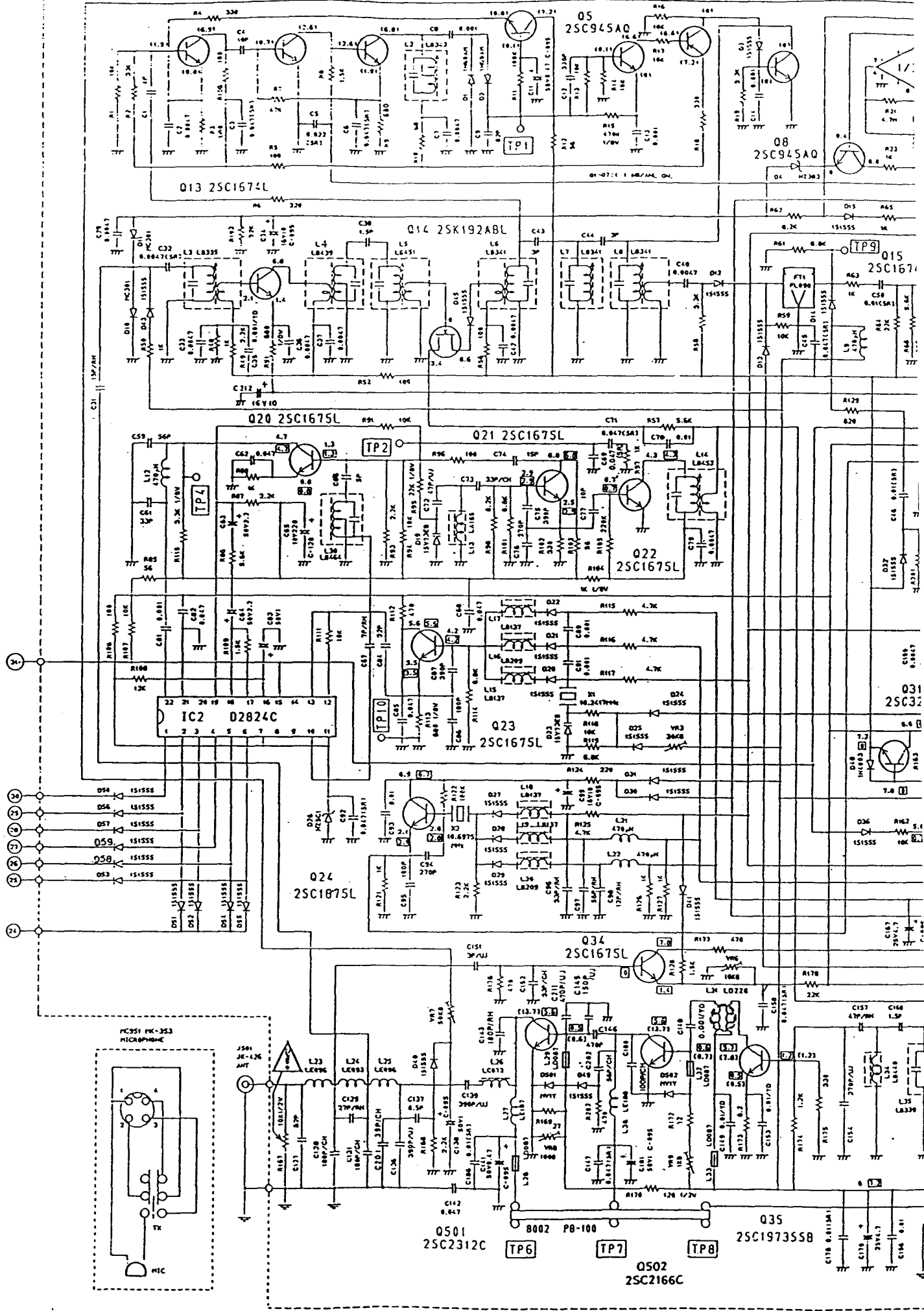

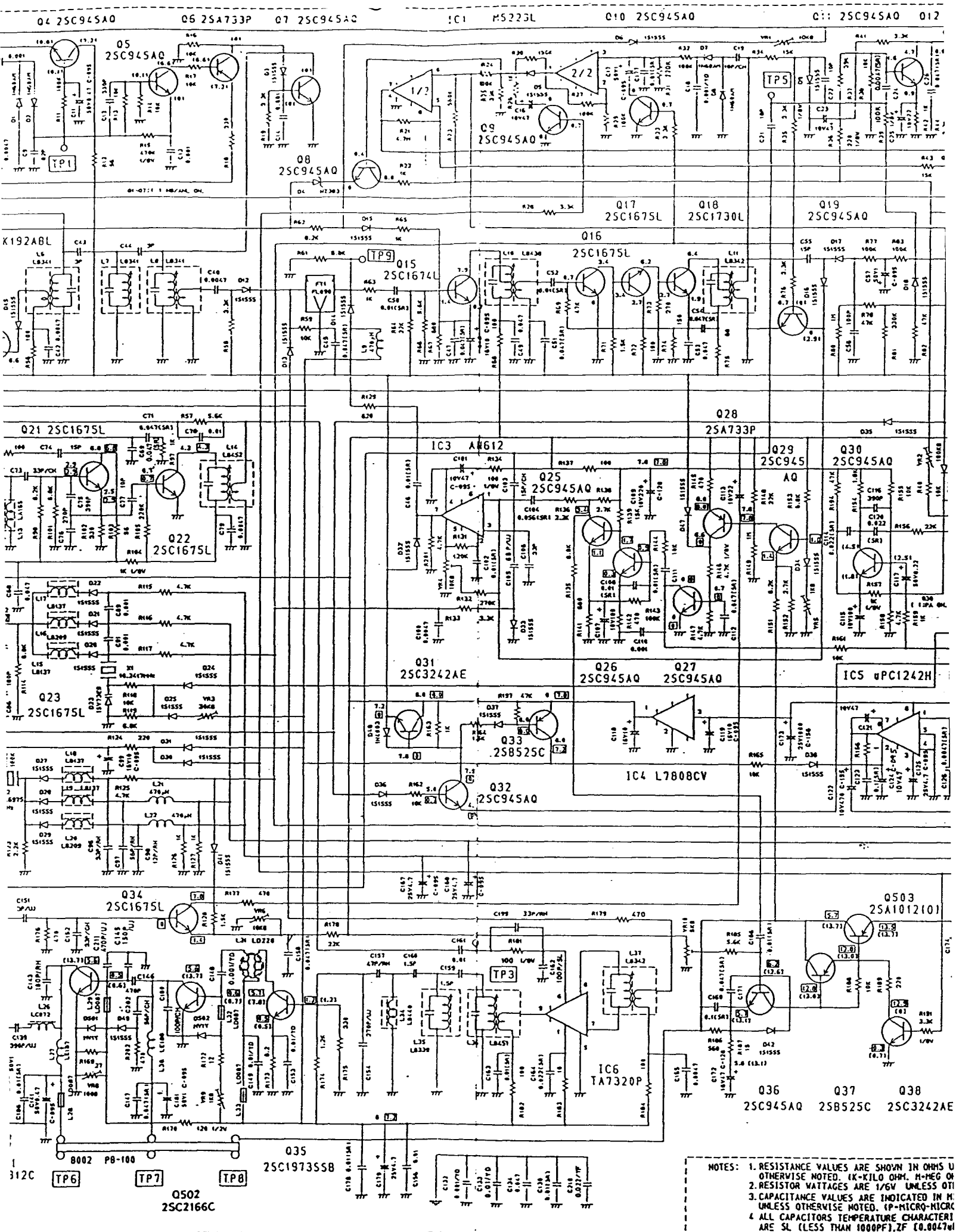

- NOTES:
1. RESISTANCE VALUES ARE SHOWN IN OHMS UNLESS OTHERWISE NOTED. 1K-KILO OHM, M-MEG OHM.
  2. RESISTOR RATINGS ARE 1/8W UNLESS OTHERWISE NOTED.
  3. CAPACITANCE VALUES ARE INDICATED IN μF UNLESS OTHERWISE NOTED. 1P-MICRO-MICRO.
  4. ALL CAPACITORS TEMPERATURE CHARACTERISTICS ARE SL (LESS THAN 1000PF), ZF (0.0047μF), YF (0.001μF-0.039μF) UNLESS OTHERWISE NOTED.
  5. DC VOLTAGE IN ( ) SHOWS TX AM CONDITN
  6. DC VOLTAGE IN [ ] SHOWS TX SSB CONDITN
  7. DC VOLTAGE IN / SHOWS RX CONDITN

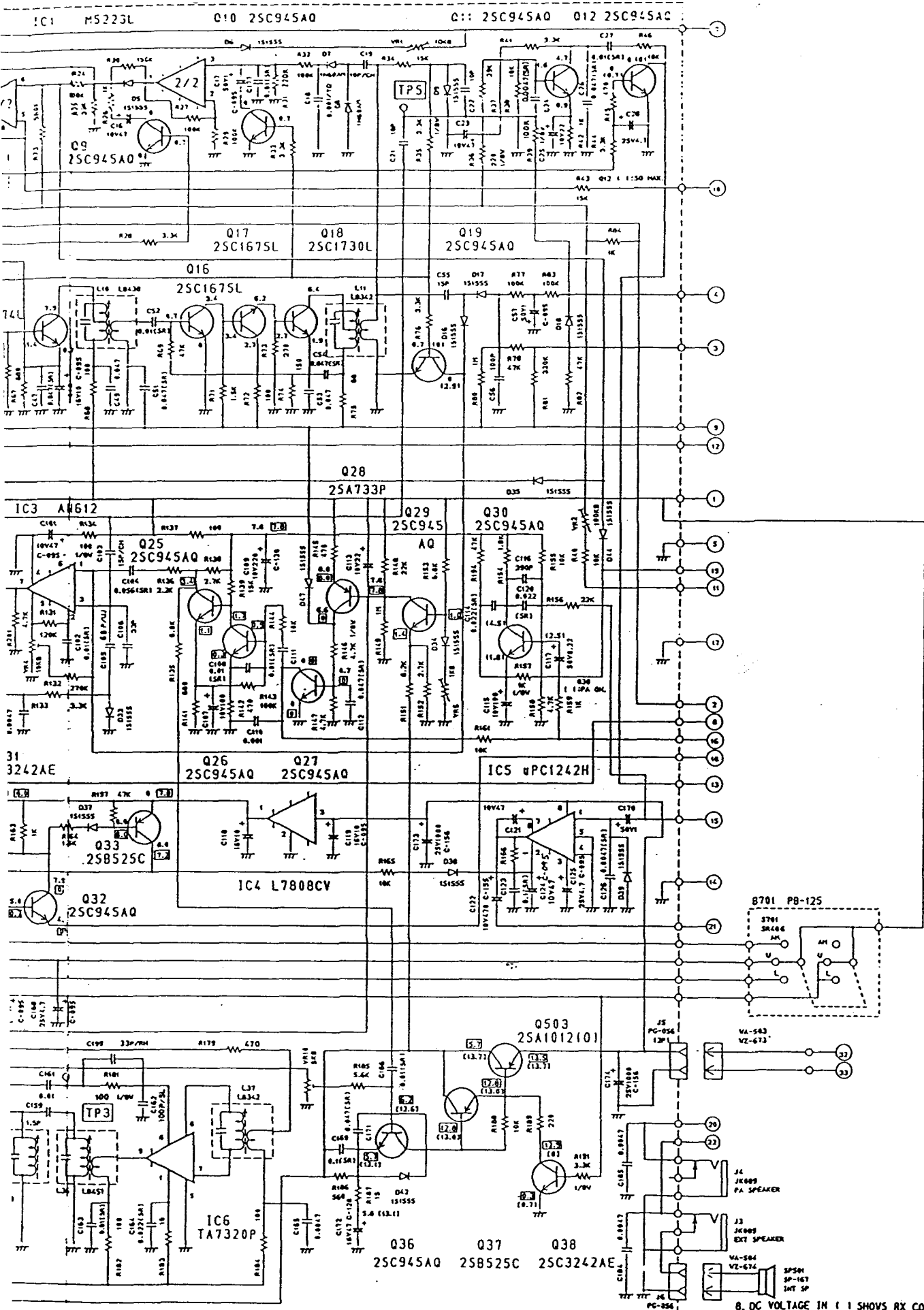

- NOTES:
1. RESISTANCE VALUES ARE SHOWN IN OHMS UNLESS OTHERWISE NOTED. 1K-KILO OHM, M-MEG OHM
  2. RESISTOR WATTAGES ARE 1/6W UNLESS OTHERWISE NOTED.
  3. CAPACITANCE VALUES ARE INDICATED IN MICRO FARADS UNLESS OTHERWISE NOTED. (P-MICRO-MICRO FARAD)
  4. ALL CAPACITORS TEMPERATURE CHARACTERISTICS ARE SL (LESS THAN 1000PF), 2F (0.0047UF) OR YF (0.001UF-0.039UF) UNLESS OTHERWISE NOTED.
  5. DC VOLTAGE IN □ SHOWS TX AM CONDITION.
  6. DC VOLTAGE IN ( ) SHOWS TX SSB CONDITION.
  7. DC VOLTAGE IN NO MARK SHOWS RX CONDITION.

8. DC VOLTAGE IN ( ) SHOWS RX CONDITION UNDER OPERATION OF EACH FUNCTION.

**PRESIDENT BENJAMIN**

TITLE	11/31
SCHEMATIC DIAGRAM	
DRAWING NO.	REV. MARK
E12-2724 1/2	

FM SCHEMATIC DIAGRAM (B60I PB-189AA)

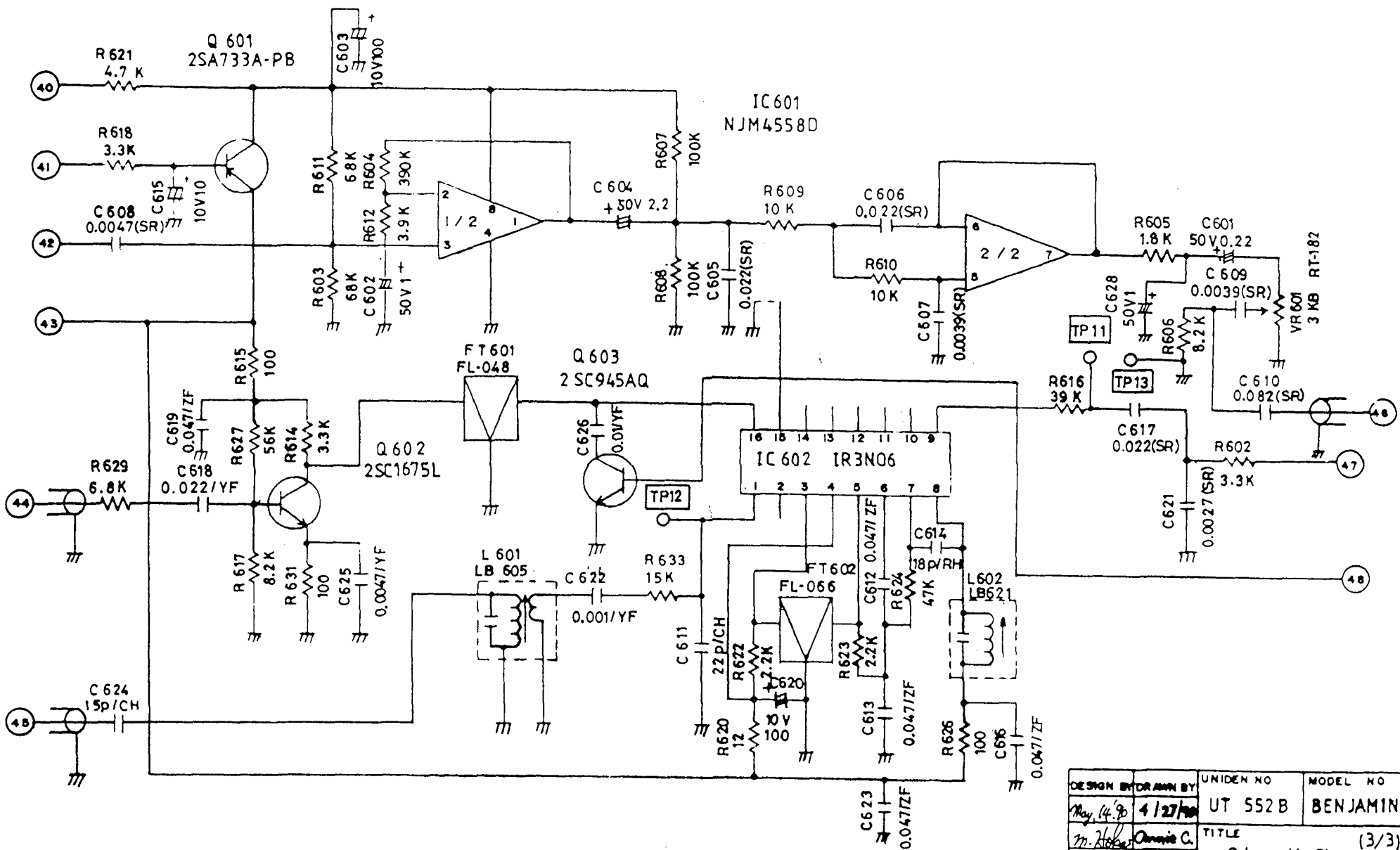

DESIGN BY <i>May 14/80</i>	DRAWN BY <i>4/27/80</i>	UNIDEN NO UT 552 B	MODEL NO BENJAMIN
CHECK BY <i>M. Hoke</i>	APPRO BY <i>Orville C.</i>	TITLE Schematic Diagram (3/3)	
	<i>May 15/80</i>	DRAWING NO ES4-0043	

# SYNTHETISEUR

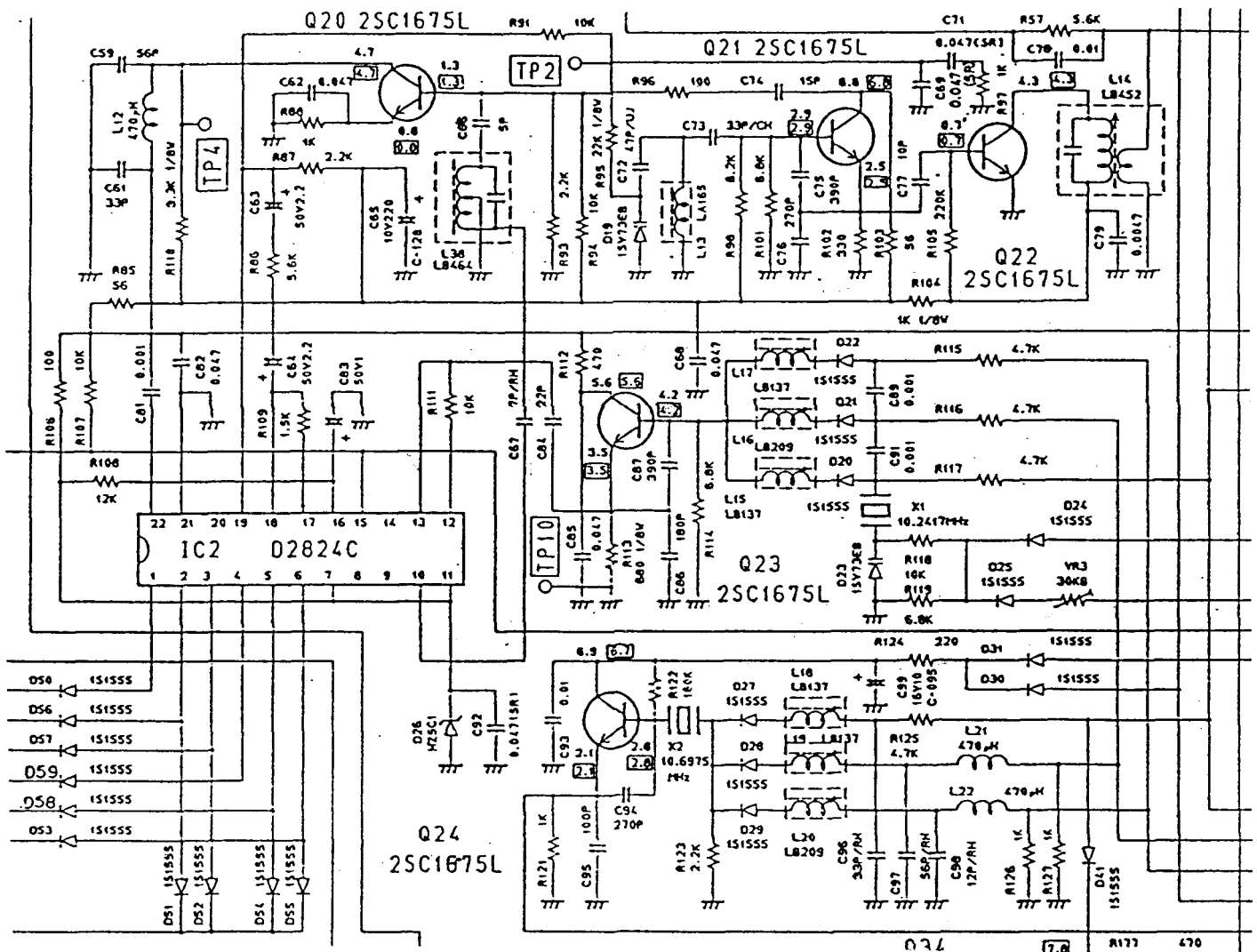



Q4 25C945A0      Q6 25A733P      Q7 25C945A0      IC1 M5223L      Q10 25C945A0

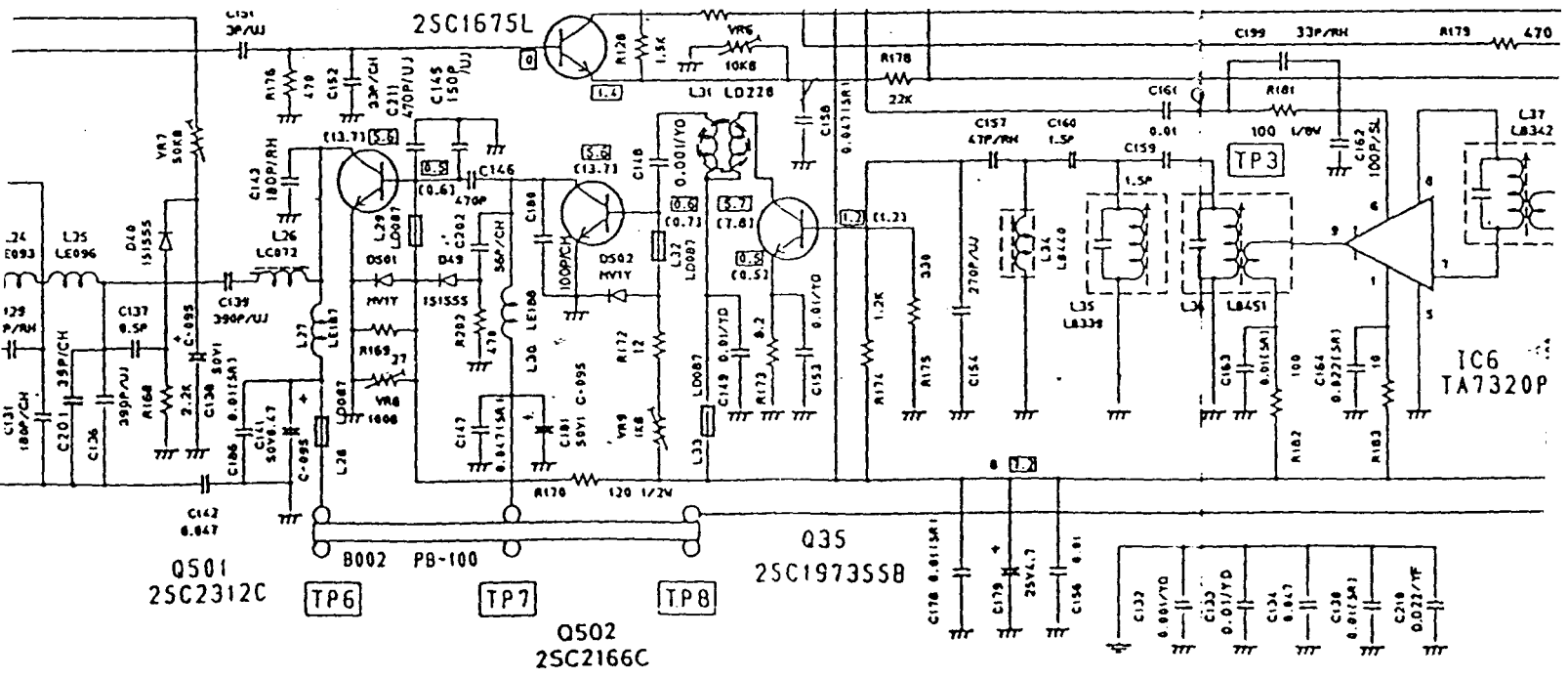
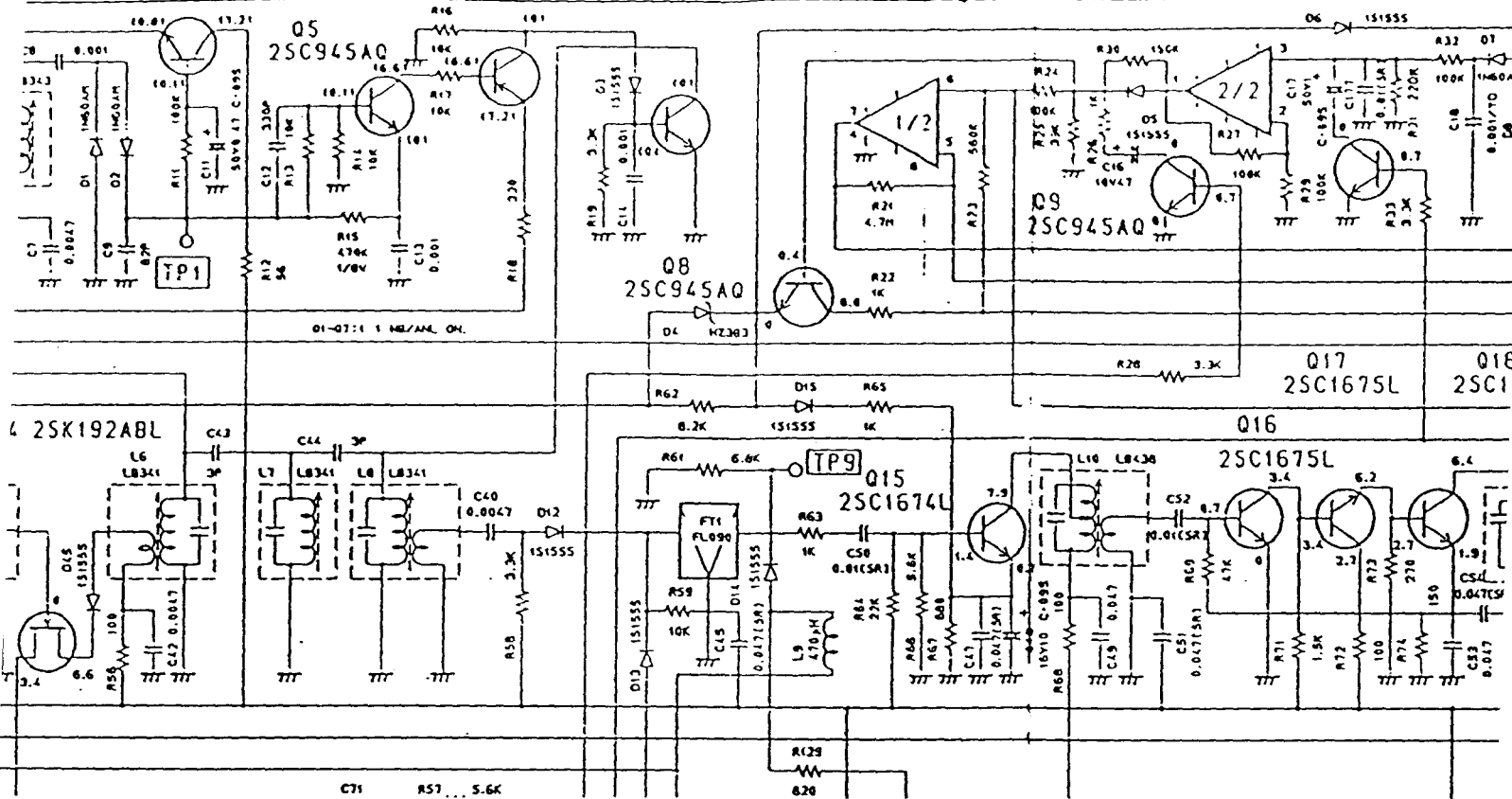

# RECEPTEUR

C945A0 IC1 M5223L Q10 25C945A0 Q11 25C945A0 Q12 25C945A0

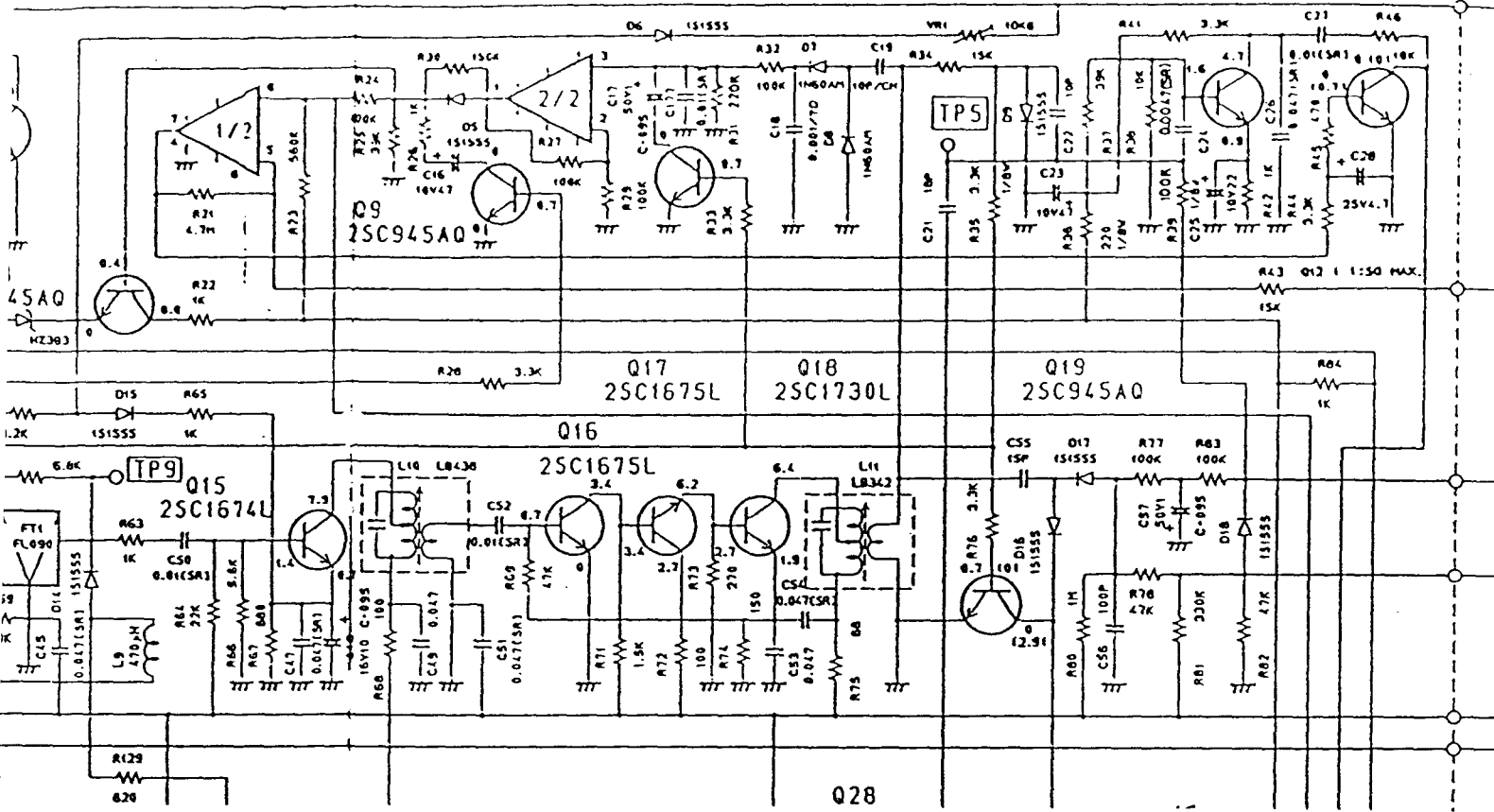

# EMETTEUR

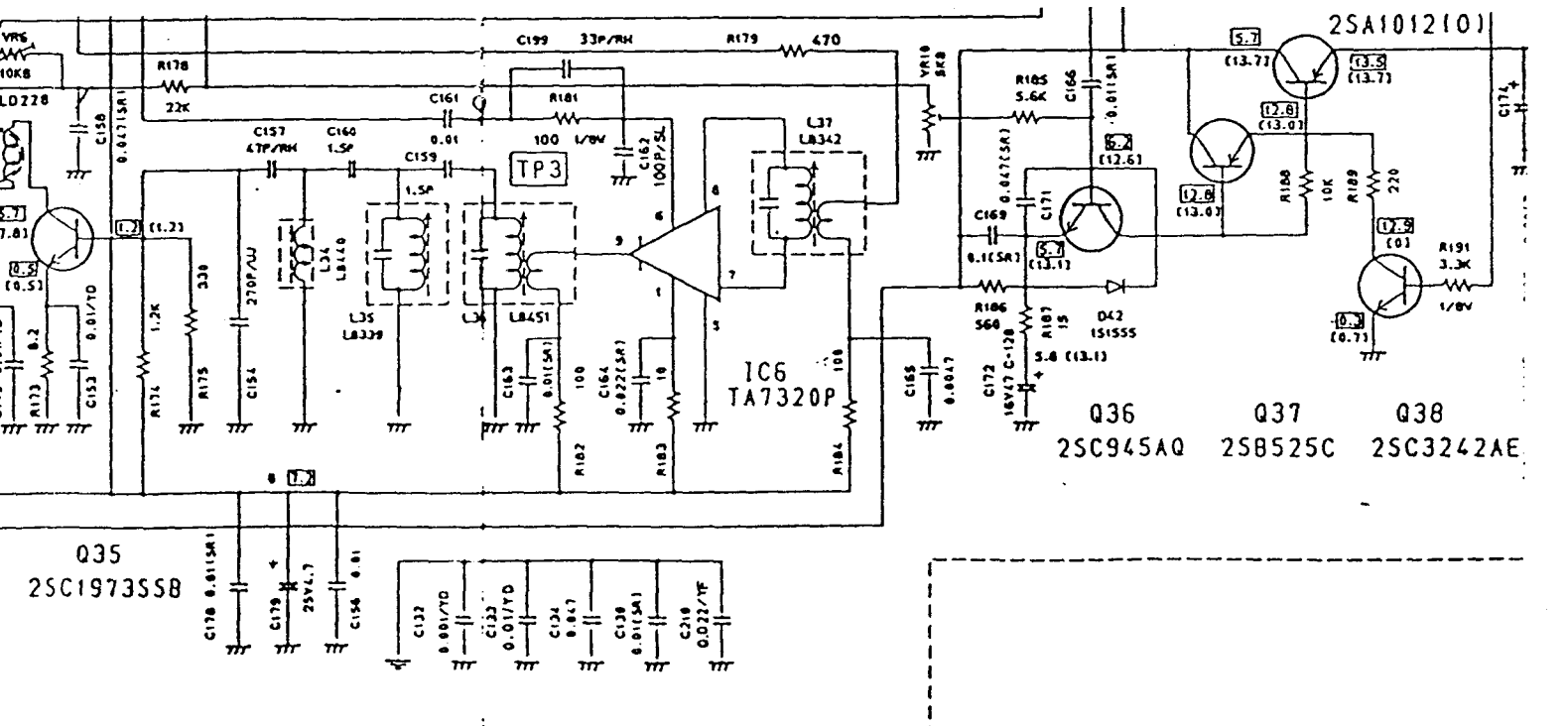



# recepteur

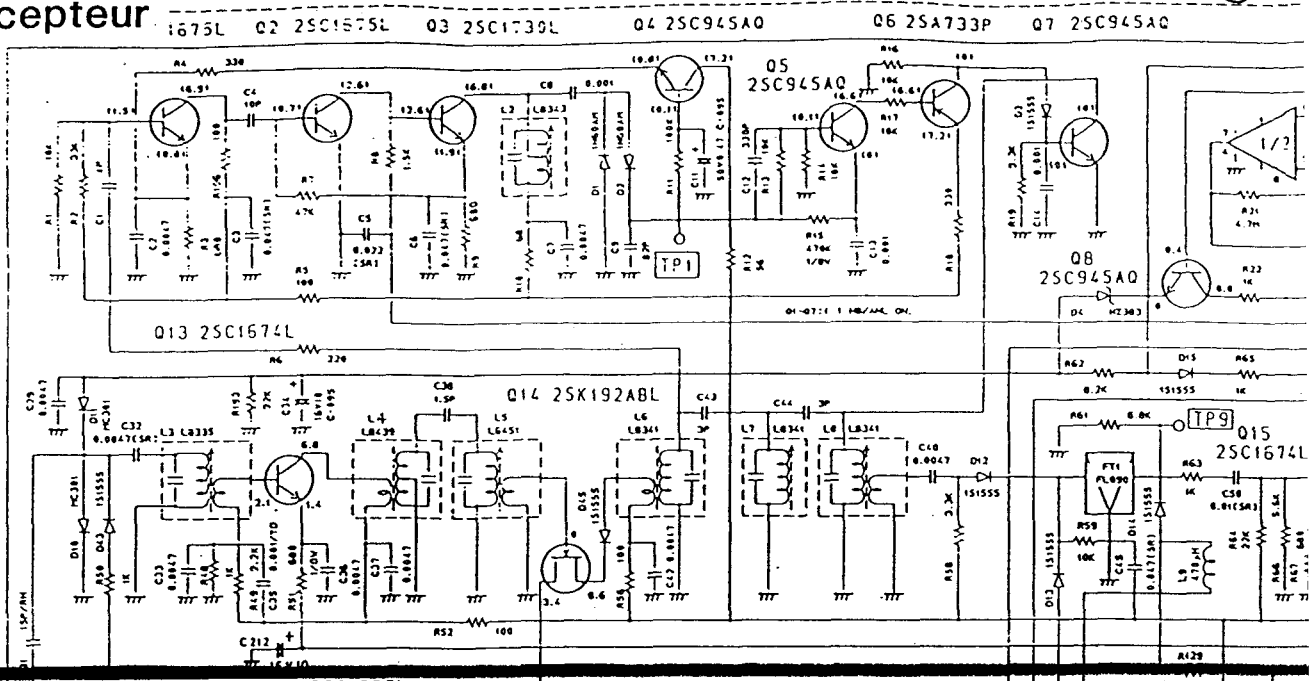

# synthétiseur

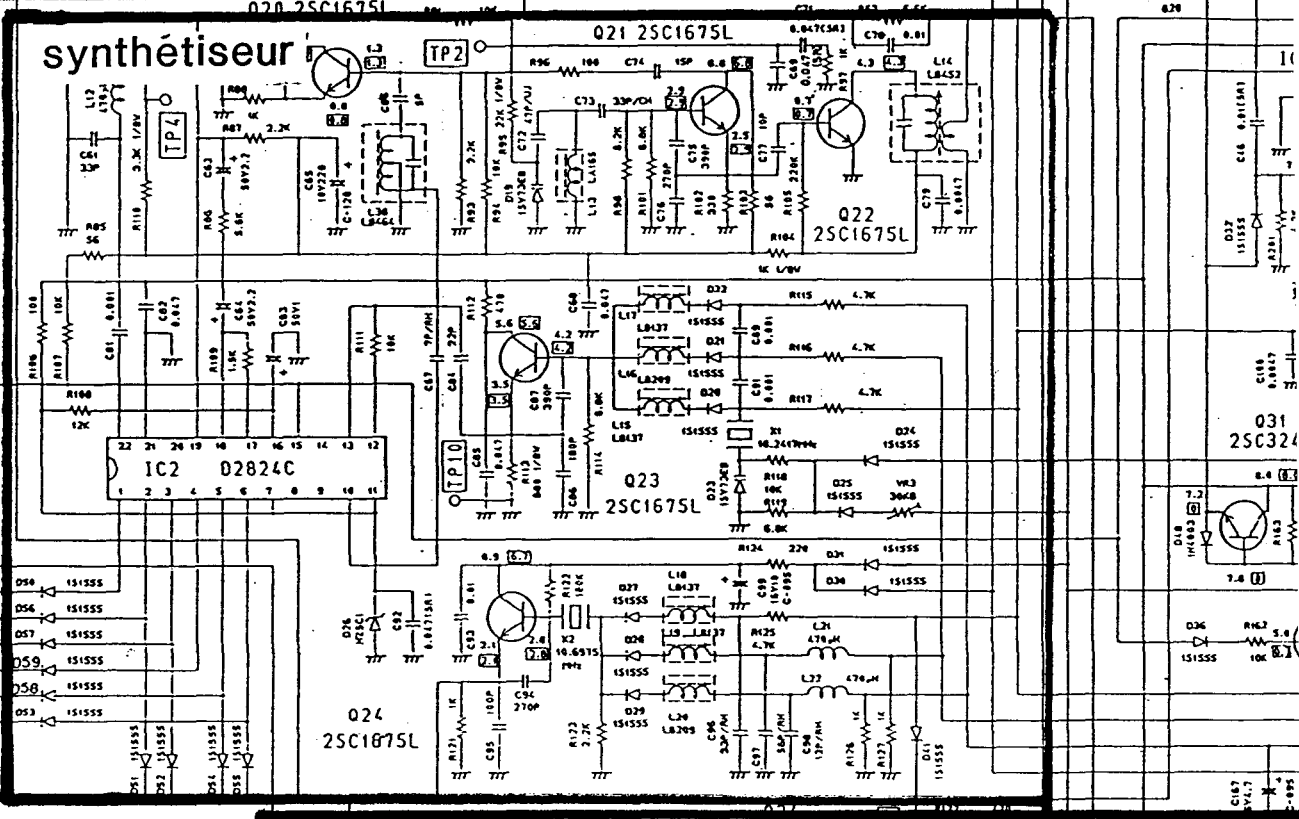

# émetteur

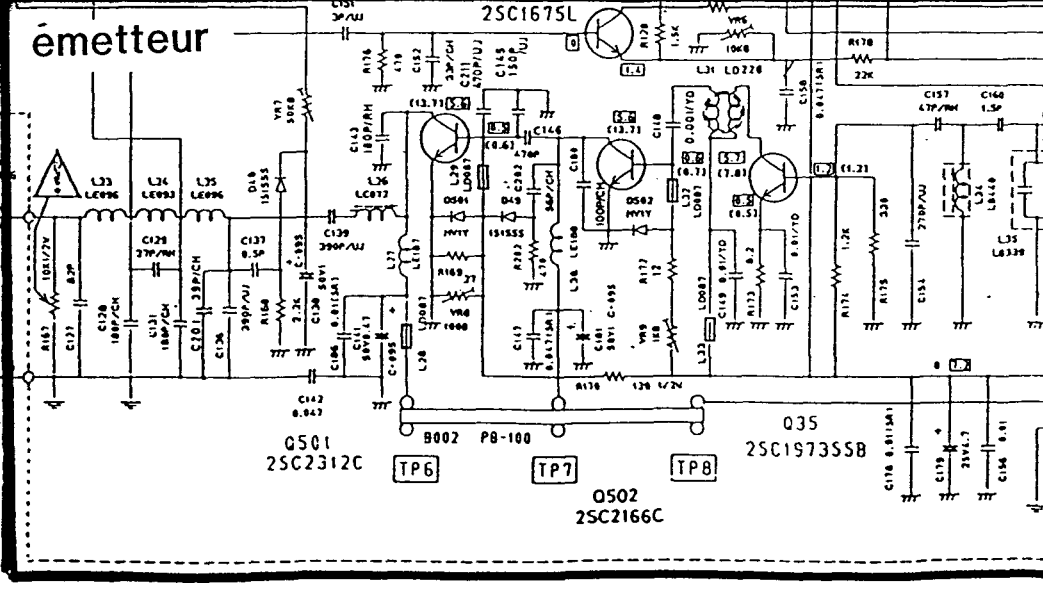

- 24
- 25
- 26
- 27
- 28
- 29
- 30
- 31
- 32
- 33
- 34
- 35
- 36
- 37
- 38
- 39
- 40
- 41
- 42
- 43
- 44
- 45
- 46
- 47
- 48
- 49
- 50
- 51
- 52
- 53
- 54
- 55
- 56
- 57
- 58
- 59
- 60
- 61
- 62
- 63
- 64
- 65
- 66
- 67
- 68
- 69
- 70
- 71
- 72
- 73
- 74
- 75
- 76
- 77
- 78
- 79
- 80
- 81
- 82
- 83
- 84
- 85
- 86
- 87
- 88
- 89
- 90
- 91
- 92
- 93
- 94
- 95
- 96
- 97
- 98
- 99
- 100

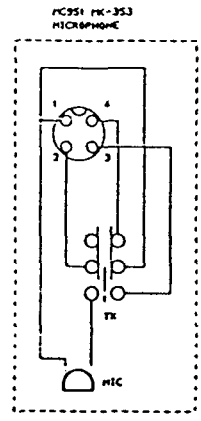



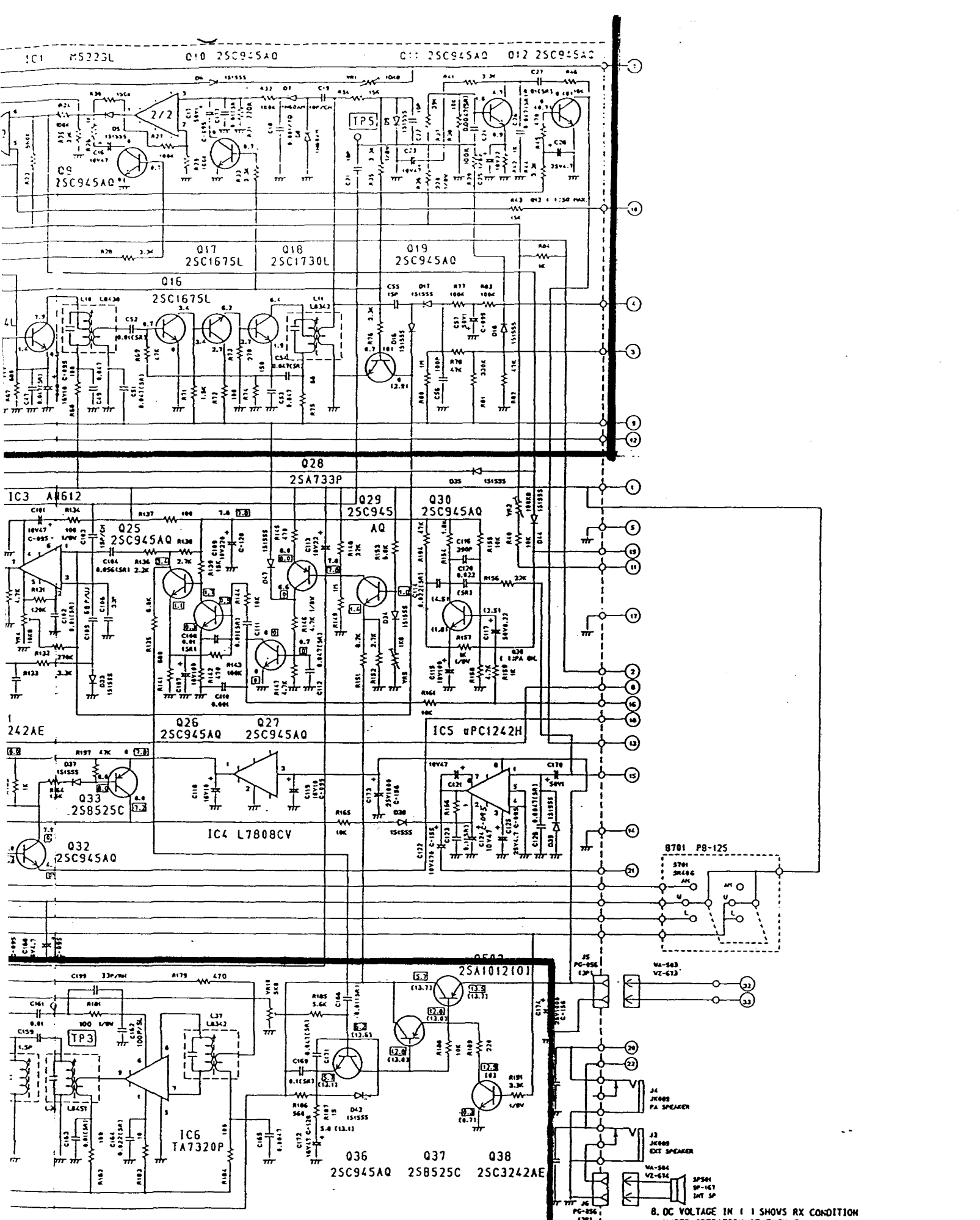

C132	0.01/10
C133	0.01/10
C134	0.01/10
C135	0.01/10
C136	0.01/10
C137	0.01/10
C138	0.01/10
C139	0.01/10

- NOTES: 1. RESISTOR VALUES ARE SHOWN IN OHMS UNLESS OTHERWISE NOTED. 1K-KILO OHM, M-MEG OHM.  
 2. RESISTOR WATTAGES ARE 1/6W UNLESS OTHERWISE NOTED.  
 3. CAPACITANCE VALUES ARE INDICATED IN MICRO FARADS UNLESS OTHERWISE NOTED. 1P-MICRO-MICRO FARAD.  
 4. ALL CAPACITORS TEMPERATURE CHARACTERISTICS ARE SL (LESS THAN 100PF), 2F (0.0047uF) OR YF (0.001uF-0.039uF) UNLESS OTHERWISE NOTED.  
 5. DC VOLTAGE IN □ SHOWS TX AM CONDITION.  
 6. DC VOLTAGE IN [ ] SHOWS TX SSB CONDITION.  
 7. DC VOLTAGE IN ∅ MARK SHOWS RX CONDITION.

B. DC VOLTAGE IN [ ] SHOWS RX CONDITION UNDER OPERATION OF EACH FUNCTION.

**PRESIDENT BENJAMIN**

TITLE	11/31
SCHEMATIC DIAGRAM	
DRAWING NO.	REV. MARK
E12-2724	

5A

5B

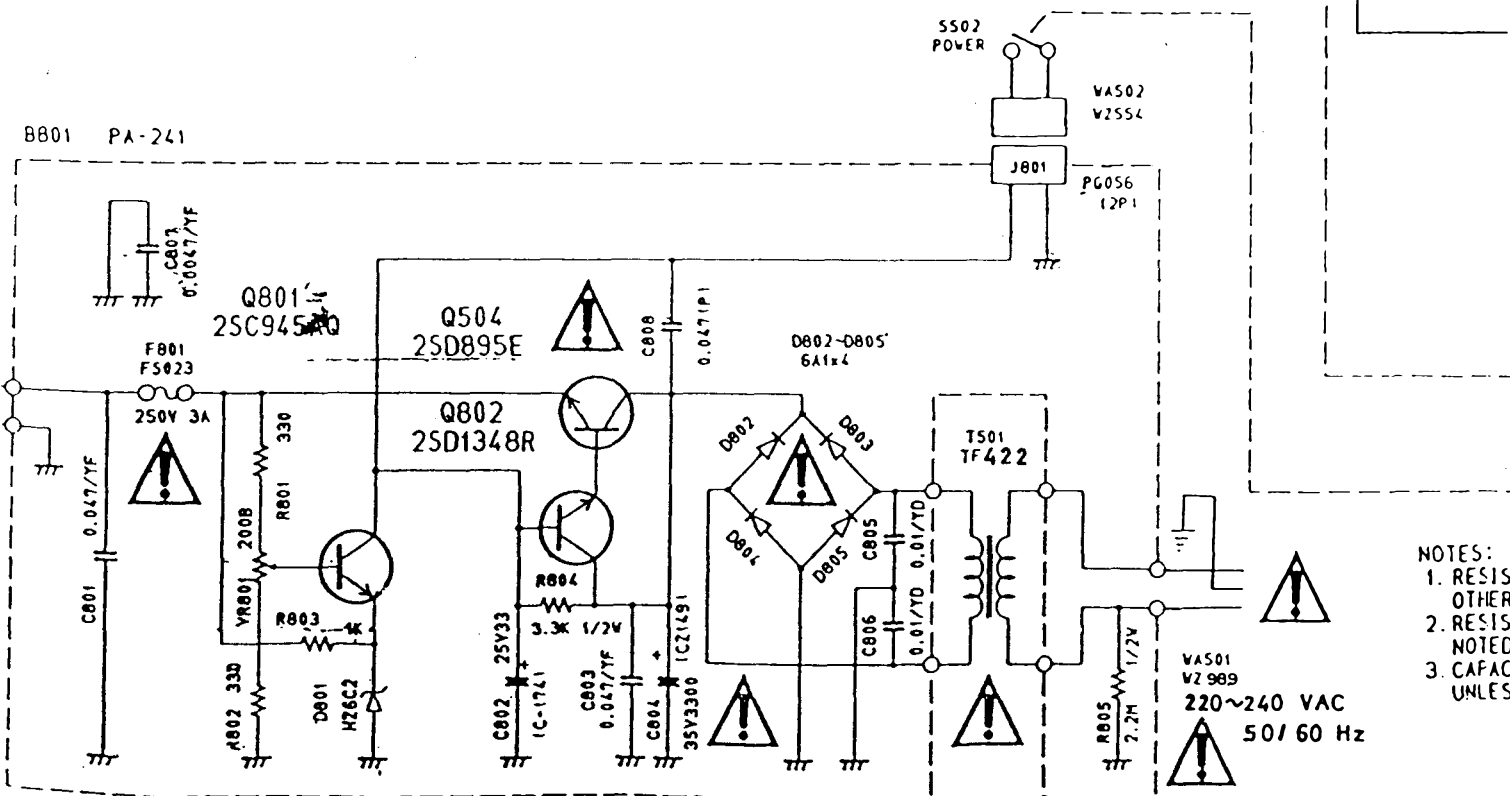
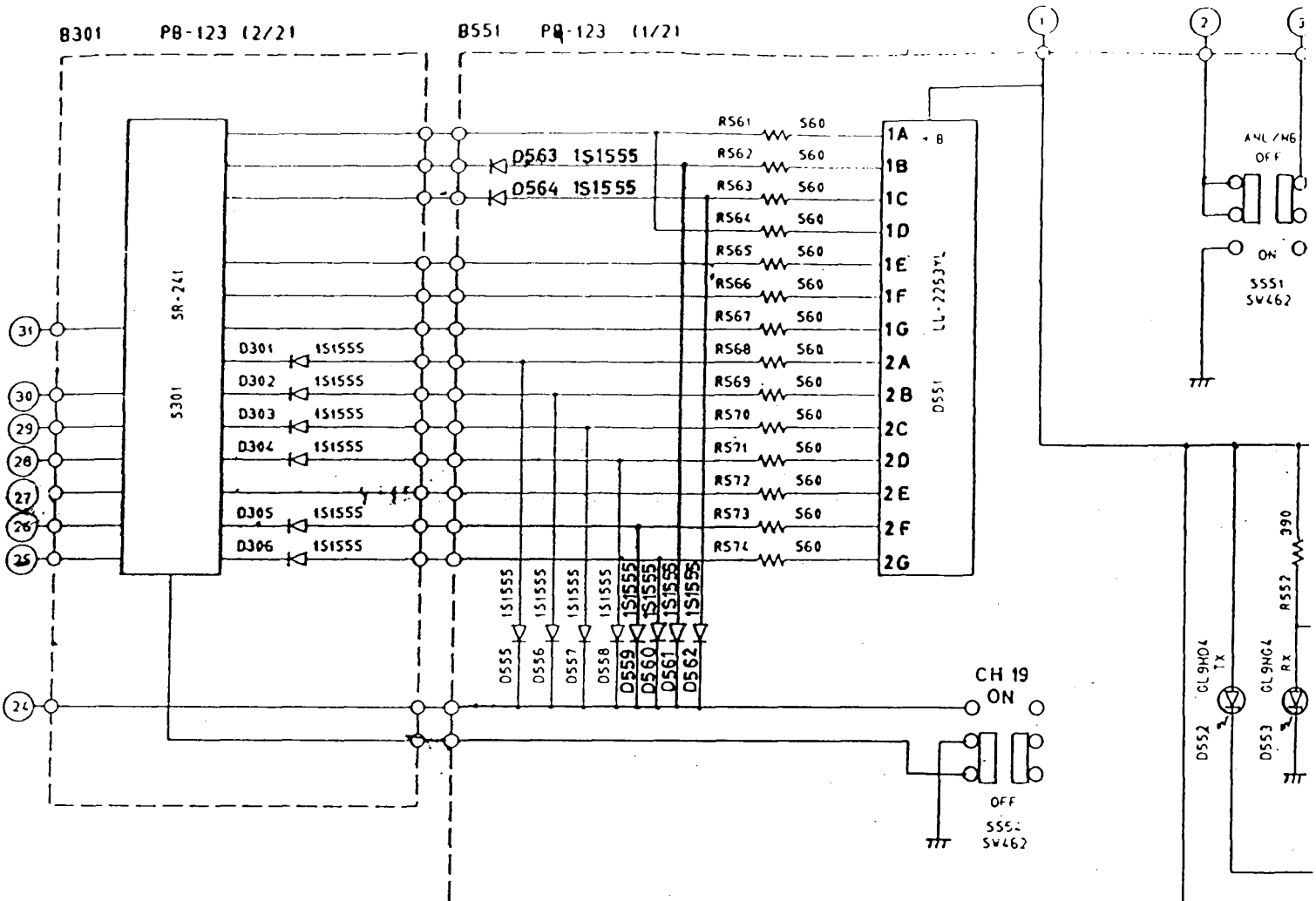

- NOTES:
1. RESIS OTHER
  2. RESIS NOTED
  3. CAPAC UNLES

5B

5C

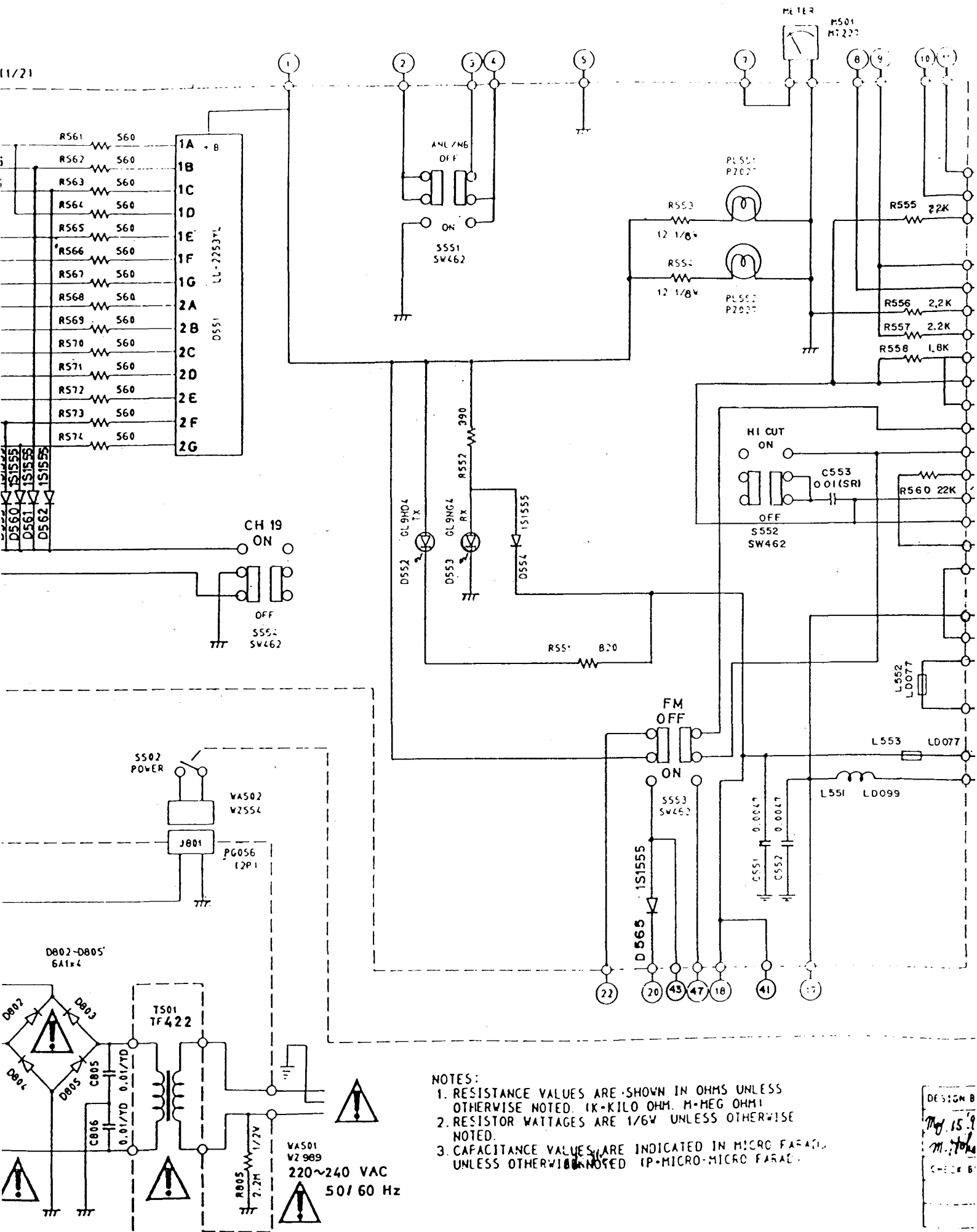

5C

5D

U7552/2::50:2

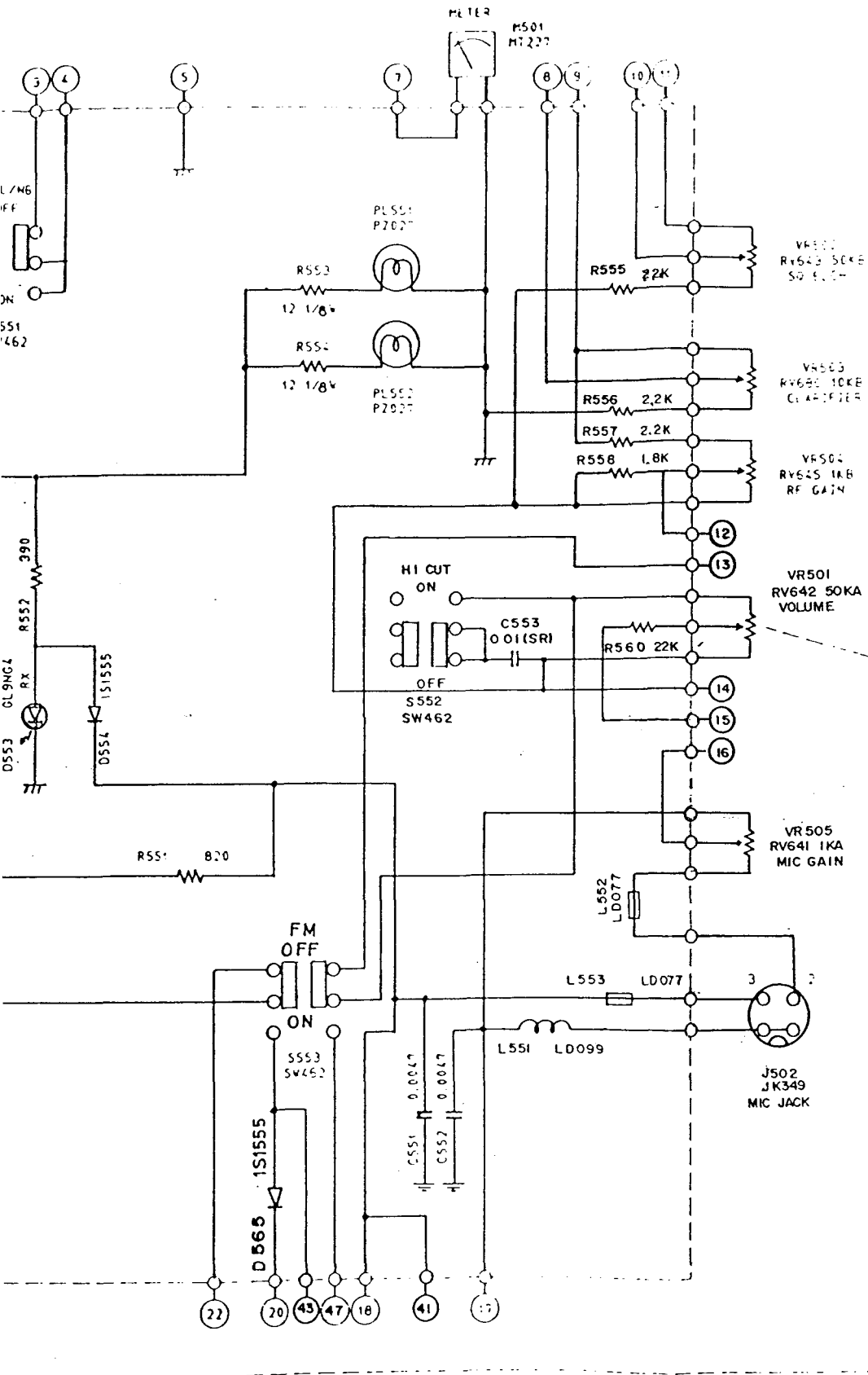

NOTES:  
 RESISTANCE VALUES ARE SHOWN IN OHMS UNLESS OTHERWISE NOTED. 1K-KILO OHM. M-MEG OHM.  
 RESISTOR WATTAGES ARE 1/8W UNLESS OTHERWISE NOTED.  
 CAPACITANCE VALUES ARE INDICATED IN MICRO FARADS UNLESS OTHERWISE NOTED. 1P-MICRO-MICRO FARAD.

DESIGN BY <i>M. Mohai</i>	DRAWN BY <i>Nov. 16, 1990</i>	UNIDEN NO U7552 B	MODEL NO BENJAMIN
CHECK BY <i>Kater</i>	APPROV BY <i>5/15/90</i>	SCHEMATIC DIAGRAM	
DRAWING NO ES3-0025		REV MARK	

UNIDEN CORP

**MODULE BENJAMIN 120  
VERSION EXPORT**

X1: 14.816  
X2: 15.816  
X3: 15.370

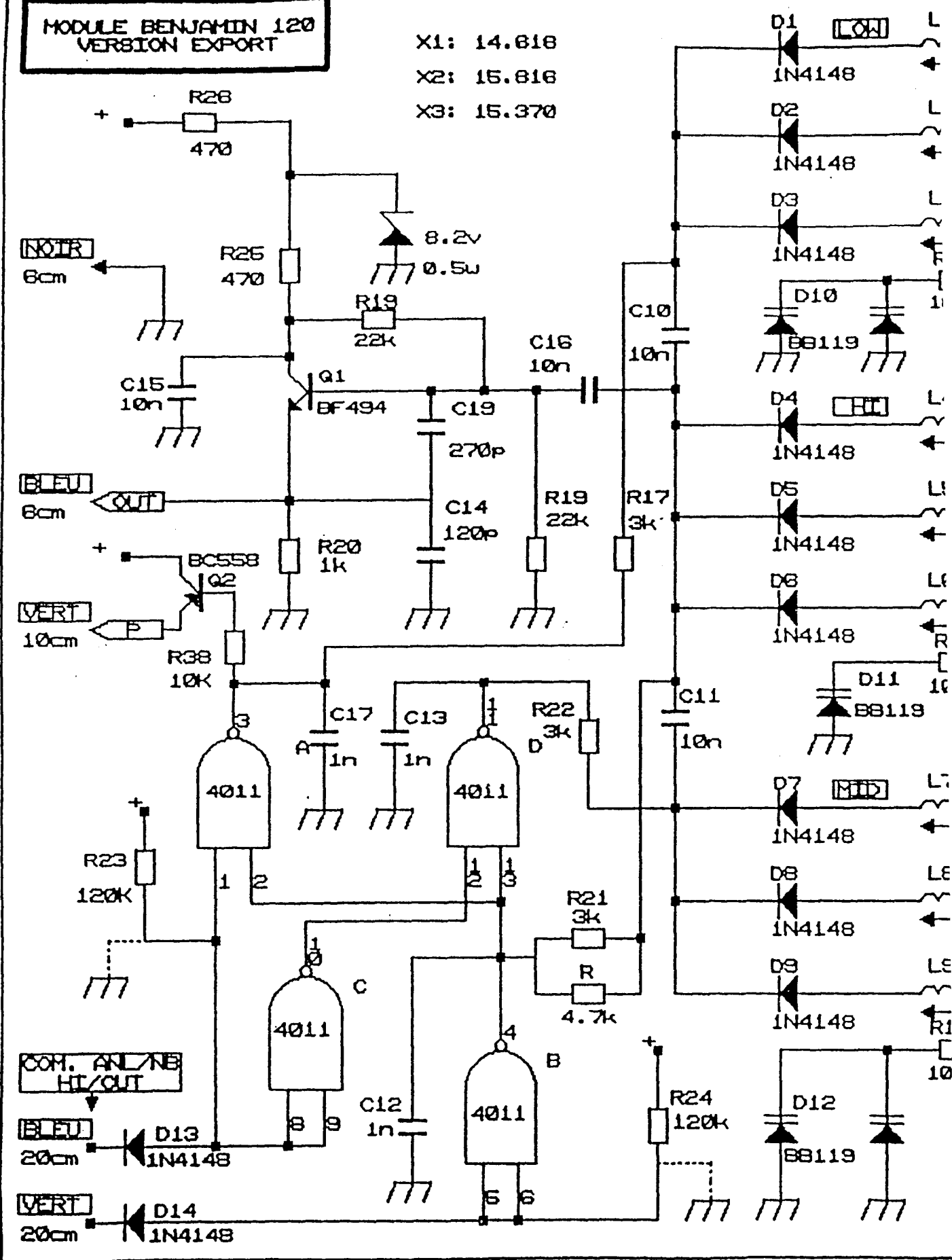

6A

6B

: 14.618  
 : 15.616  
 : 15.370

.2v  
 .5w

C19  
 270p

C14  
 120p

7

3

4011

4011

B

+

6B

6C

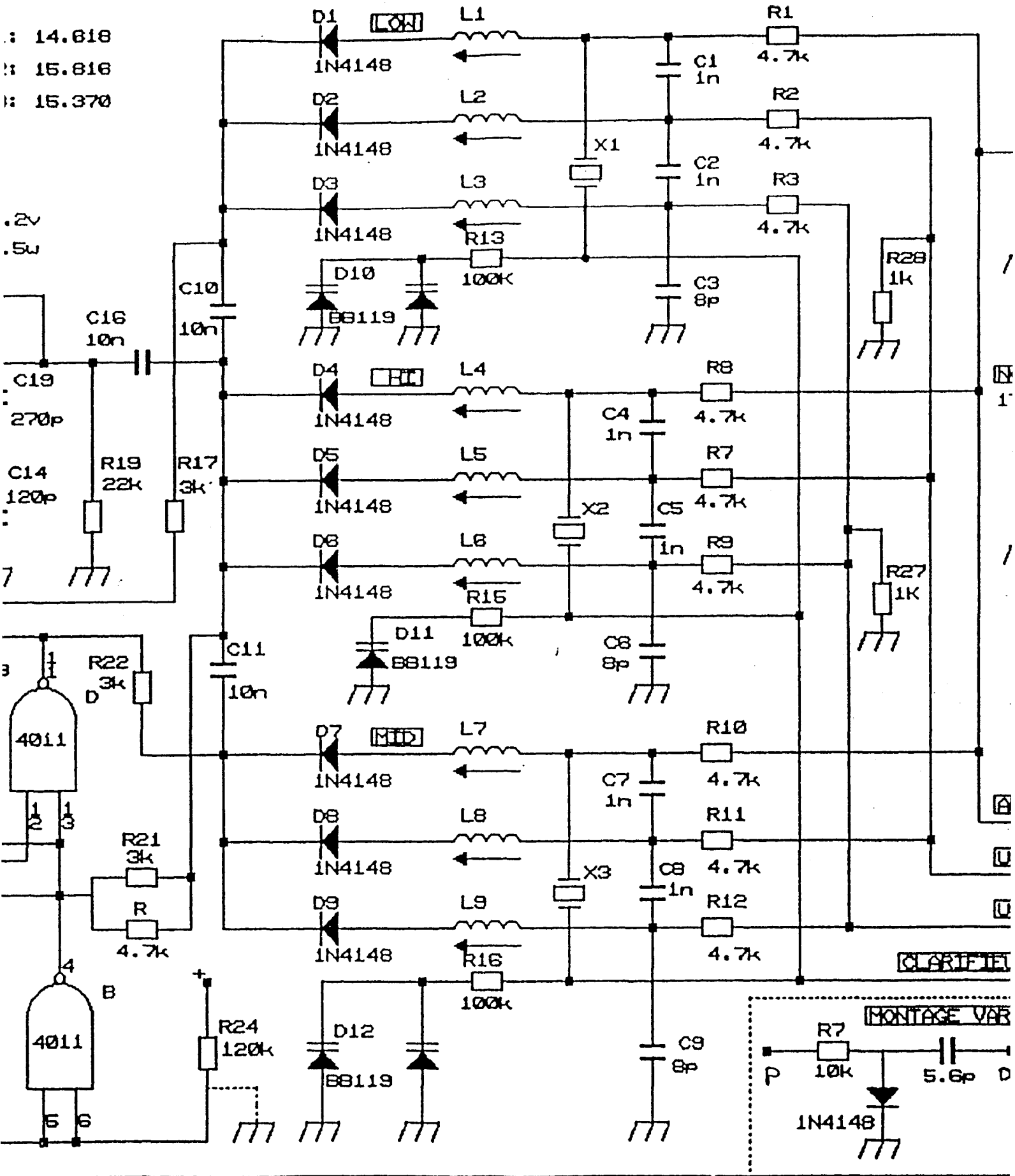

CLARIFIÉ

MONTAGE VAR

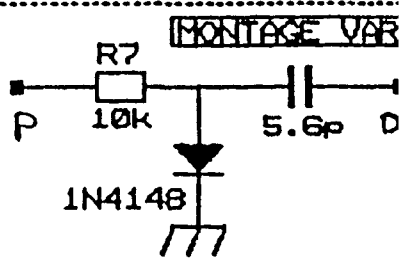



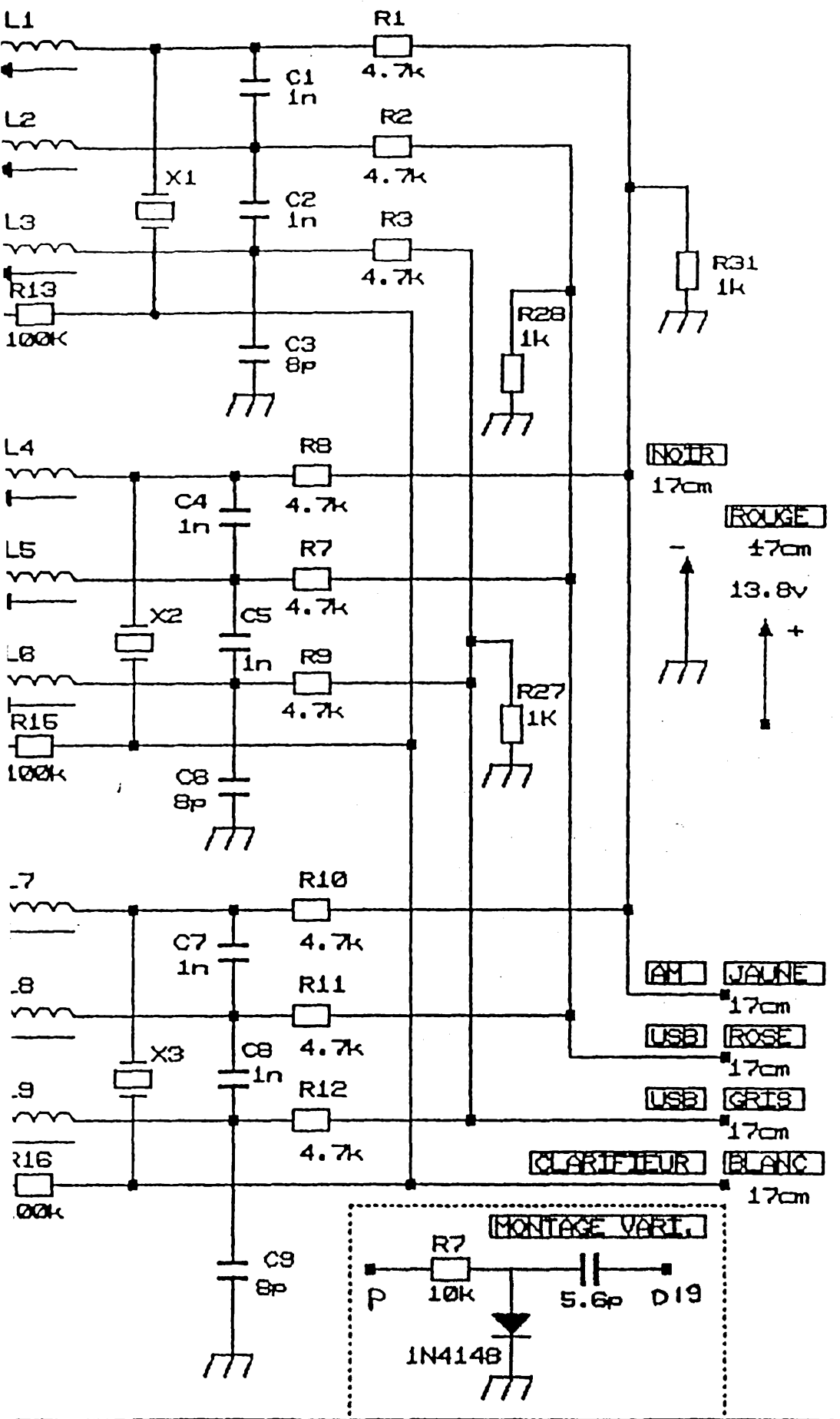

6C

6D

# MESURES

SYMB NO.	PIN NO.	RX/TX	VOLTAGE
IC 1	1	RX	0.2
	2		0.1
	3		0.1
	4		0
	5		1.2
	6		1.5
	7		0
	8		8.0
IC 2	1	RX TX	5.1
	2		0
	3		0
	4		5.1
	5		5.1
	6		0
	7		5.1
	8		-
	9		-
	10		2.0
	11		5.1
	12		2.5
	13		2.5
	14		-
15		5.2	
16		5.1	
17		1.6	
18		1.6	
19		3.9	
20		-	
21		0	
22		2.4	
IC 3	1	RX TX	0
	2		3.3
	3		3.2
	4		0
	5		5.8
	6		7.3
	7		6.6
IC 4	1	RX TX	3.6 8.0
	2		0

SYMB NO.	PIN NO.	RX/TX	VOLTAGE
IC 5	3		13.7
	1	RX	0.1
	2		1.9
	3		1.3
	4		0
	5		0
	6		7.0
	7		12.7
IC 6	8		13.7
	1	TX	7.6
	2		-
	3		-
	4		-
	5		0
	6		2.6
	7		4.2
	8		4.2
	9		7.4
	1	TX	4
	2		3.9
	3		3.9
	4		0
	5		3.9
	6		3.9
7		3.9	
IC601	8		7.8
	1	RX	7.7
	2		7.1
	3		7.4
	4		7.7
	5		1
	6		1
	7		1
	8		7.8
	9		3.3
	10		0
	11		7.2
	12		0
	13		7.1
	14		0
	15		0
IC602	16		0

# MESURES

SYMBOL NO.	*	RX TX	BASE GATE	COLLECTION DRAIN	EMITTER SOURCE
Q1		RX NB ON	1.5	6.9	0.8
Q2			0.7	2.6	0
Q3			2.6	6.8	1.9
Q4			0.1	7.2	0.8
Q5			0.1	6.6	0
Q6			6.6	0	7.2
Q7		∇	0	0	0
Q8		RX	0.4	8.0	0
Q9		RX	0.7	0	0
		SSB			
Q10		RX	0.7	0	0
Q11		∇	1.6	4.7	0.9
Q12	FM	RX	0	3.6	0
		TX	0.7	0	0
Q13		RX	2.1	6.8	1.4
Q14			0	6.6	3.4
Q15			1.4	7.9	0.7
Q16			0.7	3.4	0
Q17			3.4	6.2	2.7
Q18		∇	2.7	6.4	1.9
Q19		RX AM	0.7	0	0
		SSB	0	2.9	0
Q20		RX	1.3	4.7	0.8
		TX	1.3	4.7	0.8
Q21			2.9	6.8	2.5
Q22			0.7	4.3	0
			4.2	5.6	3.5
Q23		∇	4.2	5.6	3.5
Q24		RX SSB	2.8	6.9	2.1
		TX	2.8	6.7	2.1
Q25		TX	1.7	3.4	1.1
Q26		∇	0.9	1.7	0.3
Q27		RX	0.7	0	0
		TX	0	0	0
Q28		RX	7.8	6.6	8.0
		TX	7.8	0	8.0
Q29		TX	1.0	7.8	1.4
Q30		∇	2.5	4.5	1.5
Q31		RX	7.8	8.0	7.2
		TX	0	8.0	0
Q34		TX	0	7.8	1.4
		SSB	0		
Q35		TX AM	1.2	5.7	0.5
		SSB	1.2	7.8	0.5
Q36			6.2	12.2	5.7
			12.6	13.2	13.1
Q37			12.8	5.7	12.3
			13	13.7	13.2

# MESURES

SYMBOL NO.	*	RX TX	BASE GATE	COLLECTION DRAIN	EMITTER SOURCE
Q38			0.3	12.9	0
			0.7	0	0
Q501			0.5	5.6	0
			0.6	13.7	0
Q502			0.6	5.5	0
			0.7	13.7	0
Q503			12.8	5.7	13.5
		Y	13.0	13.7	13.7
Q504		RX	14.4	21.4	13.8
		TX	14.4	21.4	13.8
Q601	FM	RX	7.2	0	7.8
		TX	7.0	7.7	7.7
Q602	FM	RX	0.9	3.6	0.1
		TX	0.9	3.6	0.1
Q603		RX	0	0	0
		NB ON	0	0	0
Q801		RX	6.8	6.2	15
		TX	6.8	6.2	15
Q802		RX	15.0	21.4	14.4
		TX	15.0	21.4	14.4

# IDENTIFICATION DES SEMI-CONDUCTEURS



1N60 AM  
1N4003  
1H23B3  
1H26C2  
1H25C-1  
1S1555  
MC-301  
1SV73-EB

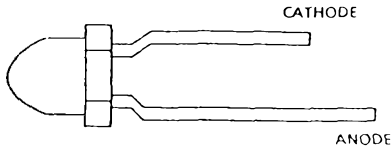

GL-9HD4

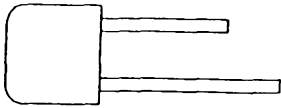

GL-9NG4

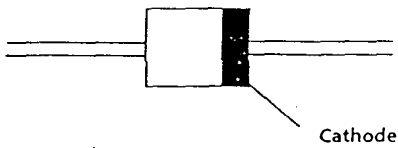

6A1

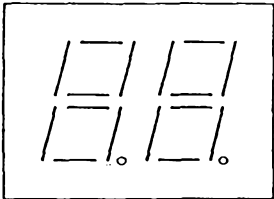

2SC2166-C

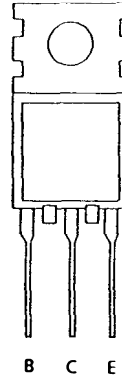

2SD895-E

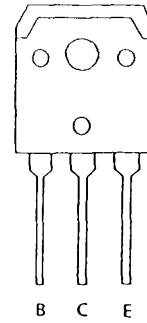

2SA1012-O

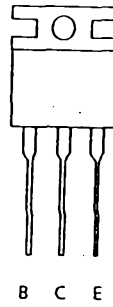

2SC2312-C

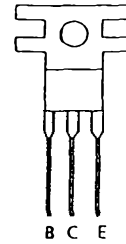

2SD1348-R

LL-2253YL

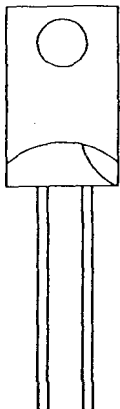

MV-1Y

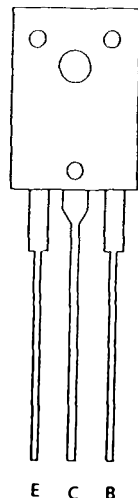

E C B

2SC1973-SSB

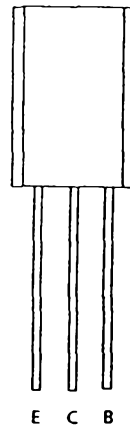

E C B

2SK192A-BL

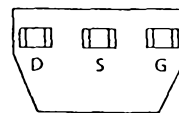

2SC3242A-E

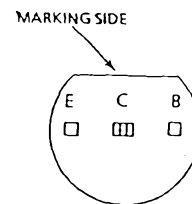

2SC1675-L  
2SC1730-L  
2SC945A-Q  
2SC1674-L  
2SA733A-PB

2SB525-C

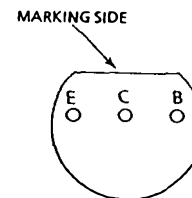
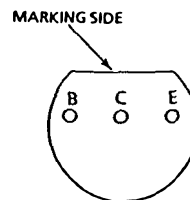

# CIRCUITS INTEGRÉS

AN612

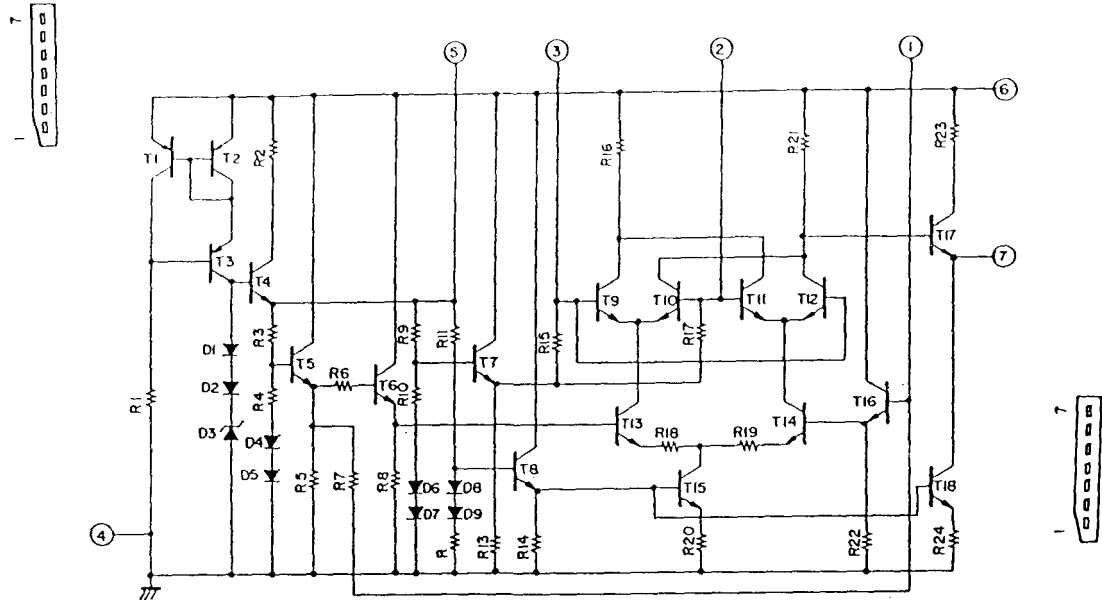

L7808CV

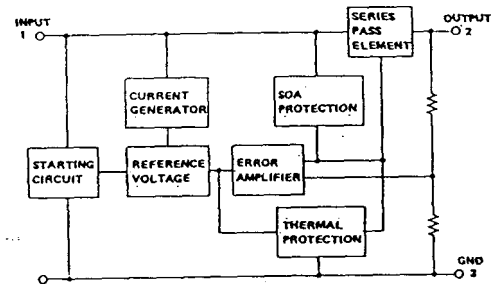
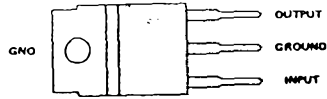

D2824C

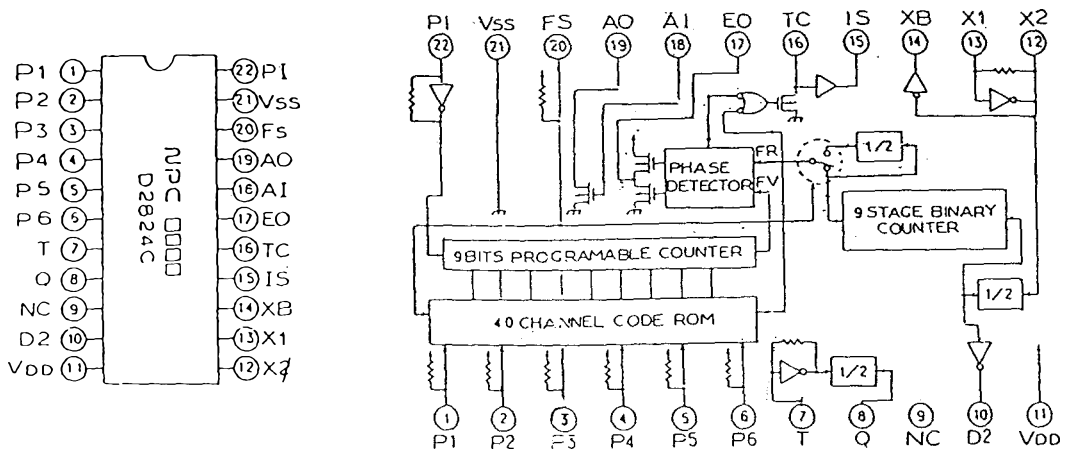

# CIRCUITS INTEGRES

M5223L

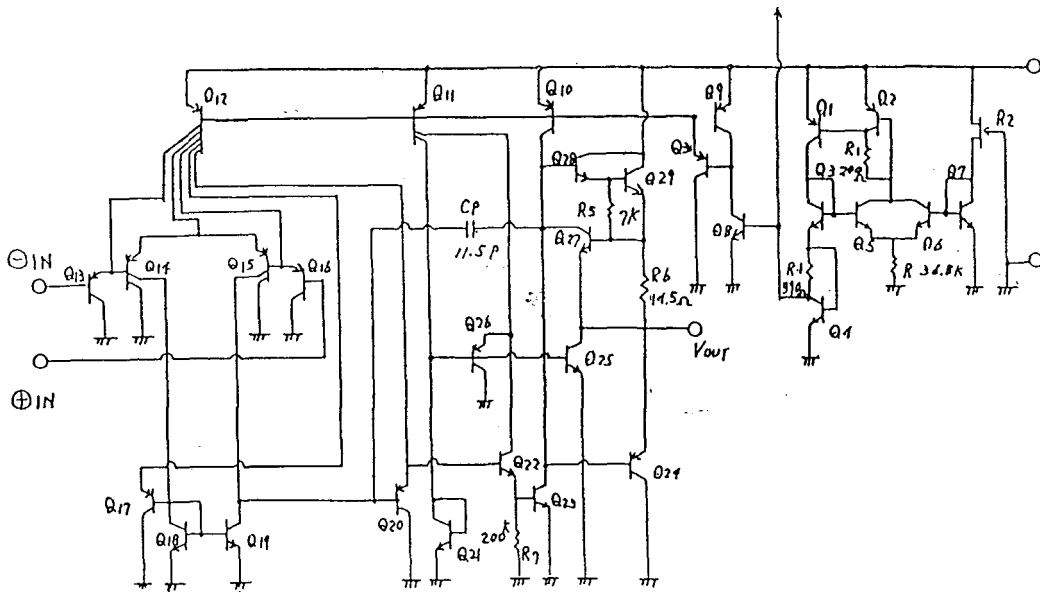
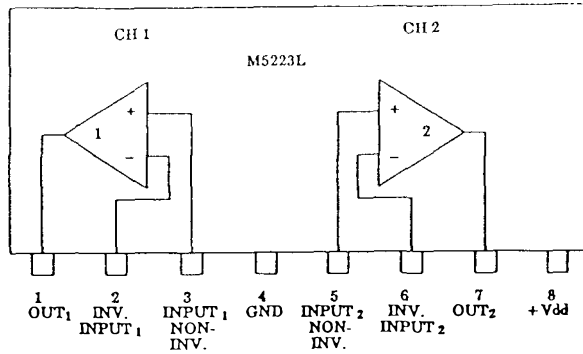

TA7320P  
BALANCED MODULATOR-DEMODULATOR

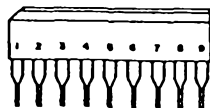
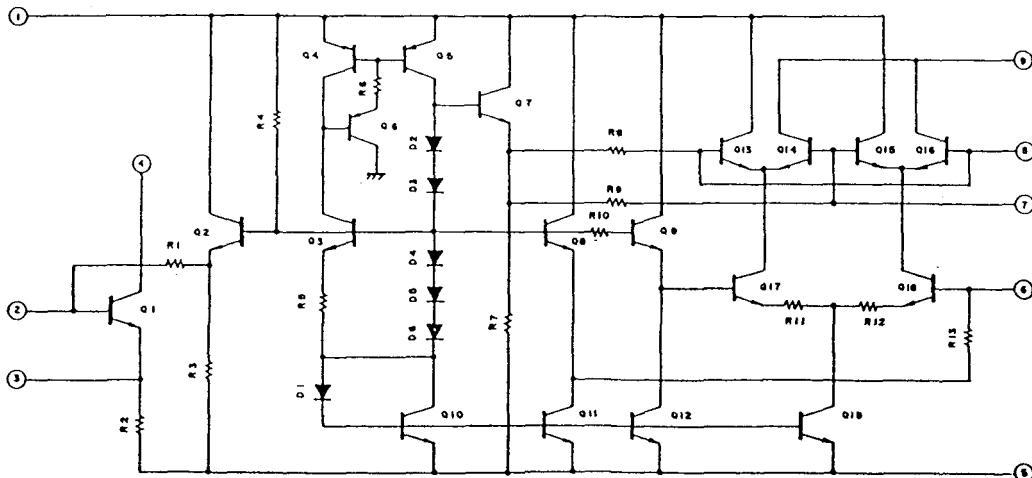

# CIRCUITS INTEGRES

μPC1242H

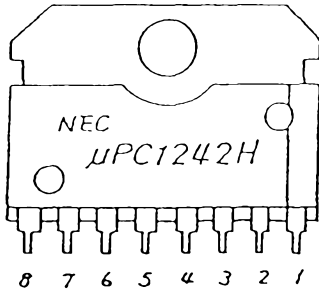

Terminal No	μPC1242H
1	IN
2	Ripple filter
3	N.F.B.
4	GND
5	GND
6	OUT
7	Bootstrap
8	V <sub>dd</sub>

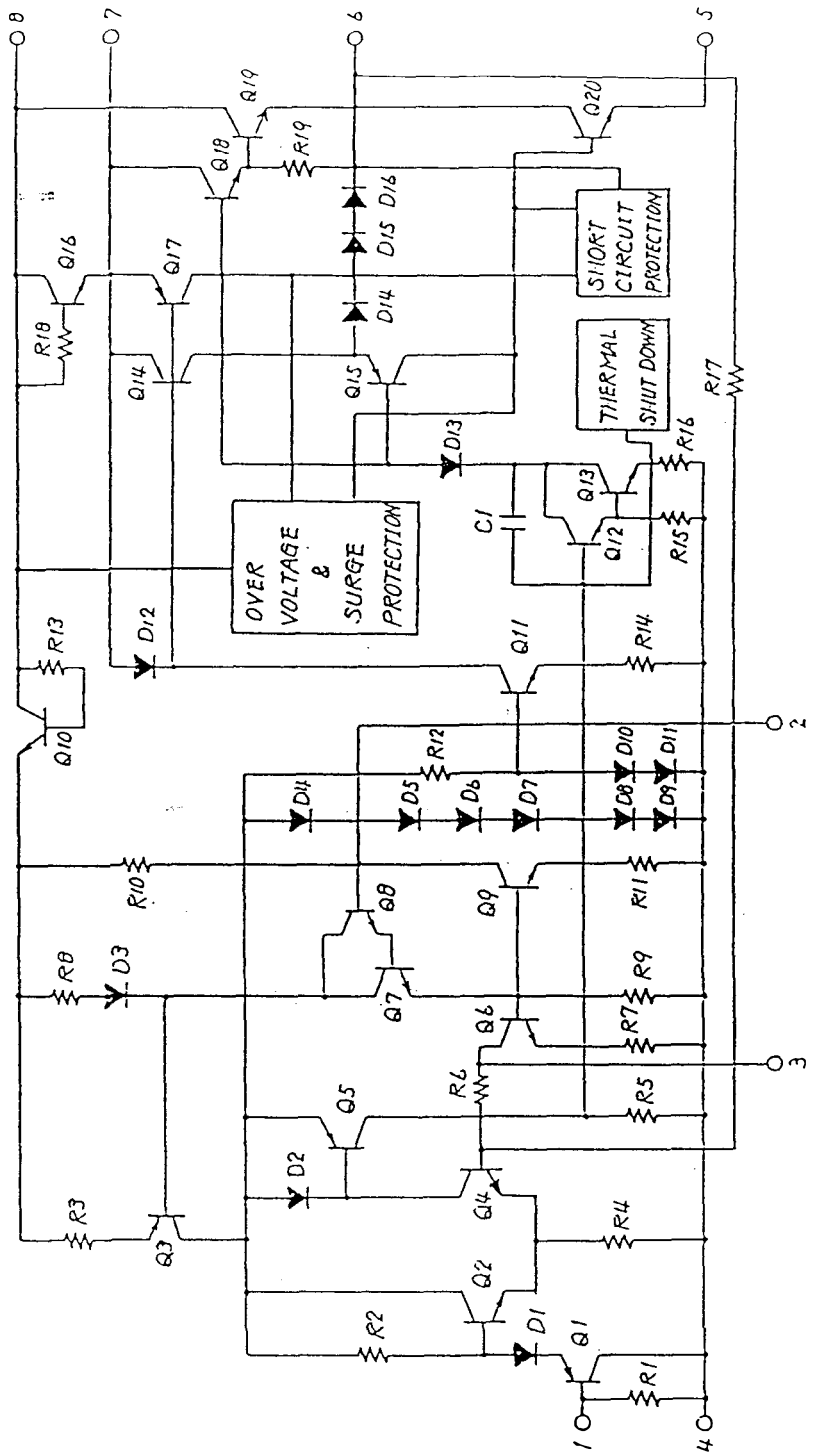



CS51	0.0047/TF
CS52	0.0047/TF
CS53	0.0115N1
SS51	SV462
SS52	SV462
SS53	SV462
SS54	SV462

OS51	LL-2253YL
OS52	CL9H04
OS53	CL9H04
OS54	1S1555
OS55	1S1555
OS56	1S1555
OS57	1S1555
OS58	1S1555
OS59	1S1555
OS60	1S1555

JP551	5
JP552	7.5
JP553	10
JP554	7.5
JP555	10
JP556	15
JP557	5
JP558	5
JP559	7.5
JP560	5
JP561	17.5
JP562	5

PL551	P2027
PL552	P2027
LS51	L0099
LS52	L0077
LS53	L0077

RS51	
RS52	
RS53	
RS54	
RS55	
RS56	
RS57	
RS58	
RS60	
RS61	
RS62	
RS63	
RS64	
RS65	
RS66	

RS51 P0-123AA 1/2

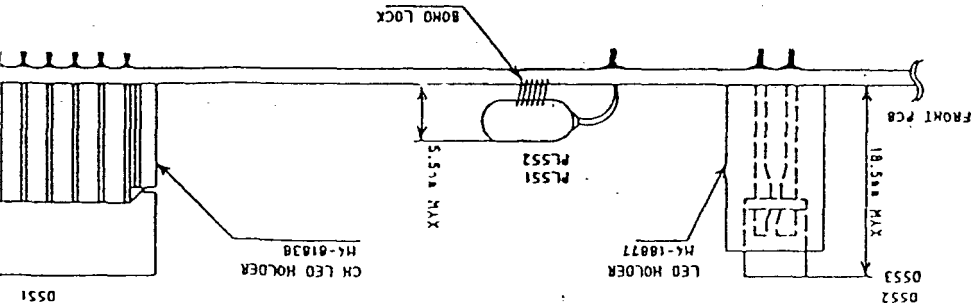
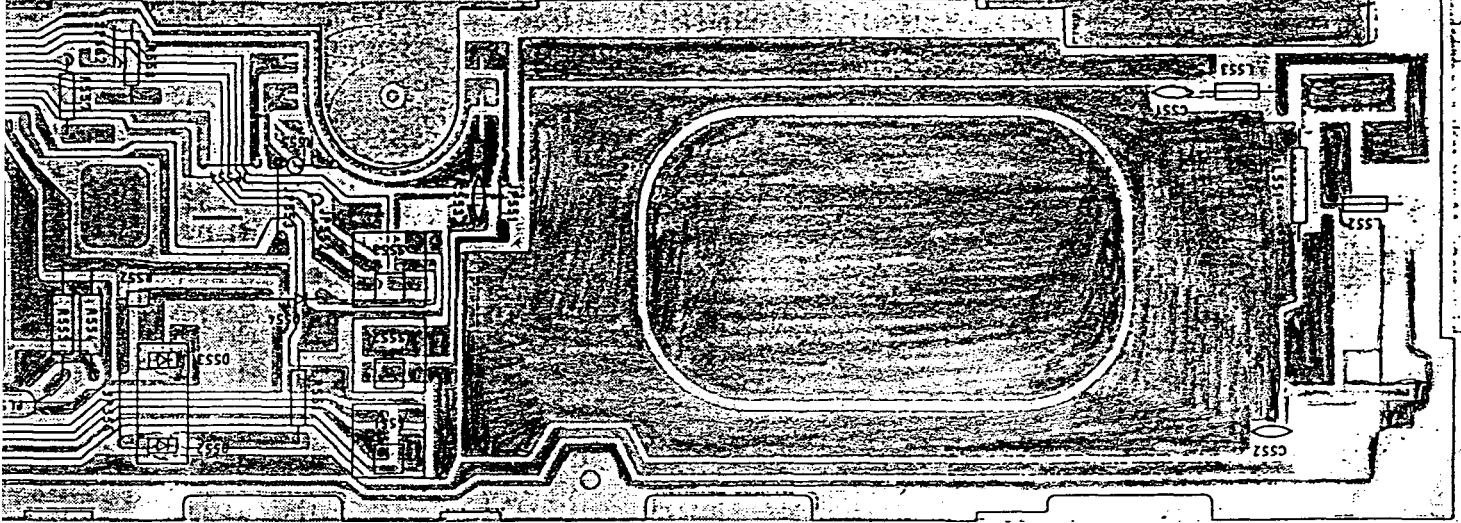

7B

7C

7B 7C

# PLATINE COMM

UT552/PB12

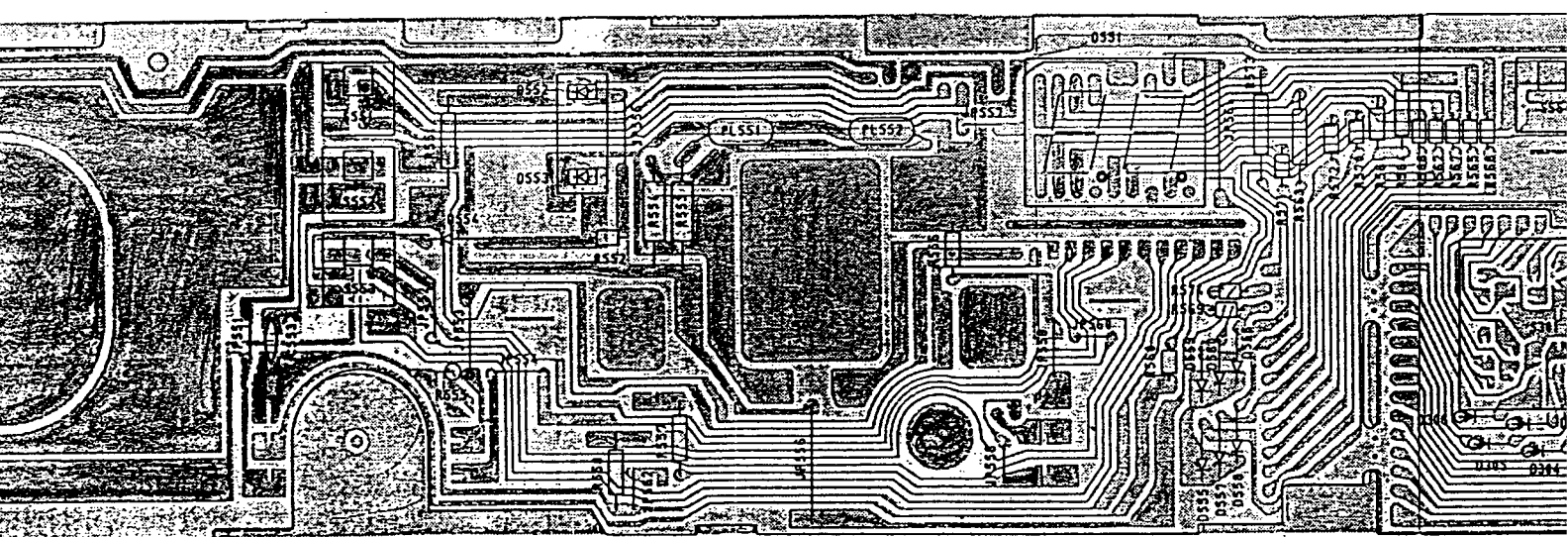
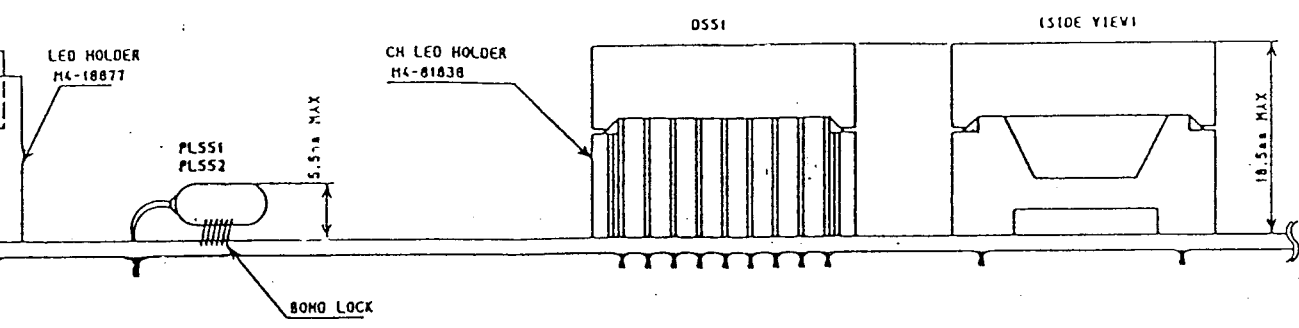

8301j PB-123AA 2/2

S51	LL-2253YL
S52	GL9H04
S53	GL9H04
S54	1S1555
S55	1S1555
S56	1S1555
S57	1S1555
S58	1S1555
S59	1S1555
S60	1S1555

JP551	5
JP552	7.5
JP553	10
JP554	7.5
JP555	10
JP556	15
JP557	5
JP558	5
JP559	7.5
JP560	5
JP561	17.5
JP562	5

L551	L0099
L552	L0077
L553	L0077
PL551	P2027
PL552	P2027

R551	820
R552	390
R553	12 1/2W
R554	12 1/2W
R555	22K
R556	2.2K
R557	2.2K
R558	1.8K
R560	22K
R561	560
R562	560
R563	560
R564	560
R565	560
R566	560

R567	560
R568	560
R569	560
R570	560
R571	560
R572	560
R573	560
R574	560

O301	1S1555
O302	1S1555
O303	1S1555
O304	1S1555
O305	1S1555
O306	1S1555
S301	SR241

NOTES:  
1. RESISTOR  
OTHERWISE  
2. RESISTOR  
POWER  
3. CAPACITY  
UNLESS

7C

7D

# PLATINE COMMUTATEUR DE CANAUX

UT552/PB123AA : : 52 : 1

(SIDE VIEW)

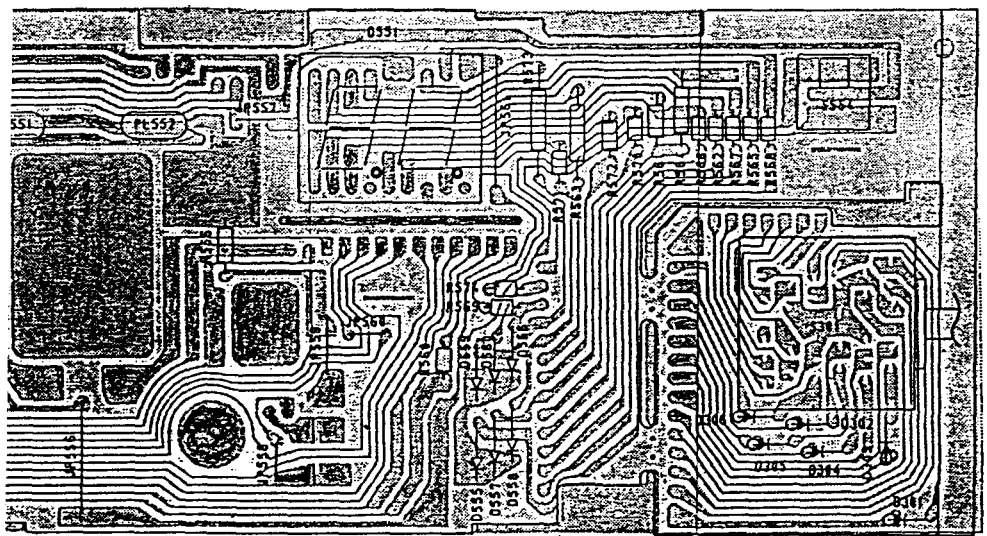
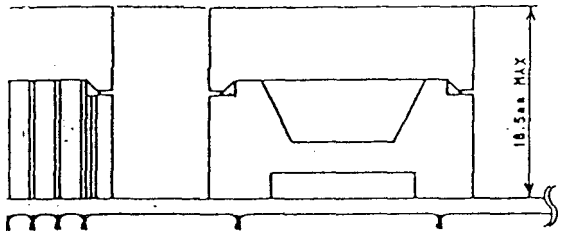

8301j PB-123AA 2/2

820
390
12 1/2W
12 1/2W
22K
2.2K
2.2K
1.8K
22K
560
560
560
560
560

R567	560
R568	560
R569	560
R570	560
R571	560
R572	560
R573	560
R574	560

0301	1S1555
0302	1S1555
0303	1S1555
0304	1S1555
0305	1S1555
0306	1S1555
S301	SR241

NOTES:  
 1. RESISTANCE VALUES ARE SHOWN IN OHMS UNLESS OTHERWISE NOTED. (E=10<sup>0</sup>, D=10<sup>1</sup>, M=10<sup>3</sup>, G=10<sup>6</sup>)  
 2. RESISTOR WATTAGES ARE 1/2W UNLESS OTHERWISE NOTED.  
 3. CAPACITANCE VALUES ARE INDICATED IN MICRO FARADS UNLESS OTHERWISE NOTED. (P=PICO-MICRO FARAD)

TITLE FRONT CH. SV PCB  
 PARTS ASSY TOP VIEW  
**E22-7154**  
 UNIDEN CORP.

8A

8B

B801 PA-241AB

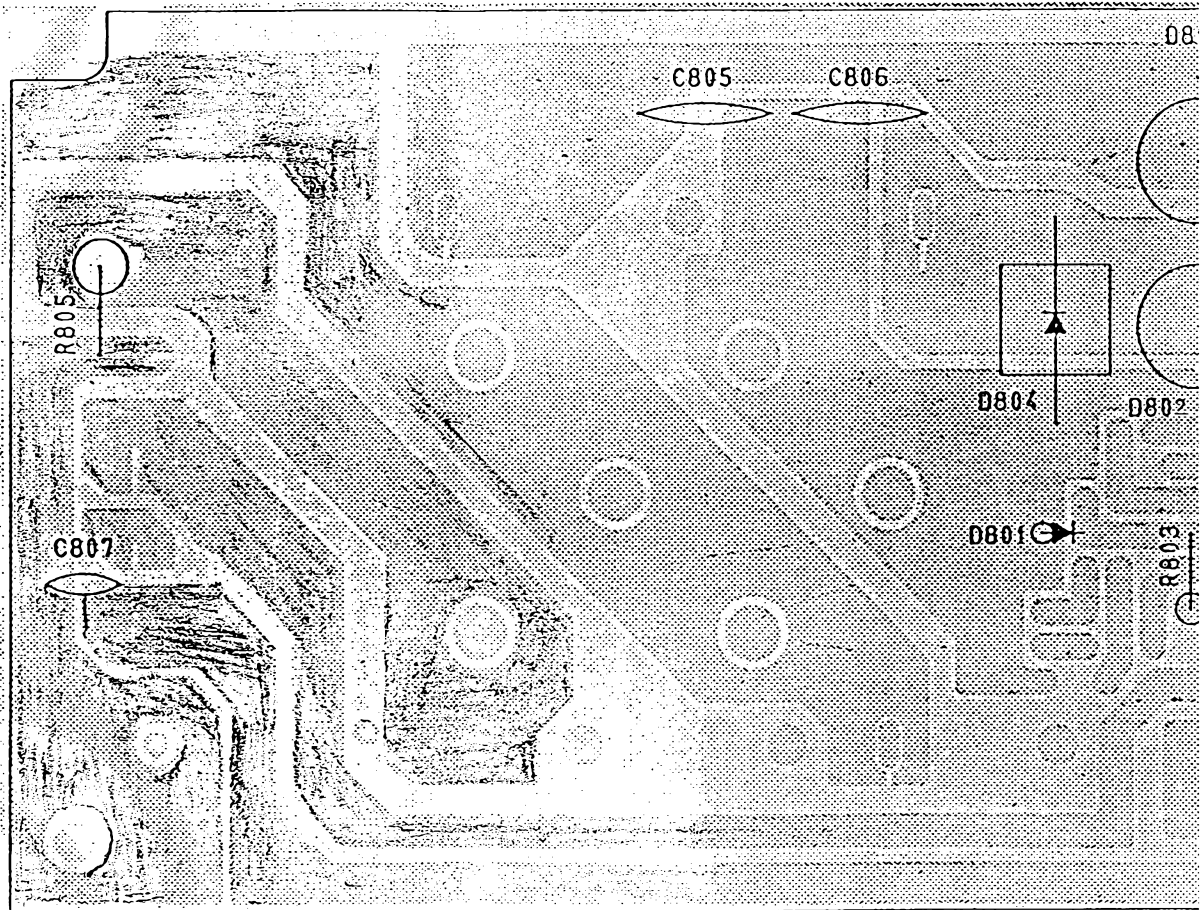



8c

8D

# PLATINE ALIMENTATION

C801	0.047/YF
C802	25V 33 C-174
C803	0.047/YF
C804	35V 3300 CZ149
C805	0.01/YD
C806	0.01/YD
C807	0.0047/YF
C808	0.047(P1)

R801	330
R802	330
R803	1K
R804	3.3K 1/2W
R805	2.2M 1/2W

VR801	200 B RT-182

D801	HZ6C2
D802	6A1
D803	6A1
D804	6A1
D805	6A1

F801	FS023 250V 3A

J801	PG056(2P)

JP801	(10)
JP802	(17.5)

Q801	2SC945AQ
Q802	2SD1348-R

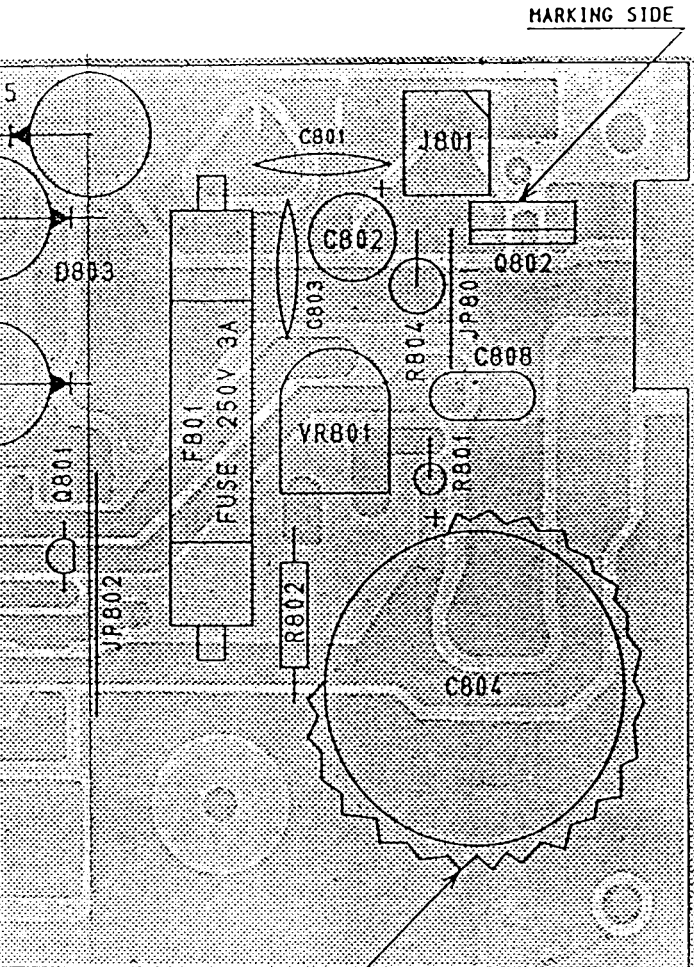

- NOTES:
1. RESISTANCE VALUES ARE SHOWN IN OHMS UNLESS OTHERWISE NOTED. 1K-KILO OHM. M-MEG OHM
  2. RESISTOR WATTAGES ARE 1/8W UNLESS OTHERWISE NOTED.
  3. CAPACITANCE VALUES ARE INDICATED IN MICRO FARADS UNLESS OTHERWISE NOTED. 1P-MICRO-MICRO FARAD

TITLE PWR SUPPLY PCB PARTS ASSE'Y TOP VIEW	
E23-7155	REV. MARK

UNIDEN CORP.



9A

9B

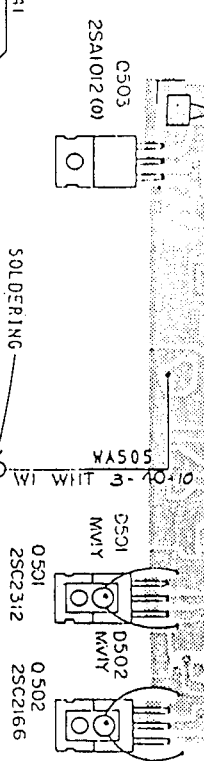
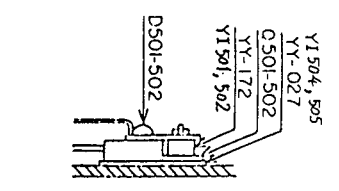
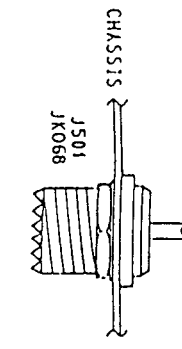
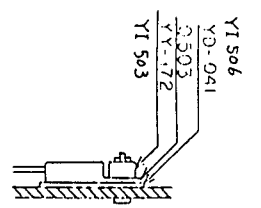
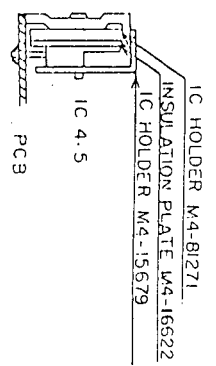

WA504 WZ674

WA503 WZ-673

B001 PA-122 (TOP1) MAIN PCB

FC 007 WF079 3-160-K  
 FC 006 WF 084 3-100-K  
 FC 005 WF 083 3-100-K  
 FC 004 WF 081 3-120-K  
 FC 003 WF 081 3-70-K  
 FC 002 WF 081 3-100-K

FC 001 WF 085 3-220-K

B551 PA-123 1/2 (TOP1) FRONT PCB

S301 SR-241

B301 PA-123 2/2 (TOP1) PCB

FC 008 WF 085 K-90-3

VR503 RV-580

B701 PB-125(BOTTOM) SR PCB

VR504 RV-645

VR502 RV-643

VR501 RV-642

SOLDERING

ORG  
BLU

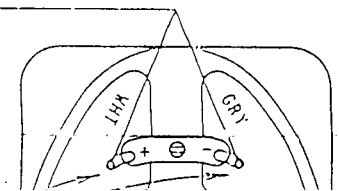

9B 9C

# SCHEMA I

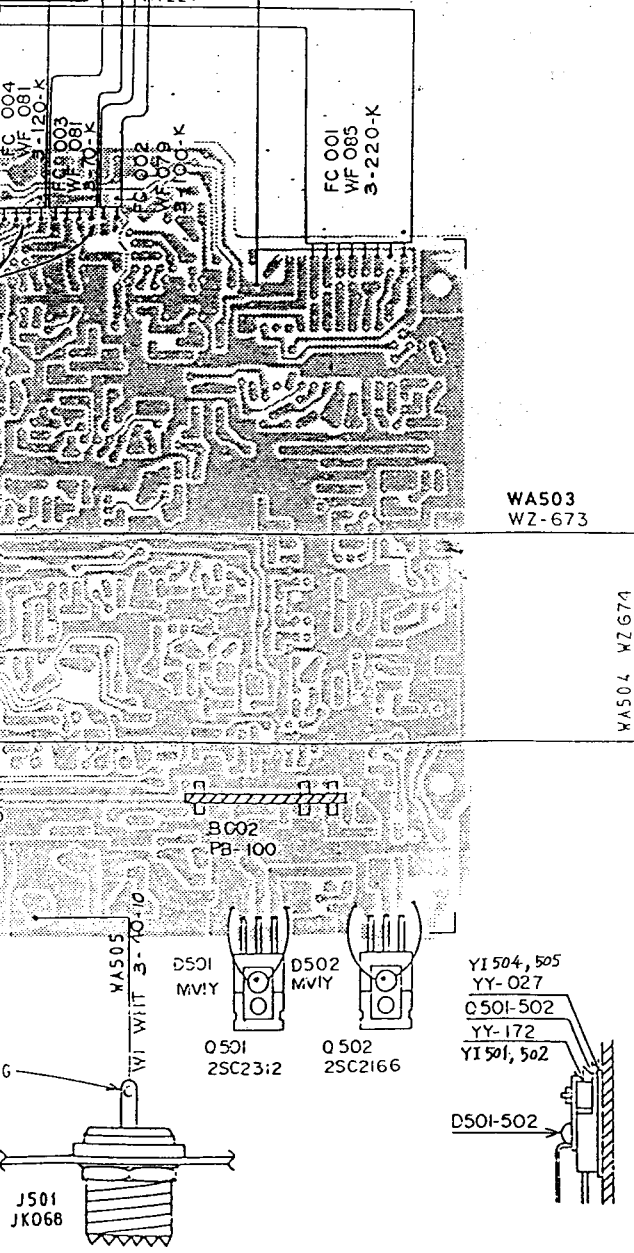
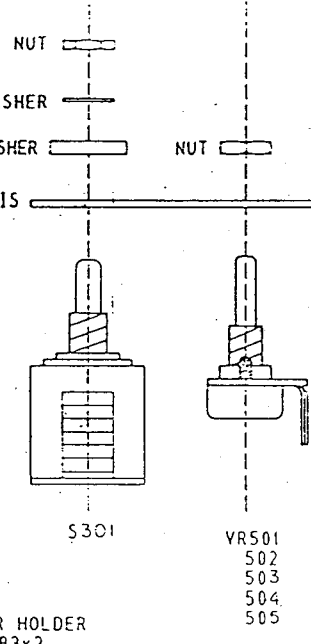
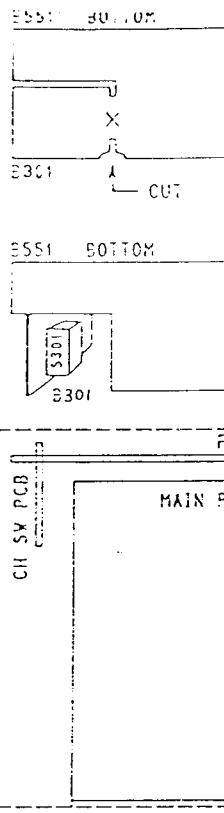
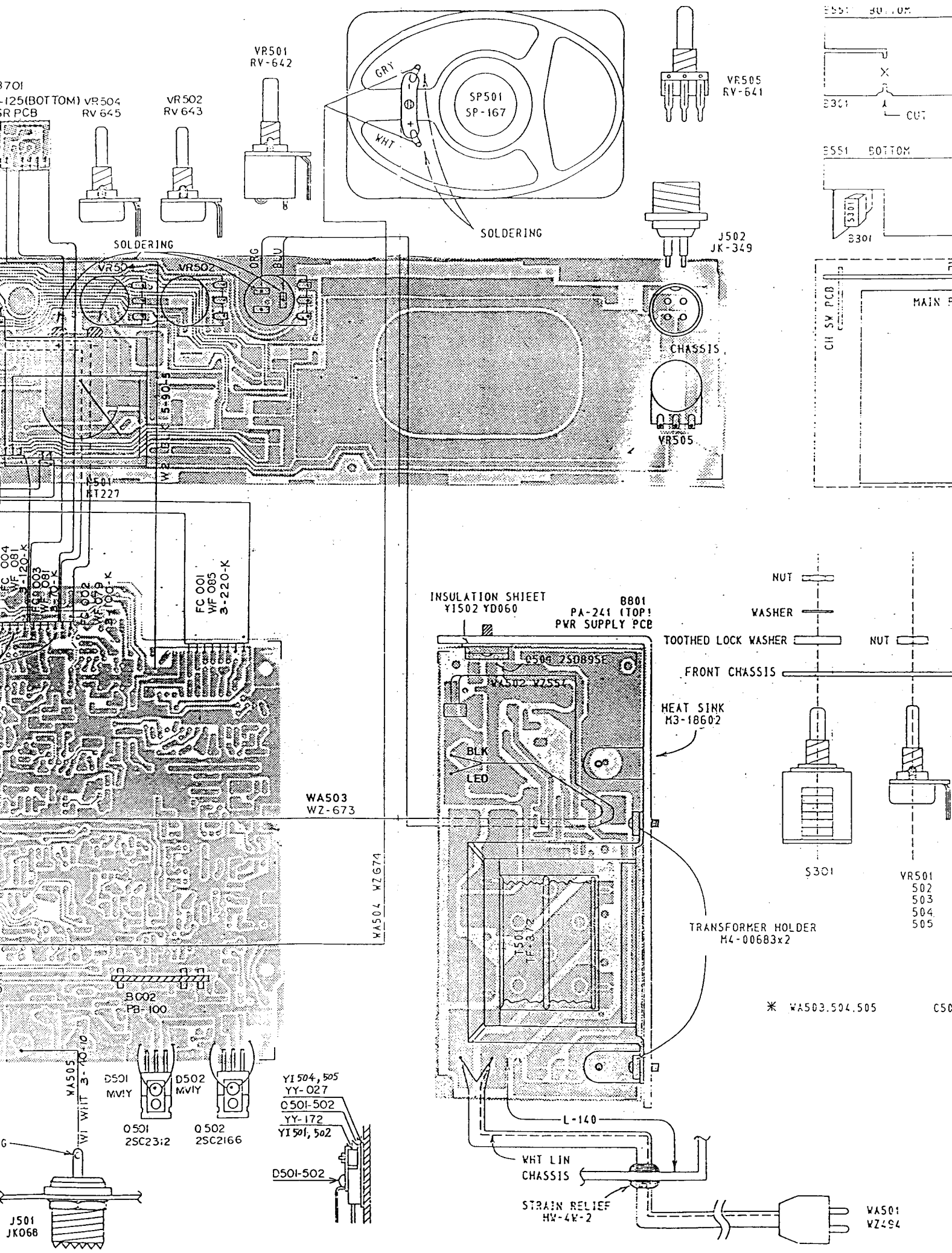



90

# SCHEMA DE CABLAGE

90

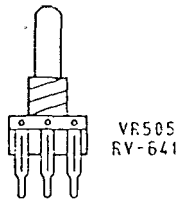
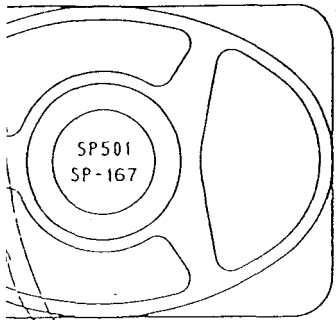

SOLDERING

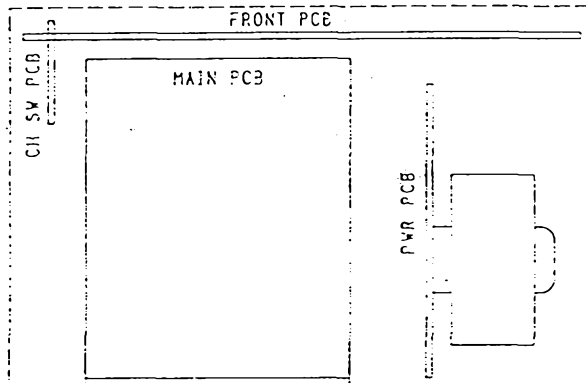
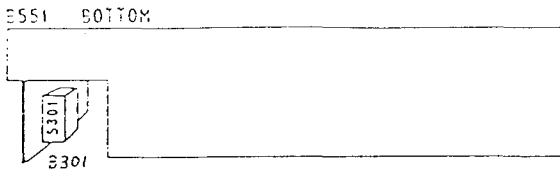
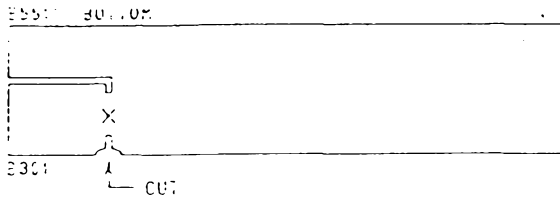
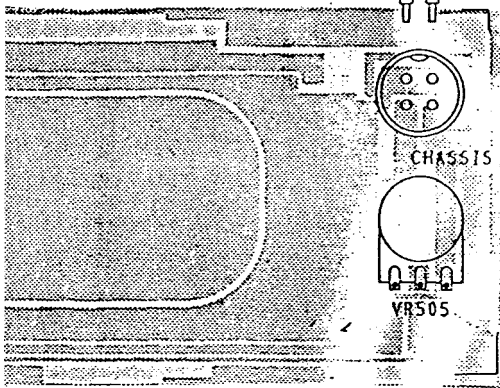
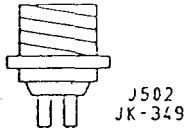

INSULATION SHEET  
Y1502 YD060

8801  
PA-241 (TOP)  
PWR SUPPLY PCB

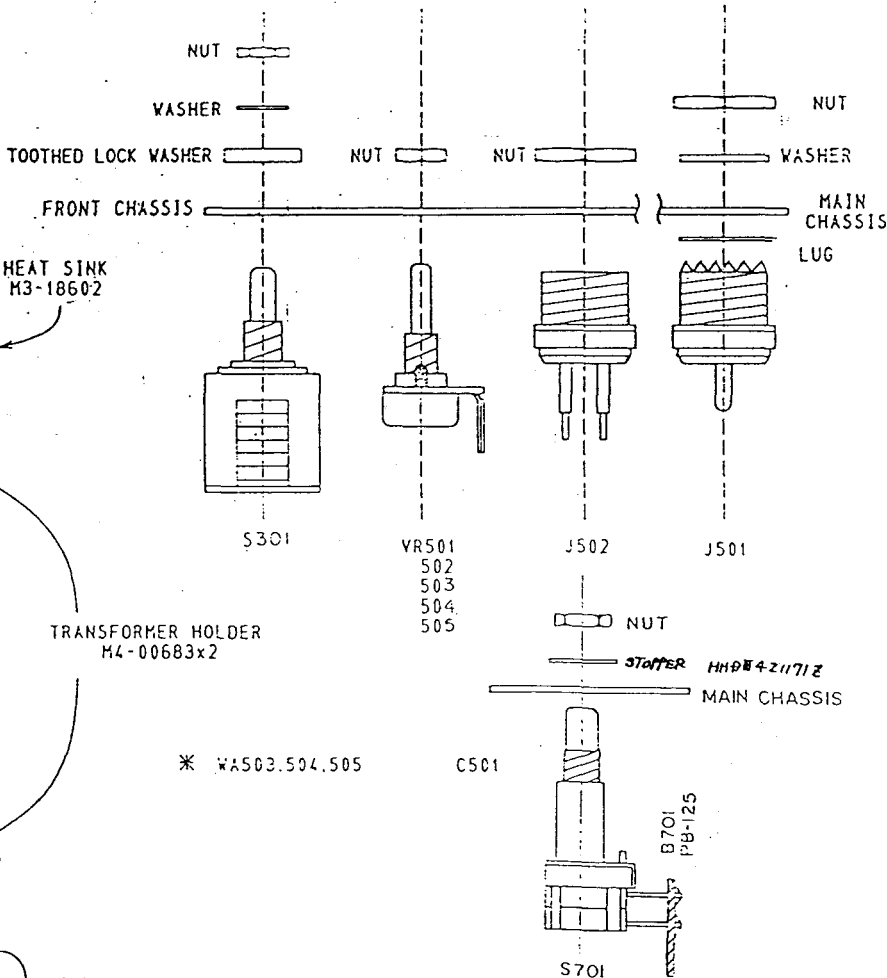
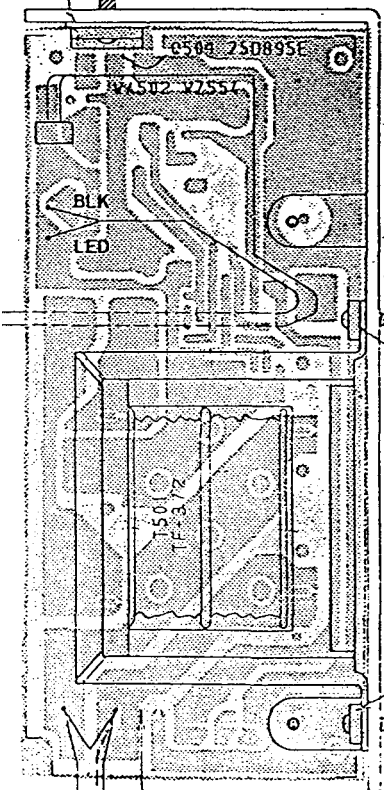

\* WA503.504.505

C501

L-140

WHT LIN CHASSIS

STRAIN RELIEF HW-4K-2

WA501  
WZ4S4

TITLE  
WIRING DIAGRAM

DRAWING NO. E32-2801

REV. WASE

UNIDEN CORP.

# PLATINE PRINCIPALE

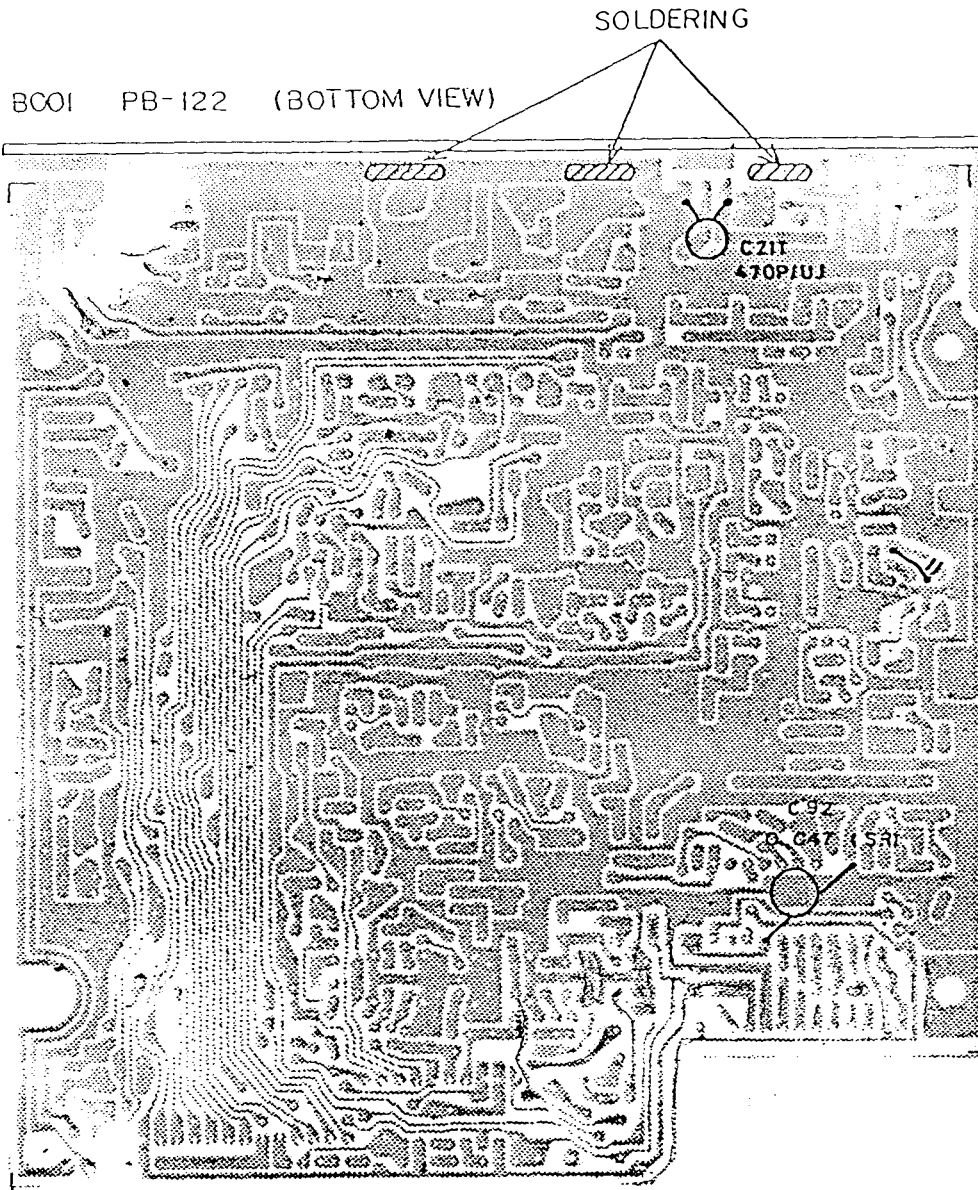

## LISTE PIECES DETACHEES BENJAMIN

1

	REF.	DESIGNATION	QTE/MOD.
	BC002	BOBINE LD-077	2
	BC003	BOBINE LD-087	4
	BC037	BOBINE LD-099	1
	BC167	BOBINE LZ-035 470UH	4
*	BR015	BOBINE LB-137	2
*	BR016	BOBINE LB-209	2
	BR027	BOBINE LB-339	1
*	BR030	BOBINE LB-342	2
	BR177	BOBINE LB-438	1
	BR178	BOBINE LB-452	1
	BR179	BOBINE LB-440	1
	BR180	BOBINE LB-451	2
	BR181	BOBINE LB-464	1
	BT022	TRANSFORMATEUR TF-422	1
*	DC009	DIODE MV-1Y	2
	DC022	DIODE 1S V73-EB/1S 2688 FA	1
	HP023	HAUT-PARLEUR SP-167	1
	I0008	CIRCUIT INTEGRE L 7808	1
**	IP018	CIRCUIT INTEGRE UPC 1242 H	1
**	IR000	CIRCUIT INTEGRE M 5223L	1
*	IR001	CIRCUIT INTEGRE AN 612	1
**	IR007	CIRCUIT INTEGRE TA 7320-P	1
	IS032	CIRCUIT INTEGRE D 2824C	1
*	JX001	JACK JK-089 HP EXTERNE	1
	OA022	AFFICHEUR LL-2253 BENJAMIN	1
*	PQ024	QUARTZ 10.6975 UND	1

## LISTE PIECES DETACHEES BENJAMIN

2

REF.	DESIGNATION	QTE/MOD.
PQ048	QUARTZ 10.2417	1
QX195	FACE AVANT	1
QX196	PLAQUE COMMANDE BENJAMIN	1
QX197	BOUTON POUSSOIR NOIR	4
QX198	BOUTON ROND CANAUX NOIR	1
QX199	BOUTON ROND NOIR	5
QX200	BOUTON ROND M.GAIN NOIR	1
QX201	PLAQUE AFFICHEUR BENJAMIN	1
RV089	POTENTIOMETRE.RV-642 VOL/M/A	1
RV090	POTENTIOMETRE.RV-643 SQUELCH	1
RV091	POTENTIOMETRE.RV-680 10KB/CLAR	1
RV092	POTENTIOMETRE.RV-645 1KB/M.GAI	1
RV093	POTENTIOMETRE.RV-641 1KA/RF.G	1
SS034	COMMUTATEUR SR-241/CANAUX	1
* SX026	COMMUTATEUR SW-462/CONTACT 2 P	4
SX075	COMMUTATEUR SR-406/MODE 3P	1
* TB003	TRANSISTOR 2SA 1012	1
* TH001	TRANSISTOR 2SC 2166	1
*** TH002	TRANSISTOR 2SC 2312	1
TX001	TRANSISTOR 2SA 733	2
TX002	TRANSISTOR 2SC 945	16
TX003	TRANSISTOR 2SC 1674	2
TX004	TRANSISTOR 2SC 1675	2
* TX005	TRANSISTOR 2SC 1730	2
* TX007	TRANSISTOR 2SC 1973-SSB	1
TX117	TRANSISTOR 2SC 3242	2

## LISTE PIECES DETACHEES BENJAMIN

3

REF.	DESIGNATION	QTE/MOD.
TX309	TRANSISTOR 2SB 1035	2
TX310	TRANSISTOR 2SD 895	1
TX311	TRANSISTOR 2SD 1348	1
VM015	VU-METRE MT-227	1

Pièces détachées Spécifiques à chaque Appareil			
EMETTEUR/RECEPTEUR	P.A. amplificateur de puissance.	P.L.L. boucle à verrouil- lage de phase	R.F. Basses Fréquences
JIMMY	2SC 2166	SM 5124	TDA 1905
JOHNNY	2SC 2166	SM 5124	TDA 1905
HARRY	2SC 2166	SM 5124	TDA 1905
TAYLOR	2SC 2029	TC 9106/SM 5126C	MB 3712
FRANCOIS	2SC 2029	TC 9109/SM 5126A	MB 3712
VALERY	2SC 2029	TC 9106/SM 5126C	MB 3712
WILSON	2SC 2166	SM 5124	UFC 1242
HERBERT	2SC 2166	TC 9106	UFC 1242
SS-120	2SC 1944	UPD 2816	TA 7222
JACK	2SC 2312	MB 8719	* UFC 1242
GRANT	2SC 2312	MB 8719	* UFC 1242
J.F.K.	2SC 1944	UPD 2816	MB 3712
SS-360	2SC 2312	MC 145106	TA 7222
JACKSON	MRF 477	MC 145106	* UFC 1242
LINCOLN	MRF 477	PLL 0305	TDA 1905
BENJAMIN	2SC 2312	D 2824	UFC 1242
WILLIAM	2SC 2166	SM 5125	TDA 2822
MC 6700	2SC 1946	MB 8789	TA 7066 (combiné) MB 3713 (H.F.)

CONTACTER NOTRE S.A.V. concernant nos Conditions, Disponibilité et Tarif.

\* Ces appareils utilisaient sur les anciens modèles en B F : UFC 1182

# PRESIDENT

ELECTRONICS EUROPE

PIECES DETACHEES

COMMUNES A PLUSIEURS APPAREILS

Ref. CIRCUIT BF	EMETTEUR/RECEPT .	Ref. P.A	EMETTEUR/RECEPTEUR
MB 3712	TAYLOR FRANCOIS VALERY J.F.K (2)	2SC 2166	JOHNNY  HERBERT WILSON HARRY
TDA 1905	HARRY-JIMMY PC-33 LINCOLN JOHNNY		WILLIAM  JIMMY
UPC 1242	GRANT JACKSON JACK HERBERT BENJAMIN		PC-33X
TDA 2822	WILLIAM	2SC 2029	TAYLOR FRANCOIS VALERY PC 33 /43
TA 7222	SS-120 / ROBERT SS-360 / RICHARD RONALD FRANKLIN	2SC 1944	SS-120 J.F.K
TA 7066	MC-6700 (combiné)	2SC 2312	SS-360 GRANT JACK RONALD FRANKLIN BENJAMIN
MB 3713	MC-6700 ( H.F. )		
UPC 1182	JACK ancien GRANT modèle JACKSON	MRF 477	JACKSON LINCOLN
AFFICHEUR		MANUELS MAINTENANCE	
UR 202	VALERY SS-120 JFK SS-360 GRANT JACKSON JACK	LAMPES VU-METRE	TOUS MODELES  TOUS MODELES

VU-METRE

COMMUTATEUR

POTENTIOMETRE

QUARTZ

Spécifique à chaque appareil

CONTACTER NOTRE S.A.V. concernant nos Conditions. Disponibilité et Tarif.

## PIECES DETACHEES

## COMMUNES A PLUSIEURS APPAREILS

Ref. P L L	EMETTEUR/RECEPT	Ref. HAUT-PARLEUR	EMETTEUR/RECEPT.
SM 5124	HARRY - JIMMY JOHNNY WILSON	SF 057/SF 227	VALERY TAYLOR FRANCOIS JACK PC 33X /43
TC 9106	TAYLOR PC-33/43/44 HERBERT	SF 053	SS-360 GRANT JACKSON
TC 9109	FRANCOIS VALERY	SF 052	JFK SS-120
UPD 2816	SS-120/ROBERT JFK	SF 154/SF 169	HARRY JIMMY JOHNNY WILSON
MB 8719	GRANT JACK	SF 149	HERBERT
MC 145106	SS-360/RICHARD JACKSON RONALD FRANKLIN		
FLL 0305	LINCOLN		
D 2824	BENJAMIN		
MB 8789	MC 6700		
SM 5125	WILLIAM		

CONTACTER NOTRE S.A.V. concernant nos Conditions, Disponibilité et Tarif



# PRESIDENT

ELECTRONICS EUROPE

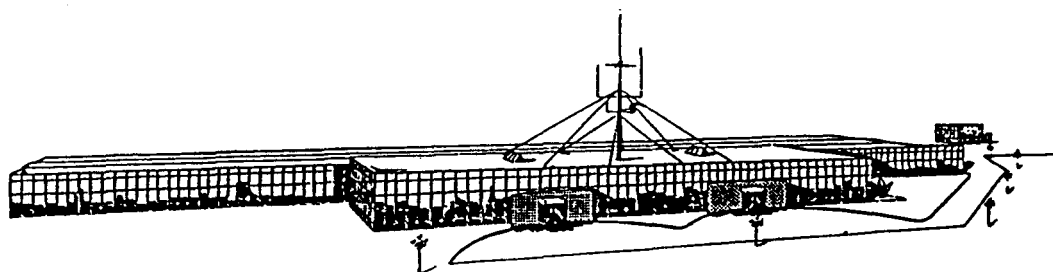

**SIEGE SOCIAL - FRANCE**  
Route de SETE - BP 100  
34540 BALARUC - Tél : 67.46.27.27  
Télex : 490534F - Fax : 67.48.48.49

**SUCCURSALE "ILE DE FRANCE"**  
50/56, rue du Pré des Aulnes  
Parc d'activités des Arpents  
77340 PONTAULT-COMBAULT  
Tél : (1) 60.29.28.27 - Fax : (1) 60.28.44.00



**VENTE EXCLUSIVE AUX DISTRIBUTEURS - 2 SUCCURSALES A VOTRE SERVICE**

**S.A. CAPITAL 20.000.000 F.F. - SIREN SETE 315 230 490**