

## DAB One-Chip Front End



### Description

The U2731B is a monolithically integrated DAB one-chip front end circuit manufactured using Atmel Wireless & Microcontrollers' advanced UHF5S technology. Its functionality covers a gain-controlled RF amplifier with two selectable RF inputs, a gain-controlled RF mixer, a VCO which provides the LO signal for the RF mixers, either directly or after passing a frequency divider, a SAW filter driver, an AGC block for the RF section, a gain-controlled IF amplifier, an IF mixer which can also be bypassed, an AGC block for the IF section and a fractional-N frequency synthesizer. The frequency synthesizer controls the VCO to synthesize frequencies in the range of 70 MHz to 500 MHz in a 16-kHz raster; within certain limits the reference divide factor is fully programmable. The lock status of the phase detector is

indicated at a special output pin; three switching outputs can be addressed. A reference signal which is generated by an on-chip reference oscillator is available at an output pin. This reference signal is also used to generate the LO signal for the IF mixer, either by doubling the frequency or by using the reference frequency itself. Three D/A converters at a resolution of 8 bits provide a digitally controllable output voltage. The thresholds inside the AGC blocks can be digitally controlled by means of on-chip 4-bit D/A converters. All functions of this IC are controlled by the I<sup>2</sup>C bus.

Electrostatic sensitive device.

Observe precautions for handling.



### Features

- 8.5 V supply voltage
- Voltage regulator for stable operating conditions
- Microprocessor controlled via an I<sup>2</sup>C bus
- 4 addresses selectable
- Gain-controlled RF amplifier with two inputs, selectable by I<sup>2</sup>C-bus control
- Balanced RF amplifier inputs
- Gain-controlled RF mixer
- Four-pin voltage-controlled oscillator
- SAW filter driver with differential low-impedance output
- AGC voltage generation for RF section, available at charge-pump output (can also be used to control a PIN diode attenuator)
- Gain-controlled IF amplifier
- Balanced IF amplifier inputs
- Selectable gain-controlled IF mixer
- Single-ended IF output
- AGC voltage generation for IF section, available at charge-pump output
- Separate differential input for the IF AGC block
- All AGC time constants adjustable
- AGC thresholds programmable via the I<sup>2</sup>C bus
- Three AGC charge pump currents selectable (zero, low, high)
- Reference oscillator
- Programmable 9-bit reference divider
- Programmable 15-bit counter 1:2048 to 1:32767 effectively
- Tristate phase detector with programmable charge pump
- Superior phase-noise performance
- Deactivation of tuning output programmable
- 3 switching outputs (open collector)
- 3 D/A converters (resolution: 8 bits)
- Lock status indication (open collector)

### Ordering Information

Extended Type Number	Package	Remarks
U2731B-MFN	SSO44	Tube
U2731B-MFNG1	SSO44	Taped and reeled

## Block Diagram

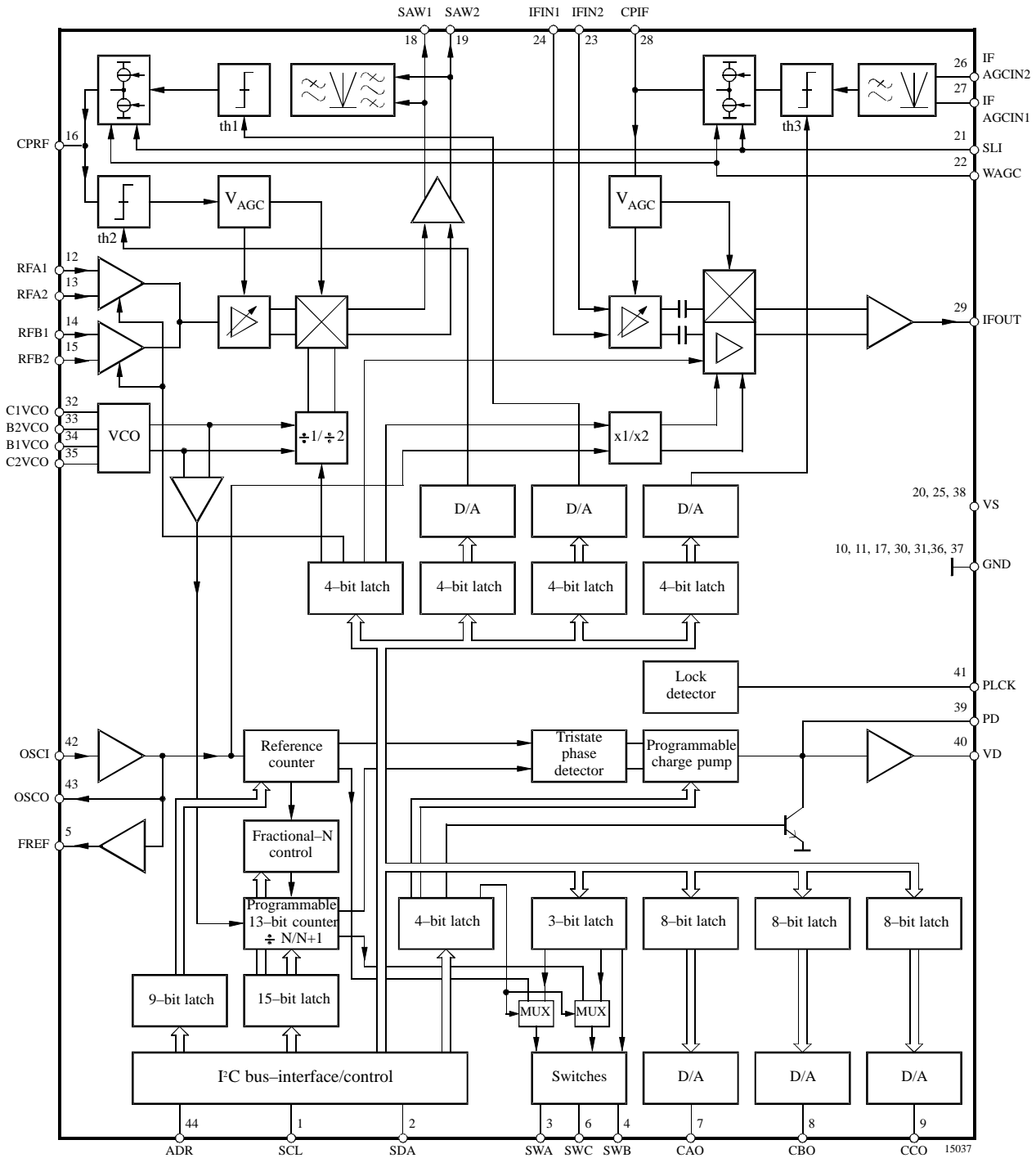
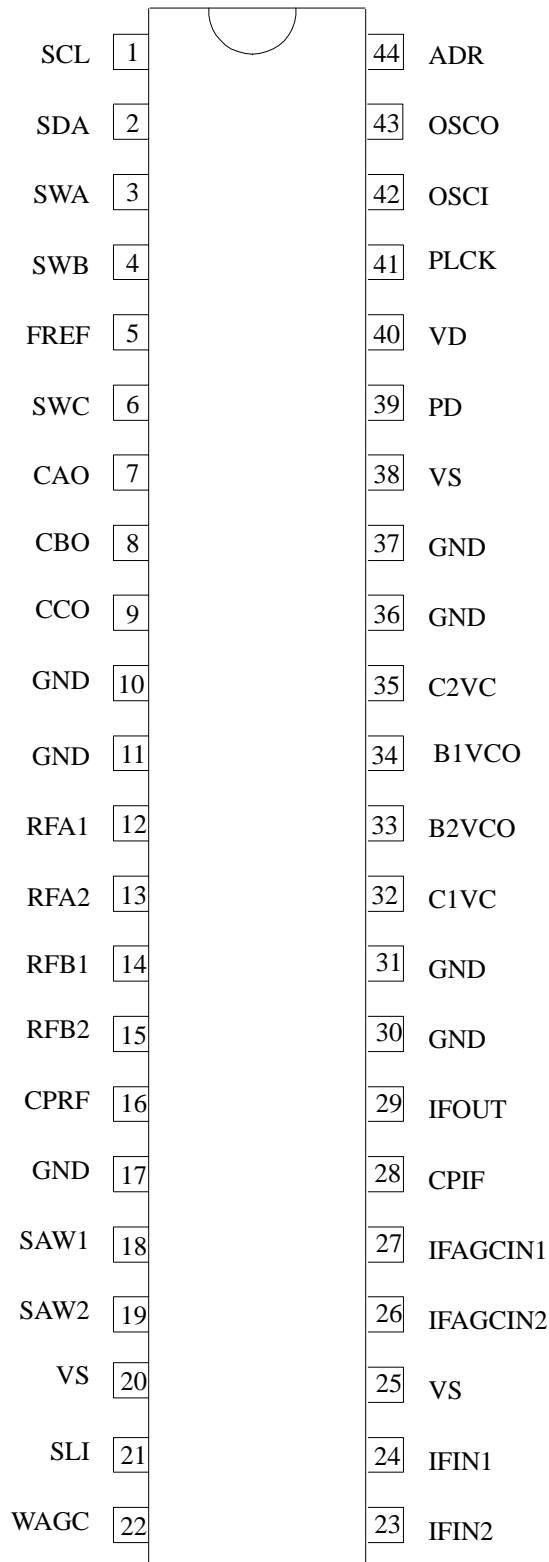

Figure 1. Block diagram

## Pin Description



14855

Figure 2. Pinning

Pin	Symbol	Function
1	SCL	Clock (I <sup>2</sup> C bus)
2	SDA	Data (I <sup>2</sup> C bus)
3	SWA	Switching output (open collector)
4	SWB	Switching output (open collector)
5	FREF	Ref. frequency output (for U2730B)
6	SWC	Switching output (open collector)
7	CAO	Output of D/A converter A
8	CBO	Output of D/A converter B
9	CCO	Output of D/A converter C
10	GND	Ground
11	GND	Ground
12	RFA1	Input 1 of RF amplifier A (differential)
13	RFA2	Input 2 of RF amplifier A (differential)
14	RFB1	Input 1 of RF amplifier B (differential)
15	RFB2	Input 2 of RF amplifier B (differential)
16	CPRF	Charge-pump output (RF AGC block)
17	GND	Ground
18	SAW1	SAW driver output 1 (differential)
19	SAW2	SAW driver output 2 (differential)
20	VS	Supply voltage
21	SLI	AGC mode selection (charge-pump current high)
22	WAGC	AGC mode selection (charge-pump current off)
23	IFIN2	Input 2 of IF amplifier (differential)
24	IFIN1	Input 1 of IF amplifier (differential)
25	VS	Supply voltage
26	IFAGCIN2	Input 2 of IF AGC block (differential)
27	IFAGCIN1	Input 1 of IF AGC block (differential)
28	CPIF	Charge-pump output (IF AGC block)
29	IFOUT	IF output (single ended)
30	GND	Ground
31	GND	Ground
32	C1VC	Collector 1 of VCO
33	B2VCO	Base 2 of VCO
34	B1VCO	Base 1 of VCO
35	C2VC	Collector 2 of VCO
36	GND	Ground
37	GND	Ground
38	VS	Supply voltage
39	PD	Tristate charge pump output
40	VD	Active-filter output
41	PLCK	Lock-indicating output (open collector)
42	OSCI	Input of reference oscillator/buffer
43	OSCO	Output of reference oscillator/buffer
44	ADR	Address selection (I <sup>2</sup> C bus)

## Functional Description

The U2731B-A represents a monolithically integrated front end IC designed for applications in DAB receivers. It covers RF and IF signal processing, the PLL section and also supporting functions such as D/A converters or switching outputs.

Two RF input ports offer the possibility of handling various input signals such as a down-converted L-band signal or band II and band III RF signals. The high dynamic range of the RF inputs and the use of a gain-controlled amplifier and a gain-controlled mixer in the RF section offer the possibility of even strong RF input signals. The LO signal of the first mixer stage is derived from an on-chip VCO. The VCO frequency is either divided by two or directly fed to the mixer. In this way band II and band III can be covered easily.

In the IF section, it can be selected if the first IF signal is down-converted to a second, lower IF or if it is simply amplified to appear at the IF output. If the down-conversion option is chosen, it can be selected if the LO signal of the IF mixer is directly derived from the reference signal of the PLL, or if it is generated by doubling its frequency. The amplifiers in the IF section are gain-controlled in similar fashion to the RF section.

The RF and the IF part also contain AGC functional blocks which generate the AGC control voltages. The AGC thresholds can be defined by means of three on-chip 4-bit D/A converters.

The frequency of the VCO is locked to a reference frequency by an on-chip fractional-N PLL circuit which guarantees a superior phase-noise performance. The reference frequency is generated by an on-chip crystal oscillator which can also be overdriven by an external signal. Starting from a minimum value, the reference scaling factor is freely programmable.

Three switching outputs can be used for various switching tasks on the front end board. Three 8-bit D/A converters providing an output voltage between 0 and 8.5 V are used to improve the tuning voltages of the tuned preselectors which are derived from the tuning voltage of the VCO.

All functions of this circuit are controlled by an I<sup>2</sup>C bus.

## RF Part

### RF Gain-Controlled Amplifier

In order to support two different channels, two identical input buffers with balanced inputs (RFA1, RFA2; RFB1, RFB2) are integrated. By setting the I<sup>2</sup>C bus bits M0 and M1 (see section 'I<sup>2</sup>C-bus functions'), the active buffer can be selected. The buffers are followed by a gain-controlled amplifier whose output signal is fed to a gain-controlled mixer. The RF amplifiers are capable of handling input signals up to a power of -6 dBm without causing third-order intermodulation components stronger than -40 dBc.

### RF Gain-Controlled Mixer, VCO and LO Divider

The purpose of the RF mixer is to down-convert the incoming signal (band II, band III) to an IF frequency which is typically 38.912 MHz. This IF signal is fed to an AGC voltage-generation block (which is described in the following section) and an output buffer stage. This driver stage has a low output impedance and is capable to drive a SAW filter directly via its differential output Pins SAW1, SAW2. The mixer's LO signal is generated by a balanced voltage-controlled oscillator whose frequency is stabilized by a fractional-N phase-locked loop. An example circuit of the VCO is shown in figure 12. The oscillator's tank is applied to the Pins B1VC, C1VC, B2VC, C2VC as shown in the application circuit in figure 6. Before the VCO's signal is fed to the RF mixer, it has to pass an LO divider block where the VCO frequency is either divided by 1 or 2. The setting of this divider is defined by means of the I<sup>2</sup>C-bus bits M0 and M1 as indicated in the section 'I<sup>2</sup>C-bus functions'. This feature offers the possibility of covering both band II and band III by tuning the VCO frequency in the range between 200 MHz to 300 MHz.

## RF AGC Voltage-Generation Block

In this functional block, the output signal of the RF mixer is amplified, weakly bandpass filtered (transition range: ~8 MHz to ~80 MHz), rectified and finally lowpass filtered. The voltage derived in this ‘power-measurement process’ is compared to a voltage threshold (th1) which can be digitally controlled by an on-chip 4-bit D/A converter. The setting of this converter is defined by means of the I<sup>2</sup>C-bus bits T<sub>Ai</sub> (i = 1, 2, 3, 4). Depending on the result of this comparison, a charge pump feeds a positive or negative current to Pin CPRF in order to charge or discharge an external capacitor. The voltage of this external capacitor can be used to control the gain of an external preamplifier or attenuator stage; Furthermore, it is also used to generate the internal control voltages of an RF amplifier and mixer. For this purpose, the voltage at Pin CPRF is compared to a voltage threshold (th2) which is also controlled by an on-chip 4-bit D/A converter whose setting is fixed by the I<sup>2</sup>C-bus bits T<sub>Bi</sub> (i = 1, 2, 3, 4).

By means of the input Pins WAGC and SLI the current of the RF AGC charge pump can be selected according to the following table:

WAGC	SLI	Charge-Pump Current / μA
HIGH	X	off
LOW	LOW	50 μA (slow mode)
LOW	HIGH	190 μA (fast mode)

The block functionality can be seen in figure 10.

## IF Part

### IF Gain-Controlled Amplifier

The signal applied to the balanced input Pins IFIN1, IFIN2 is amplified by a gain-controlled IF amplifier. The gain-control signal is generated by an IF AGC voltage-generation block which is described in the next section. To avoid offset problems, the output of the gain-controlled amplifier is fed to an amplifier/mixer combination by AC coupling.

### IF Gain-Controlled Amplifier/Mixer Combination

Depending on the setting of the I<sup>2</sup>C-bus bits M2, M3, the output signal of the gain-controlled IF amplifier is either mixed down to a lower, second IF or, after passing an output buffer stage, amplified before it appears at the single-ended output Pin IFOUT. If the down-conversion option is chosen this circuit still offers two possibilities concerning the synthesis of the IF mixers LO signal. This LO signal is derived from the PLL’s on-chip reference oscillator. By means of the I<sup>2</sup>C-bus bits M2, M3, it can be decided whether the reference frequency is doubled before it is given to the mixer’s LO port, or if it is used directly. The gain-control voltage of the amplifier/mixer combination is similar to the gain-controlled IF amplifier generated by an internal gain-control circuit.

### IF AGC Voltage-Generation Block

The purpose of this gain-control circuit in the IF part is to measure the power of the incoming signal at the balanced input Pins IFAGCIN1, IFAGCIN2, to compare it with a certain power level and to generate a control voltage for the IF gain-controlled amplifiers and mixer. This architecture offers the possibility of ensuring an optimal use of the dynamic range of the A/D converter which transforms the output signal at Pin IFOUT from the analog to the digital domain despite possible insertion losses of (anti-aliasing) filters which are arranged in front of the converter. Such a constellation is indicated in the application circuit in figure 6.

The incoming signal at the balanced input Pins IFAGC1, IFAGC2 passes a ‘power-measurement process’ similar to that described in the section ‘RF AGC Voltage-Generation Block’. For flexibility reasons, no bandpass filtering is implemented. The voltage derived in this process is compared to a voltage threshold (th3) which is defined by an on-chip 4-bit D/A converter. The setting of this converter is defined by the I<sup>2</sup>C-bus bits T<sub>Ci</sub> (i = 1, 2, 3, 4). Depending on the result of this comparison, a charge pump feeds a positive or negative current to Pin CPIF in order to charge or discharge an external capacitor. By means of the Pins WAGC and SLI the current of this charge pump can be selected according to the following table:

WAGC	SLI	Charge Pump Current / μA
HIGH	X	off
LOW	LOW	50 μA (slow mode)
LOW	HIGH	190 μA (fast mode)

The block functionality can be seen in figure 11.

## PLL Part

The purpose of the PLL part is to perform a phase lock of the voltage-controlled RF oscillator to an on-chip crystal reference oscillator. This is achieved by means of a special phase-noise-shaping technique based on the fractional-N principle which is already used in Atmel Wireless & Microcontrollers's U2733B frequency synthesizer series. It concentrates the phase detector's phase-noise contribution to the spectrum of the controlled VCO at frequency positions where it does not impair the quality of the received DAB signal. A special property of the transmission technique which is used in DAB is that the phase-noise-weighting function which measures the influence of the LO's phase noise to the phase information of the coded signal in a DAB receiver has zeros, i.e., if phase noise is concentrated in the position of such zeros as discrete lines, the DAB signal is not impaired as long as these lines do not exceed a set limit. For DAB mode I, this phase-noise-weighting function is shown in figure 3:

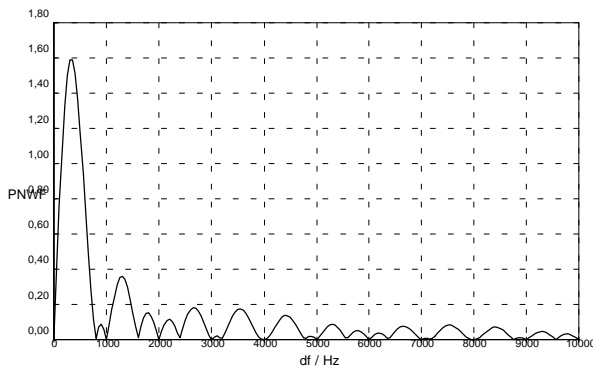

Figure 3.

It is important to realize that this function shows zeros in all distances from the center line which are multiples of the carrier spacing. The technique of concentrating the phase noise in the positions of such zeros is protected by a patent.

## Reference Oscillator

An on-chip crystal oscillator generates the reference signal which is fed to the reference divider. As already described in the section 'IF Gain-Controlled Amplifier/Mixer Combination', the LO signal for the mixer in the IF section is derived. By applying a crystal to the Pins OSCI, OSCO, figure 7, this oscillator generates a highly stable reference signal. If an external reference signal is available, the oscillator can be used as an input buffer. In such an application, see figure 8, the reference signal has to be applied to the Pin OSCI and the Pin OSCO must be left open.

## Reference Divider

Starting from a minimum value, the scaling factor  $SF_{ref}$  of the 9-bit reference divider is freely programmable by means of the I<sup>2</sup>C-bus bits  $r_i$  ( $i = 0, \dots, 8$ ) according to  $SF_{ref} = \sum r_i \times 2^i$ .

If, for example, a frequency raster of 16 kHz is requested, the scaling factor of the reference divider has to be specified in such a way that the division process results in an output frequency which is four times higher than the desired frequency raster, i.e., the comparison frequency of the phase detector equals four times the frequency raster. By changing the division ratio of the main divider from  $N$  to  $N+1$  in an appropriate way (fractional-N technique), this frequency raster is interpolated to deliver a frequency spacing of 16 kHz. So effectively a reference scaling divide factor  $SF_{ref,eff} = 4 \times \sum r_i \times 2^i$  is achieved.

By setting, the I<sup>2</sup>C-bus bit  $T$ , a test signal representing the divided input signal can be monitored at the switching output SWA.

## Main Divider

The main divider consists of a fully programmable 13-bit divider which defines a division ratio  $N$ . The applied division ratio is either  $N$  or  $N+1$  according to the control of a special control unit. On average, the scaling factors  $SF = N + k/4$  can be selected where  $k = 0, 1, 2, 3$ .

In this way, VCO frequencies  $f_{VCO} = 4 \times (N+k/4) \times f_{ref} / (4 \times SF_{ref})$  can be synthesized starting from a reference frequency  $f_{ref}$ . If we define  $SF_{eff} = 4 \times N + k$  and  $SF_{ref,eff} = 4 \times SF_{ref}$  (previous section), then  $f_{VCO} = SF_{eff} \times f_{ref} / SF_{ref,eff}$ , where  $SF_{eff}$  is defined by 15 bits.

In the following, this circuit is described in terms of  $SF_{eff}$  and  $SF_{ref,eff}$ .  $SF_{eff}$  has to be programmed via the I<sup>2</sup>C-bus interface. An effective scaling factor from 2048 to 32767 can be selected by means of the I<sup>2</sup>C-bus bits  $n_i$  ( $i = 0, \dots, 14$ ) according to  $SF_{eff} = \sum n_i \times 2^i$ .

By setting the I<sup>2</sup>C-bus bit  $T$ , a test signal representing the divided input signal can be monitored at the switching output SWC.

When the supply voltage is switched on, both the reference divider and the programmable divider are kept in RESET state until a complete scaling factor is written onto the chip. Changes in the setting of the programmable divider become active when the corresponding I<sup>2</sup>C bus transmission is completed. An internal synchronization procedure ensures that such changes do not become active while the charge pump is sourcing or sinking current at its output pin. This behavior allows a smooth tuning of the output frequency without restricting the controlled VCO's frequency spectrum.

## Phase Comparator and Charge Pump

The tristate phase detector causes the charge pump to source or to sink current at the output Pin PD depending on the phase relation of its input signals which are provided by the reference and the main divider respectively. Four different values of this current can be selected by means of the I<sup>2</sup>C-bus bits I50 and I100. By use of this option, changes of the loop characteristics due to the variation of the VCO gain-as a function of the tuning voltage can be reduced. The charge-pump current can be switched off using the I<sup>2</sup>C-bus bit TRI. A change in the setting of the charge pump current becomes active when the corresponding I<sup>2</sup>C-bus transmission is completed. As described for the setting of the scaling factor of the programmable divider, an internal synchronization procedure ensures that such changes do not become active while the charge pump is sourcing or sinking current at its output pin. This behavior allows a change in the charge pump current without restricting the controlled VCO's frequency spectrum.

A high-gain amplifier (output pin: VD), which is implemented in order to construct a loop filter as shown in the application circuit, can be switched off by means of the I<sup>2</sup>C bus-bit OS.

An internal lock detector checks if the phase difference of the input signals of the phase detector is smaller than approximately 250 ns in seven subsequent comparisons. If phase lock is detected, the open collector output Pin PLCK is set H (logical value!). It should be noted that the output current of this pin must be limited by external circuitry as it is not limited internally. If the I<sup>2</sup>C-bus bit TRI is set H, the lock detector function is deactivated and the logical value of the PLCK output is undefined.

## Switching Outputs

Three switching outputs controlled by the I<sup>2</sup>C-bus bits SWA, SWB, SWC can be used for any switching task on the front end board. The currents of these outputs are not limited internally. They have to be limited by external circuit.

## D/A Converters

Three D/A converters, A, B and C, offer the possibility of generating three output voltages at a resolution of 8 bits. These voltages appear at the output Pins CAO, CBO and CCO. The converters are controlled via the I<sup>2</sup>C-bus interface by means of the control bits CA0, ..., CA7, CB0, ..., CB7 and CC0, ..., CC7 respectively as described in the section 'I<sup>2</sup>C-Bus Instruction Codes'. The output voltages are defined as

$$V_{CAO} = V_M / 128 \times \sum_{j=0, \dots, 7} CA_j \times 2^j,$$

$$V_{CBO} = V_M / 128 \times \sum_{j=0, \dots, 7} CB_j \times 2^j,$$

$$V_{CCO} = V_M / 128 \times \sum_{j=0, \dots, 7} CC_j \times 2^j,$$

where  $V_M = 4.25$  V nominally. Due to the rail-to-rail outputs of these converters, almost the full voltage range from 0 to 8.5 V can be used. A common application of these converters is the digital synthesis of control signals for the tuning of preselectors.

## I<sup>2</sup>C-Bus Interface

Via its I<sup>2</sup>C-bus interface, various functions can be controlled by a microprocessor. These functions are outlined in the following sections 'I<sup>2</sup>C-bus Instruction Codes' and 'I<sup>2</sup>C-bus Functions'. The programming information is stored in a set of internal registers. By means of the Pin ADR, four different I<sup>2</sup>C-bus addresses can be selected as described in the section 'Electrical characteristics'. In figure 4, the I<sup>2</sup>C-bus timing parameters are explained, figure 5 shows a typical I<sup>2</sup>C-bus pulse diagram.

## I<sup>2</sup>C-Bus Instruction Codes

Description	MSB							LSB
Address byte	1	1	0	0	0	AS1	AS2	0
A byte 1	0	0	X	X	X	n <sub>14</sub>	n <sub>13</sub>	n <sub>12</sub>
A byte 2	X	X	n <sub>11</sub>	n <sub>10</sub>	n <sub>9</sub>	n <sub>8</sub>	n <sub>7</sub>	n <sub>6</sub>
A byte 3	X	X	n <sub>5</sub>	n <sub>4</sub>	n <sub>3</sub>	n <sub>2</sub>	n <sub>1</sub>	n <sub>0</sub>
B byte 1	0	1	X	r <sub>8</sub>	TA3	TA2	TA1	TA0
B byte 2	r <sub>7</sub>	r <sub>6</sub>	r <sub>5</sub>	r <sub>4</sub>	TB3	TB2	TB1	TB0
B byte 3	r <sub>3</sub>	r <sub>2</sub>	r <sub>1</sub>	r <sub>0</sub>	TC3	TC2	TC1	TC0
C byte 1	1	0	X	X	X	X	X	X
C byte 2	CA7	CA6	CA5	CA4	CA3	CA2	CA1	CA0
C byte 3	CB7	CB6	CB5	CB4	CB3	CB2	CB1	CB0
D byte 1	1	1	0	OS	T	TRI	I100	I50
D byte 2	SWA	SWB	SWC	X	M3	M2	M1	M0
D byte 3	CC7	CC6	CC5	CC4	CC3	CC2	CC1	CC0

## I<sup>2</sup>C-Bus Functions

AS1, AS2 define the I<sup>2</sup>C-bus address

n<sub>i</sub> effective scaling factor (SF<sub>eff</sub>) of the main divider  
 $SF_{eff} = \sum n_i 2^i$

r<sub>i</sub> scaling factor (SF<sub>ref,eff</sub>) of the reference divider  
 $SF_{ref,eff} = 4 \times r_i 2^i$

TAi define the setting of a 4-bit D/A converter controlling the threshold, th1, of the RF AGC to adjust the controlled output power.

TBi define the setting of a 4-bit D/A converter controlling the threshold, th2, which determines the activation voltage for the internal RF AGC.

TCi define the setting of a 4-bit D/A converter controlling the threshold, th3, of the IF AGC to adjust the output power.

CAi, CBi, CCi define the setting of the three D/A converters A, B and C (i = 0, ..., 7)

OS OS = HIGH switches off the tuning output

T for T = HIGH, reference signals describing the output frequencies of the reference divider and programmable divider are monitored at SWA (reference divider) and SWC (programmable divider).

TRI TRI = HIGH switches off the charge pump

I50 and I100 define the charge pump current:

I50	I100	Charge-Pump Current (nominal) / μA
LOW	LOW	50
HIGH	LOW	102
LOW	HIGH	151
HIGH	HIGH	203

Mi defines the operation mode:

M3	M2	M1	M0	Mode
LOW	LOW	X	X	f <sub>LO,IFMIX</sub> = f <sub>ref</sub>
LOW	HIGH	X	X	f <sub>LO,IFMIX</sub> = 2 × f <sub>ref</sub>
HIGH	LOW	X	X	f <sub>LO,IFMIX</sub> = 2 × f <sub>ref</sub>
HIGH	HIGH	X	X	IF mixer switched off
X	X	LOW	LOW	RF mixer A active, f <sub>LO,RFMIX</sub> = f <sub>VCO</sub>
X	X	LOW	HIGH	RF mixer A active, f <sub>LO,RFMIX</sub> = f <sub>VCO</sub>
X	X	HIGH	LOW	RF mixer B active, f <sub>LO,RFMIX</sub> = f <sub>VCO</sub>
X	X	HIGH	HIGH	RF mixer B active, f <sub>LO,RFMIX</sub> = f <sub>VCO</sub> /2

SWα SWα = HIGH switches on the output current (α = A, B, C)



## I<sup>2</sup>C-Bus Data Transfer

### Format:

START – ADR – ACK – <instruction set> – STOP

The <instruction set> consists of a sequence of A bytes, B bytes, C bytes and D bytes each followed by ACK. Always a triplet of these bytes (A, B, C or D) has to be completed before a new triplet is started. If no new triplet is started the transmission can be finished before the current triplet is finished.

### Examples:

START – ADR – ACK – DB1 – ACK – DB2 – ACK – DB3 – ACK – CB1 – ACK – CB2 – ACK – CB3 – ACK – AB1 – ACK – AB2 – ACK – AB3 – ACK – BB1 – ACK – BB2 – ACK – BB3 – ACK – STOP

START – ADR – ACK – CB1 – ACK – CB2 – ACK – STOP

### However:

START – ADR – ACK – DB1 – ACK – CB1 – ACK – STOP is not allowed.

### Description:

START start condition  
STOP stop condition  
ACK acknowledge  
ADR address byte  
 $\alpha$ Bi  $\alpha$  byte i ( $\alpha = A, B, C, D; i=1,2,3$ )

## I<sup>2</sup>C-Bus Timing

The values of the periods shown are specified in the section 'Electrical Characteristics'. More detailed information can be taken from 'Application Note 1.0 (I<sup>2</sup>C-Bus Description)'. Please note: due to the I<sup>2</sup>C-bus specification, the MSB of a byte is transmitted first, the LSB last.

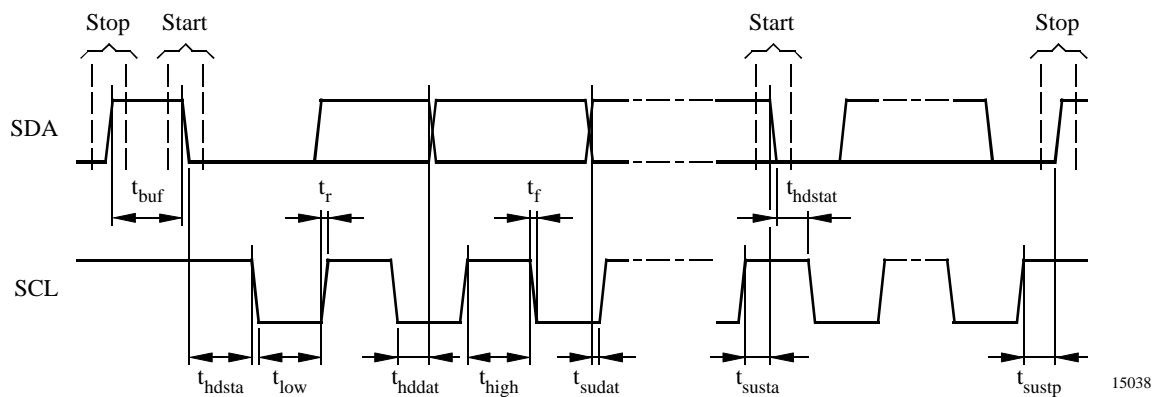

Figure 4. I<sup>2</sup>C-bus timing

## Typical Pulse Diagram

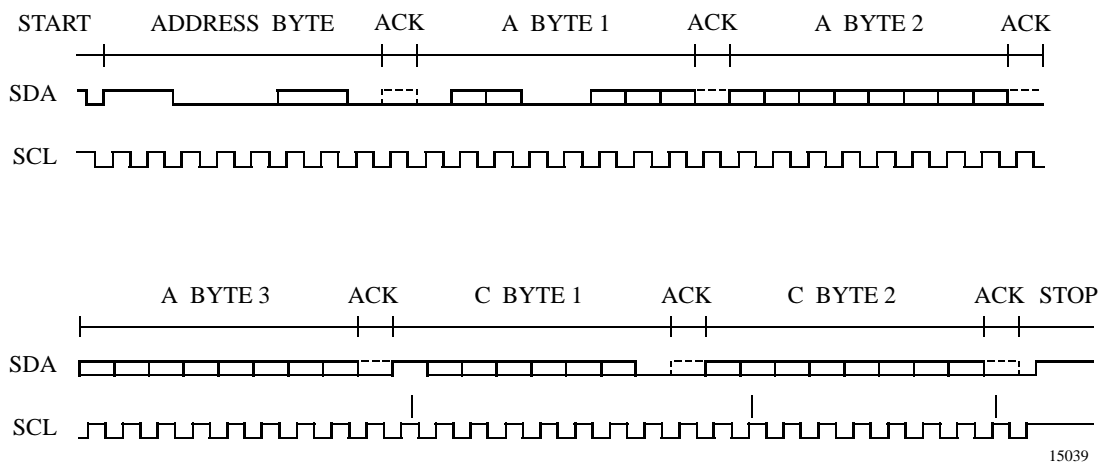

Figure 5. Typical pulse diagram

## Absolute Maximum Ratings

Parameters	Symbol	Min.	Typ.	Max.	Unit
Supply voltage	$V_S$	-0.3		+9.5	V
Junction temperature	$T_j$			150	°C
Storage temperature	$T_{stg}$	-40		+150	°C
Differential input RF amplifier	Pins 12 and 13 $V_{RFA1,2}$			500	mV <sub>rms</sub>
	Pins 14 and 15 $V_{RFB1,2}$			500	mV <sub>rms</sub>
Ext. applied voltage at RF charge pump output	Pin 16 $V_{CPRF}$	0.5		6.75	V
	Pin 28 $V_{CPIF}$	0.5		6.25	V
WAGC input voltage	Pin 22 $V_{WAGC}$	-0.3		5.5	V
SLI input voltage	Pin 21 $V_{SLI}$	-0.3		5.5	V
Differential base input VCO	Pins 33 and 34 $V_{BiVC}$			500	mV <sub>rms</sub>
Differential input IF amplifier	Pins 23 and 24 $V_{IFIN}$			500	mV <sub>rms</sub>
Differential input IF AGC block	Pins 26 and 27 $V_{IFAGCIN}$			500	mV <sub>rms</sub>
Reference input voltage (AC)	Pin 42 $V_{OSCI}$			1	V <sub>pp</sub>
I <sup>2</sup> C-bus input / output voltage	Pins 1 and 2 SCL, SDA	-0.3		5.5	V
SDA output current	Pin 2 SDA			5	mA
Address select voltage	Pin 44 ADR	-0.3		5.5	V
Switch output voltage	Pins 3, 4 and 6 $SW\alpha$	-0.3		9.5	V
Switch output current	$SW\alpha$	4			mA
PLCK output voltage	Pin 41 PLCK	-0.3		5.5	V
PLCK output current	Pin 41 PLCK			0.5	mA

## Operating Range

Parameters	Symbol	Value	Unit
Supply voltage	$V_S$	8.0 to 9.35	V
Ambient temperature range	$T_{amb}$	-40 to +85	°C

## Thermal Resistance

Parameters	Symbol	Value	Unit
Junction ambient SSO44 mod.	$R_{thJA}$	t.b.d.	K/W

## Electrical Characteristics

Test conditions (unless otherwise specified):  $V_S = 8.5\text{ V}$ ,  $T_{\text{amb}} = 25^\circ\text{C}$

Parameters	Test Conditions / Pins	Symbol	Min.	Typ.	Max.	Unit
<b>Overall characteristics</b>						
<b>Pins 20, 25 and 38</b>						
Supply voltage		$V_S$	8.0	8.5	9.35	V
Minimum supply current	$V(\text{CPRF}) = V(\text{CPIF}) < 0.8\text{ V}$ ; M3 = M2 = HIGH; M1 = M0 = LOW; TAi = TCi = '0000'; TBi = '1000'; SWA = SWB = SWC = LOW; TRI = LOW; PLCK = LOW; I100 = I50 = LOW; V(ADR) = open; SLI = LOW; WAGC = HIGH	$I_{S,\text{min}}$		74		mA
Maximum supply current	$3.4\text{ V} < V(\text{CPRF}) = V(\text{CPIF}) < 3.6\text{ V}$ ; M3 = M2 = HIGH; M1 = M0 = LOW; TAi = TCi = '0000'; TBi = '1000'; SWA = LOW; SWB = LOW; SWC = LOW; TRI = LOW; PLCK = LOW; I100 = I50 = LOW; V(ADR) = open; SLI = LOW; WAGC = HIGH	$I_{S,\text{max}}$		79		mA
<b>RF part</b>						
Voltage gain	RFA1, RFA2; (RFB1, RFB2) → SAW1, SAW2, (see figure 9) Pins 12 (14) → 18, 19	$G_{V,\text{RF}}$		26		dB
AGC range RF				27		dB
Noise figure (double side band)	RFA1, (RFB1) → SAW1, SAW2; RFA2, RFB2 blocked Pins 12 (14) → 19	$N_{\text{FDSB,RF}}$		12		dB
Maximum input power level	Differential, 3rd order intermodu- lation distance $\geq 40\text{ dBc}$ , Pout = -19 dBm, TAi = '0000', RL (SAW1, SAW2) = 200 $\Omega$ Pins 12 and 13 (14 and 15)	$P_{\text{in,max,MIX}}$		-10		dBm
Input frequency range	Pins 12 and 13 (14 and 15)	$f_{\text{in,RF}}$	70		260	MHz
Input impedance	Single ended, Pin 12 (14)	$Z_{\text{in,RF}}$		1.3		k $\Omega$
Output frequency range for AGC-voltage generation	Pin 18 and 19	$f_{\text{out,SAW}}$		38,912 $\pm 5$		MHz
Maximum output power level	Output power, differential; RL (SAW1, SAW2) > 200 $\Omega$ , TAi = '0000' Pins 18 and 19			-7		dBm
AGC threshold (th1) upper limit (TAi = '1111') lower limit (TAi = '0000')	Output power, differential controlled by I <sup>2</sup> C-bus bits TAi; RL (SAW1, SAW2) = 200 $\Omega$	$P_{\text{TH,RF}}$		-8 -22		dBm dBm

## Electrical Characteristics (continued)

Test conditions (unless otherwise specified):  $V_S = 8.5\text{ V}$ ,  $T_{\text{amb}} = 25^\circ\text{C}$

Parameters	Test Conditions / Pins	Symbol	Min.	Typ.	Max.	Unit
AGC threshold (th2) (internal AGC) upper limit (T <sub>Bi</sub> = '1111') lower limit (T <sub>Bi</sub> = '0000')	Controlled by I <sup>2</sup> C-bus bits T <sub>Bi</sub> ; P <sub>IN,MAX</sub> = -25 dBm Pin 16	$V_{\text{int AGC,RF}}$		5.1		V
				1.6		V
Output impedance	Single ended; f(SAW1) = 39 MHz, Pin 18 (19)	$Z_{\text{out,SAW}}$		30		$\Omega$
<b>VCO</b>						
Phase noise	$\Delta f = 10\text{ kHz}$	$L(f)$		-88		dBc/Hz
		$f_{\text{LO}}$	100		400	MHz
<b>IF part</b>						
Voltage gain	IFIN2 blocked, (see figure 9) $f_{\text{LO,IFMIX}} = f_{\text{ref}}$ or $f_{\text{LO,IFMIX}} = 2 \times f_{\text{ref}}$ Pin 24 → 29	$G_{V,\text{tot}}$	42	44	46	dB
Voltage gain	IFIN2 blocked, (see figure 9) IF mixer switched off Pin 24 → 29	$G_{V,\text{tot}}$	45	47	49	dB
AGC range IF				44		dB
Noise figure (double side band)	IFIN2 blocked, Pin 24 → 29	$\text{NF}_{\text{DSB}}$		11		dB
Maximum input power level	IFIN2 blocked, 3rd order inter-modulation distance $\geq 40\text{ dBc}$ ; RL(IFOUT) = 1 k; TCi = '0000'; R <sub>10</sub> = 4.7 k, R <sub>11</sub> = 1.8 k Pin 24	$P_{\text{in,max}}$		-20		dBm
Input frequency range	Pins 23 and 24	$f_{\text{in,IFIN}}$	10		60	MHz
Input impedance	IFIN2 blocked, $f_{\text{IF,IFIN}} = 38.912\text{ MHz}$ Pins 23 and 24	$Z_{\text{in,IFIN}}$		600 – j1000		$\Omega$
Output frequency range	Single ended Pin 28	$f_{\text{out,IFO}}$	1		45	MHz
Output impedance	Single ended Pin 28	$Z_{\text{out,IFOUT}}$		20+j50		$\Omega$
				65+j35		$\Omega$
				58-j25		$\Omega$
<b>RF AGC unit Pin 16</b>						
Positive charge pump current, fast mode	$V_{\text{WAGC}} = \text{LOW}$ , $V_{\text{SLI}} = \text{HIGH}$	$\text{ICPRF}_{\text{POS, FM}}$	145	180	220	$\mu\text{A}$
Negative charge pump current, fast mode	$V_{\text{WAGC}} = \text{LOW}$ , $V_{\text{SLI}} = \text{HOGH}$	$\text{ICPRF}_{\text{NEG, FM}}$	-220	-180	-145	$\mu\text{A}$
Positive charge pump current, slow mode	$V_{\text{WAGC}} = \text{LOW}$ , $V_{\text{SLI}} = \text{LOW}$	$\text{ICPRF}_{\text{POS, SM}}$	38	40	52	$\mu\text{A}$
Negative charge pump current, slow mode	$V_{\text{WAGC}} = \text{LOW}$ , $V_{\text{SLI}} = \text{LOW}$	$\text{ICPRF}_{\text{NEG, SM}}$	-52	-40	-38	$\mu\text{A}$

## Electrical Characteristics (continued)

Test conditions (unless otherwise specified):  $V_S = 8.5\text{ V}$ ,  $T_{\text{amb}} = 25^\circ\text{C}$

Parameters	Test Conditions / Pins	Symbol	Min.	Typ.	Max.	Unit
Window AGC mode charge pump current	$V_{\text{WAGC}} = \text{HIGH}$	$\text{ICPRF}_{\text{hi}}$	-500	0	+500	nA
Minimum gain control voltage		$\text{VAGC}_{\text{min}}$		0.75		V
Maximum gain control voltage		$\text{VAGC}_{\text{max}}$		6.6		V
<b>IF AGC unit</b>						
Positive charge pump current, fast mode	$V_{\text{WAGC}} = \text{LOW}$ , $V_{\text{SLI}} = \text{HIGH}$ Pin 28	$\text{ICPIF}_{\text{POS, FM}}$	145	180	220	$\mu\text{A}$
Negative charge pump current, fast mode	$V_{\text{WAGC}} = \text{LOW}$ , $V_{\text{SLI}} = \text{HIGH}$ Pin 28	$\text{ICPIF}_{\text{NEG, FM}}$	-220	-180	-145	$\mu\text{A}$
Positive charge pump current, slow mode	$V_{\text{WAGC}} = \text{LOW}$ , $V_{\text{SLI}} = \text{LOW}$ Pin 28	$\text{ICPIF}_{\text{POS, SM}}$	38	40	52	$\mu\text{A}$
Negative charge pump current, slow mode	$V_{\text{WAGC}} = \text{LOW}$ , $V_{\text{SLI}} = \text{LOW}$ Pin 28	$\text{ICPIF}_{\text{NEG, SM}}$	-52	-40	-38	$\mu\text{A}$
Window AGC mode charge pump current	$V_{\text{WAGC}} = \text{HIGH}$ Pin 28	$\text{ICPIF}_{\text{WAGC}}$	-4	0	+4	$\mu\text{A}$
Min. gain control voltage	Pin 28	$\text{VAGCIF}_{\text{min}}$		0.75		V
Max. gain control voltage	Pin 28	$\text{VAGCIF}_{\text{max}}$		5.9		V
Control voltage for activated WAGC	$\text{WAGC} = \text{HIGH}$ Pin 22	$\text{VWAGC}_{\text{High}}$	2.0			V
Control voltage for deactivated WAGC	$\text{WAGC} = \text{LOW}$ Pin 22	$\text{VWAGC}_{\text{Low}}$			0.7	V
Control voltage for activated SLI	$\text{SLI} = \text{HIGH}$ Pin 21	$\text{VSLI}_{\text{High}}$	2.0			V
Control voltage for deactivated SLI	$\text{SLI} = \text{LOW}$ Pin 21	$\text{VSLI}_{\text{Low}}$			0.7	V
<b>PLL part</b>						
Effective scaling factor of programmable divider		$\text{SF}_{\text{eff}}$	2048		32766	
Effective scaling factor of reference divider		$\text{SF}_{\text{ref,eff}}$	144		2047	
Tuning step				16		kHz
<b>REF input Pin 42</b>						
Input frequency range	Internal oscillator overdriven	$f_{\text{ref}}$	5		30	MHz
Input sensitivity	Internal oscillator overdriven	$V_{\text{ref,min}}$			50	mV <sub>rms</sub>
Maximum input signal	Internal oscillator overdriven	$V_{\text{ref,max}}$			300	mV <sub>rms</sub>
Input impedance	Single ended	$Z_{\text{ref}}$		$2 \parallel 2.5$		k $\Omega$ /pF

## Electrical Characteristics (continued)

Test conditions (unless otherwise specified):  $V_S = 8.5\text{ V}$ ,  $T_{\text{amb}} = 25^\circ\text{C}$

Parameters	Test Conditions / Pins	Symbol	Min.	Typ.	Max.	Unit
<b>REF output</b> <span style="float: right;"><b>Pin 5</b></span>						
Output voltage	2.7kΩ    2.5pF load	$V_{\text{out,ref}}$	70			mV <sub>rms</sub>
<b>Phase detector</b> <span style="float: right;"><b>Pin 39</b></span>						
Charge-pump current	I100 = HIGH, I50 = HIGH	$\pm I_{\text{PD4}}$	±160	±203	±240	μA
	I100 = HIGH, I50 = LOW	$\pm I_{\text{PD3}}$	±120	±151	±180	μA
	I100 = LOW, I50 = HIGH	$\pm I_{\text{PD2}}$	±80	±102	±120	μA
	I100 = LOW, I50 = LOW	$\pm I_{\text{PD1}}$	±40	±50	±60	μA
High impedance mode	TRI = HIGH	$\pm I_{\text{PD,tri}}$		±100		nA
Effective phase noise <sup>*)</sup>	$I_{\text{PD}} = 203\ \mu\text{A}$	$L_{\text{PD}}$		-159		dBc/Hz
<b>Lock indication</b> <span style="float: right;"><b>Pin 41</b></span>						
Leakage current	$V_{\text{PLCK}} = 5.5\text{ V}$	$I_{\text{PLCK,L}}$			10	μA
Saturation voltage	$I_{\text{PLCK}} = 0.25\text{ mA}$	$V_{\text{PLCK,sat}}$			0.5	V
<b>Switches</b> <span style="float: right;"><b>Pins 3, 4 and 6</b></span>						
Leakage current		$I_{\text{SW,L}}$			t.b.d.	μA
Saturation voltage	$I_{\text{SW}} = 0.25\text{ mA}$	$V_{\text{SW,sat}}$			0.5	V
<b>Address selection</b> <span style="float: right;"><b>Pin 44</b></span>						
AS1 = 0, AS2 = 0			0		0.1 $V_S$	
AS1 = 0, AS2 = 1				open		
AS1 = 1, AS2 = 0			0.4 $V_S$		0.6 $V_S$	
AS1 = 1, AS2 = 1			0.9 $V_S$		$V_S$	
<b>D/A converters</b> <span style="float: right;"><b>Pins 7, 8 and 9</b></span>						
Output voltage	$C\alpha 7 = \text{HIGH}$ , $C\alpha 0$ to $C\alpha 6 = \text{LOW}$ , $\alpha = \text{A, B, C}$	$V_M$		4.25		V
Variation of $V_M$	$V_S = 7.65$ to $9.35\text{ V}$	$\Delta V_{M,VS}$		±100		mV
	$T_{\text{amb}} = -40$ to $+85^\circ\text{C}$	$\Delta V_{M,temp}$		±50		mV
Dynamic range	$ VC\alpha 0 - n V_M/128  \leq 70\text{ mV}$ , $n = \sum C\alpha j \times 2^j$ , $\alpha = \text{A, B, C}$	$V_{\text{LL}}, V_{\text{UL}}$	0.5		8.0	V
Maximum output current		$I_{\text{CAOmax}}$ $I_{\text{CBOmax}}$ $I_{\text{CCOmax}}$		20		μA
<b>I<sup>2</sup>C bus</b> <span style="float: right;"><b>Pins 1 and 2</b></span>						
Input voltage SCL/SDA	HIGH		3		5.5	V

\*) The phase detector's phase-noise contribution to the VCO's frequency spectrum is determined by the operating frequency of the phase detector divided by 4 according to the fractional-N technique (regularly: 16 kHz).

## Electrical Characteristics (continued)

Test conditions (unless otherwise specified):  $V_S = 8.5\text{ V}$ ,  $T_{amb} = 25^\circ\text{C}$

Parameters	Test Conditions / Pins	Symbol	Min.	Typ.	Max.	Unit
Input voltage SCL/SDA	LOW				1.5	V
Output voltage SDA (open collector)	$I_{SDA} = 2\text{ mA}$ , SDA = LOW				0.4	V
SCL clock frequency			0.1		100	kHz
Rise time (SCL, SDA)		$t_r$			1	$\mu\text{s}$
Fall time (SCL; SDA)		$t_f$			300	ns
Time before new transmission can start		$t_{buf}$	4.7			$\mu\text{s}$
SCL HIGH period		$t_{high}$	4			$\mu\text{s}$
SCL LOW period		$t_{low}$	4.7			$\mu\text{s}$
Hold time START		$t_{hdsta}$	4			$\mu\text{s}$
Setup time START		$t_{susta}$	4.7			$\mu\text{s}$
Setup time STOP		$t_{sustp}$	4.7			$\mu\text{s}$
hold time DATA		$t_{hddat}$	0			$\mu\text{s}$
Setup time DATA		$t_{sudat}$	250			ns

## Application Circuit

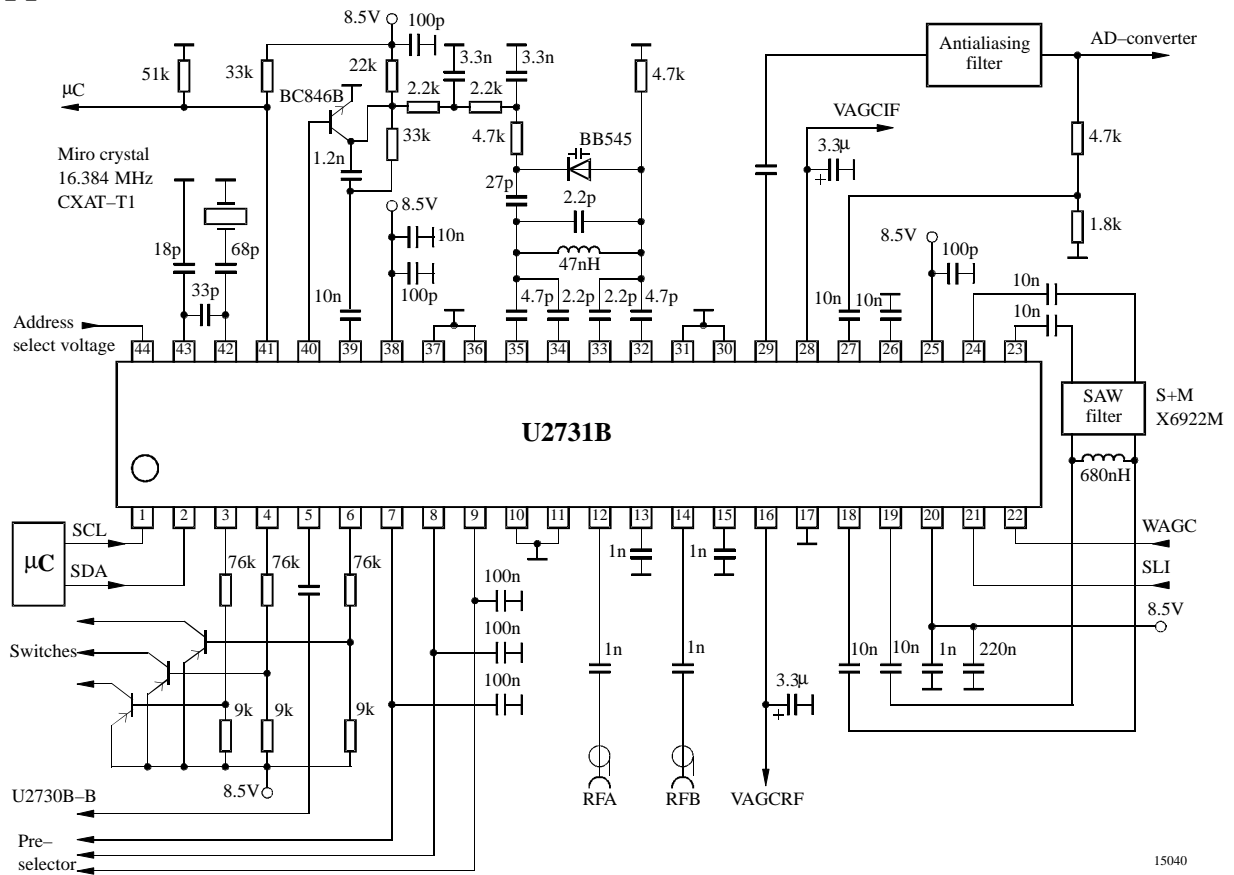

Figure 6. Application circuit

## Application Circuits of the Reference Oscillator

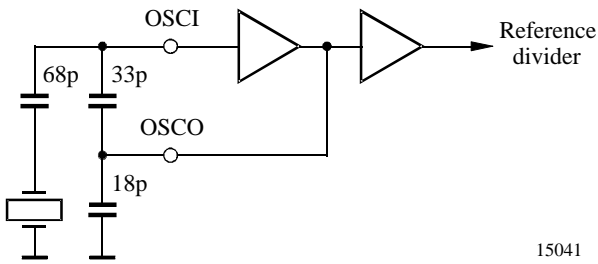

Figure 7. Oscillator operation

15041

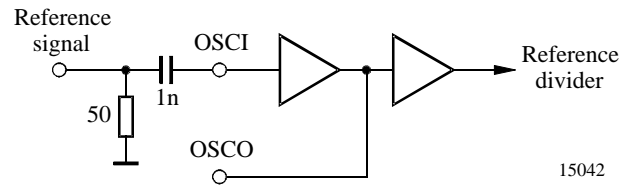

Figure 8. Oscillator overdriven

15042

## Measurement Circuit for Electrical Characteristics

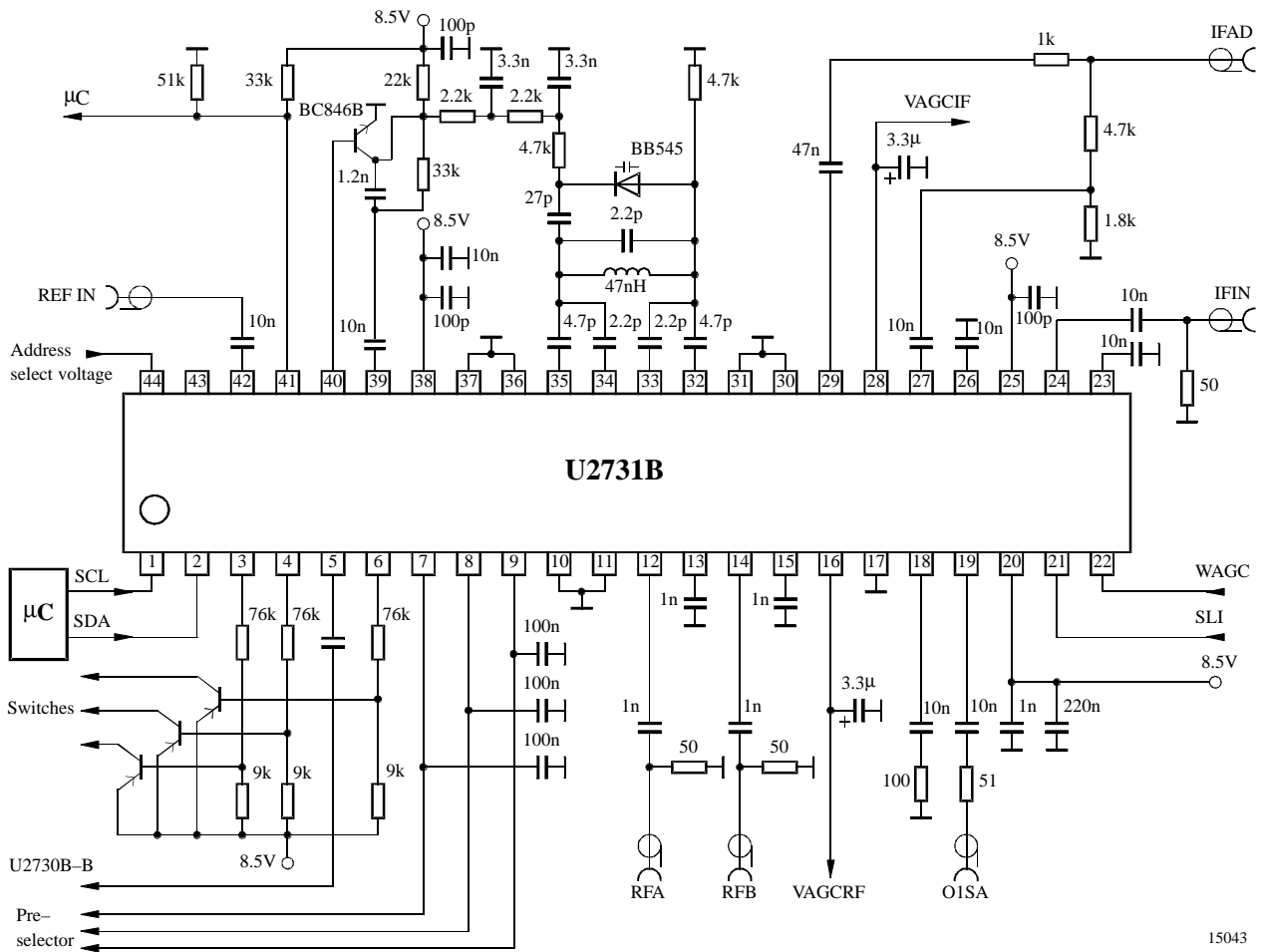

Figure 9. Measurement circuit for electrical characteristics

15043



**RFAGC Voltage-Generation Block Circuit**

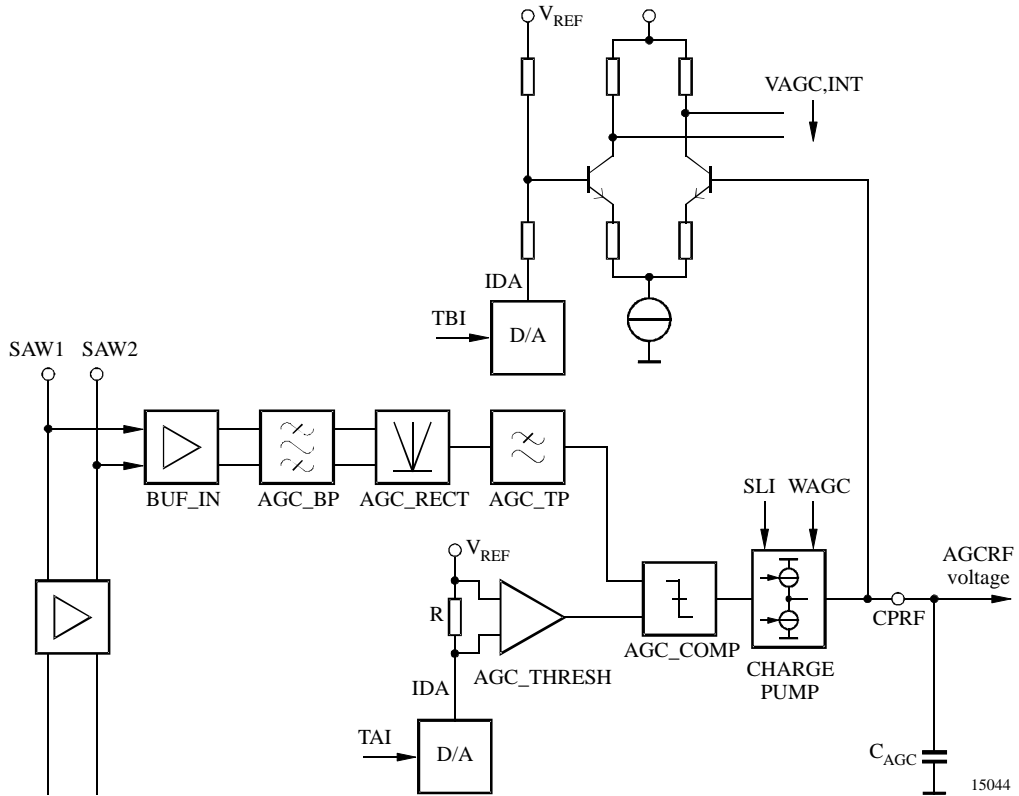

Figure 10. RFAGC voltage-generation block circuit

**IFAGC Voltage-Generation Block Circuit**

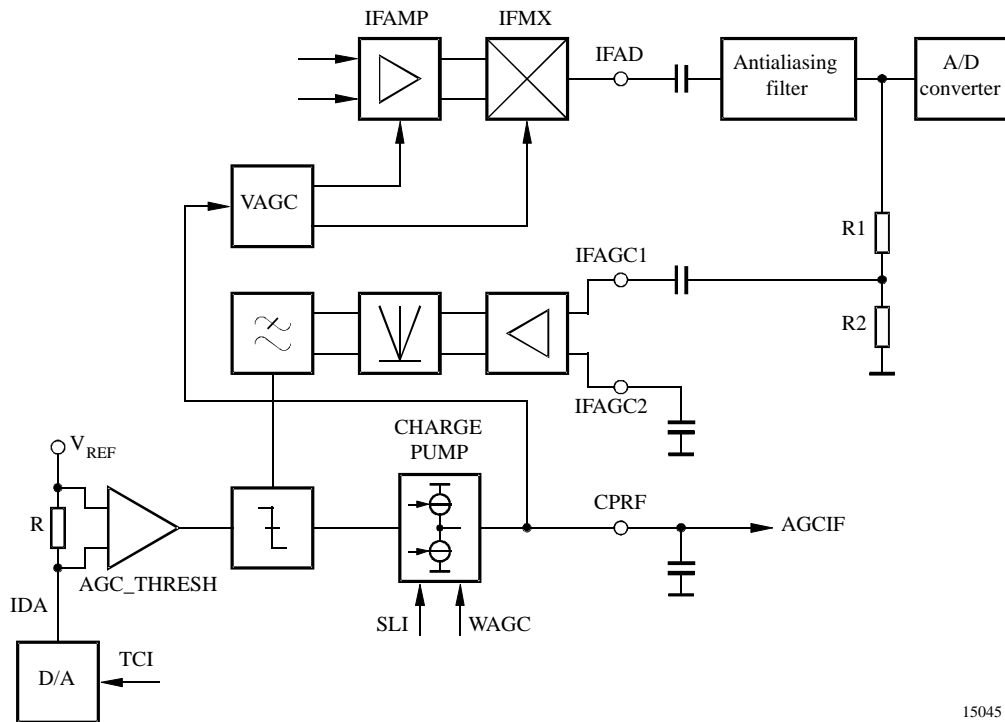

Figure 11. IFAGC voltage-generation block circuit

## VCO Circuit

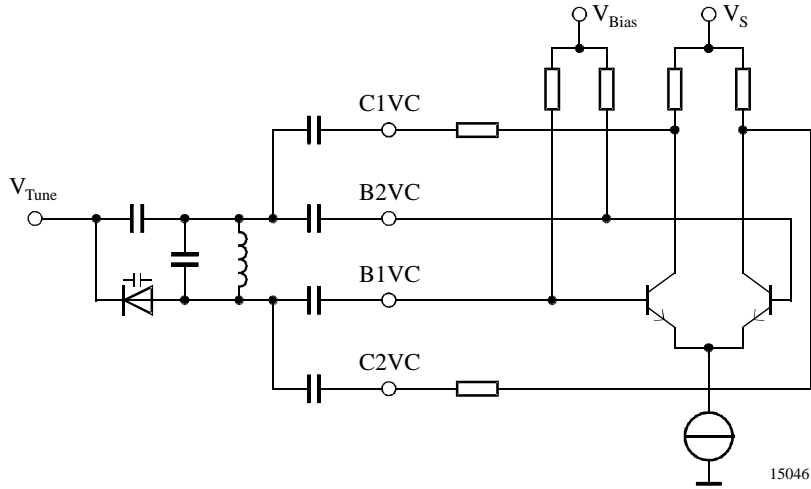

Figure 12. VCO circuit

## Phase-Noise Performance

(Example:  $SF_{\text{eff}} = 16899$ ,  $SF_{\text{ref,eff}} = 1120$ ,  $f_{\text{ref}} = 17.92$  MHz,  $I_{\text{PD}} = 200$   $\mu$ A, spectrum analysis: HP7000)

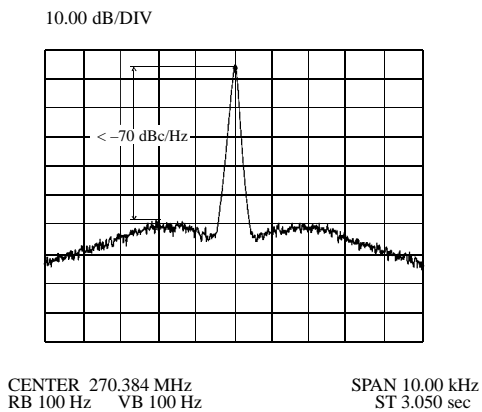

Figure 13.

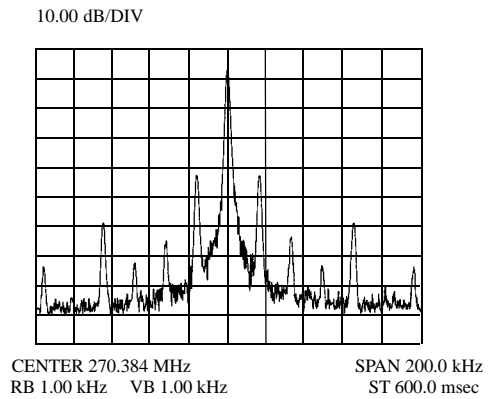
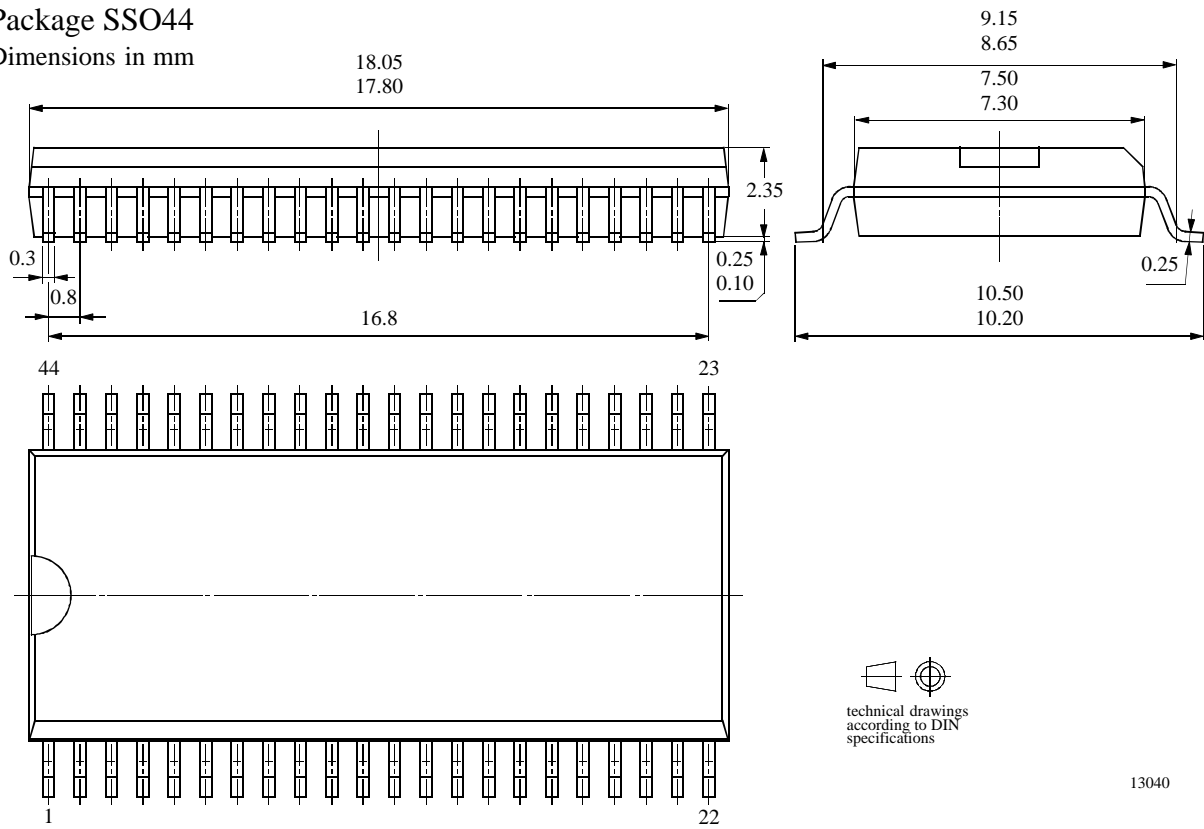

Figure 14.

**Package Information**

Package SSO44

Dimensions in mm



## Ozone Depleting Substances Policy Statement

It is the policy of **Atmel Germany GmbH** to

1. Meet all present and future national and international statutory requirements.
2. Regularly and continuously improve the performance of our products, processes, distribution and operating systems with respect to their impact on the health and safety of our employees and the public, as well as their impact on the environment.

It is particular concern to control or eliminate releases of those substances into the atmosphere which are known as ozone depleting substances (ODSs).

The Montreal Protocol (1987) and its London Amendments (1990) intend to severely restrict the use of ODSs and forbid their use within the next ten years. Various national and international initiatives are pressing for an earlier ban on these substances.

**Atmel Germany GmbH** has been able to use its policy of continuous improvements to eliminate the use of ODSs listed in the following documents.

1. Annex A, B and list of transitional substances of the Montreal Protocol and the London Amendments respectively
2. Class I and II ozone depleting substances in the Clean Air Act Amendments of 1990 by the Environmental Protection Agency (EPA) in the USA
3. Council Decision 88/540/EEC and 91/690/EEC Annex A, B and C (transitional substances) respectively.

**Atmel Germany GmbH** can certify that our semiconductors are not manufactured with ozone depleting substances and do not contain such substances.

**We reserve the right to make changes to improve technical design and may do so without further notice.**

Parameters can vary in different applications. All operating parameters must be validated for each customer application by the customer. Should the buyer use Atmel Wireless & Microcontrollers products for any unintended or unauthorized application, the buyer shall indemnify Atmel Wireless & Microcontrollers against all claims, costs, damages, and expenses, arising out of, directly or indirectly, any claim of personal damage, injury or death associated with such unintended or unauthorized use.

**Data sheets can also be retrieved from the Internet: <http://www.atmel-wm.com>**

Atmel Germany GmbH, P.O.B. 3535, D-74025 Heilbronn, Germany  
Telephone: 49 (0)7131 67 2594, Fax number: 49 (0)7131 67 2423