

- **2.7-V Operation**
- **Two Differential Microphone Inputs, One Differential Earphone Output, and One Single-Ended Earphone Output**
- **Programmable Gain Amplifiers for Transmit, Receive, Sidetone, and Volume Control**
- **Earphone Mute and Microphone Mute**
- **On-Chip I²C Bus, Which Provides a Simple, Standard, Two-Wire Serial Interface With Digital ICs**
- **Programmable for 15-Bit Linear Data or 8-Bit Companded (μ-Law or A-Law) Data**
- **Available in a 32-Pin Thin Quad Flatpack (TQFP) Package and an 80-Pin GQE MicroStar Junior™ Ball Grid Array (BGA)**
- **Designed for Analog and Digital Wireless Handsets and Telecommunications Applications**
- **Dual-Tone Multifrequency (DTMF) and Single Tone Generator**
- **Pulse Density Modulated (PDM) Buzzer Output**

description

The voice-band audio processor (VBAP) is designed to perform transmit encoding analog/digital (A/D) conversion, receive decoding digital/analog (D/A) conversion, and transmit and receive filtering for voice-band communications systems. The device operates in either the 15-bit linear or 8-bit companded (μ-law or A-Law) mode, which is selectable through the I²C interface. The VBAP generates its own internal clocks from a 2.048-MHz master clock input.

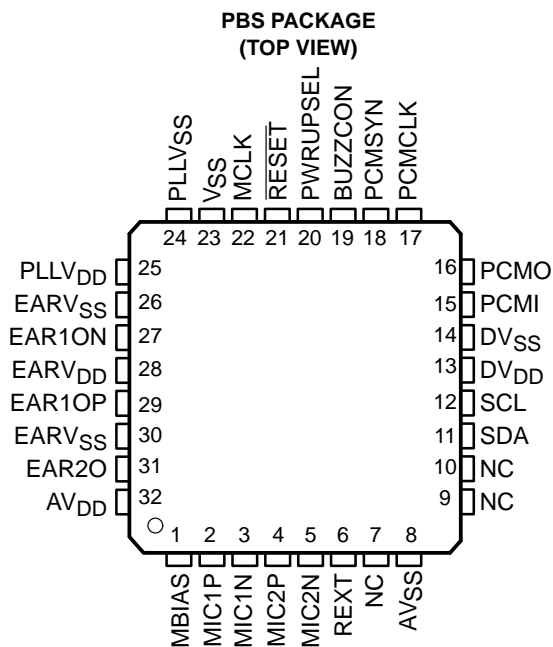

NC – No internal connection



This device contains circuits to protect its inputs and outputs against damage due to high static voltages or electrostatic fields. These circuits have been qualified to protect this device against electrostatic discharges (ESD) of up to 2 kV according to MIL-STD-883C, Method 3015; however, it is advised that precautions be taken to avoid application of any voltage higher than maximum-rated voltages to these high-impedance circuits. During storage or handling, the device leads should be shorted together or the device should be placed in conductive foam. In a circuit, unused inputs should always be connected to an appropriated logic voltage level, preferably either V_{CC} or ground. Specific guidelines for handling devices of this type are contained in the publication *Guidelines for Handling Electrostatic-Discharge-Sensitive (ESDS) Devices and Assemblies* available from Texas Instruments.

MicroStar Junior and VBAP are trademarks of Texas Instruments.
 All other trademarks are the property of their respective owners.

PRODUCTION DATA information is current as of publication date. Products conform to specifications per the terms of Texas Instruments standard warranty. Production processing does not necessarily include testing of all parameters.



TWL1103 VOICE-BAND AUDIO PROCESSOR (VBAP™)

SLWS108A – JULY 2000 – JANUARY 2001

functional block diagram

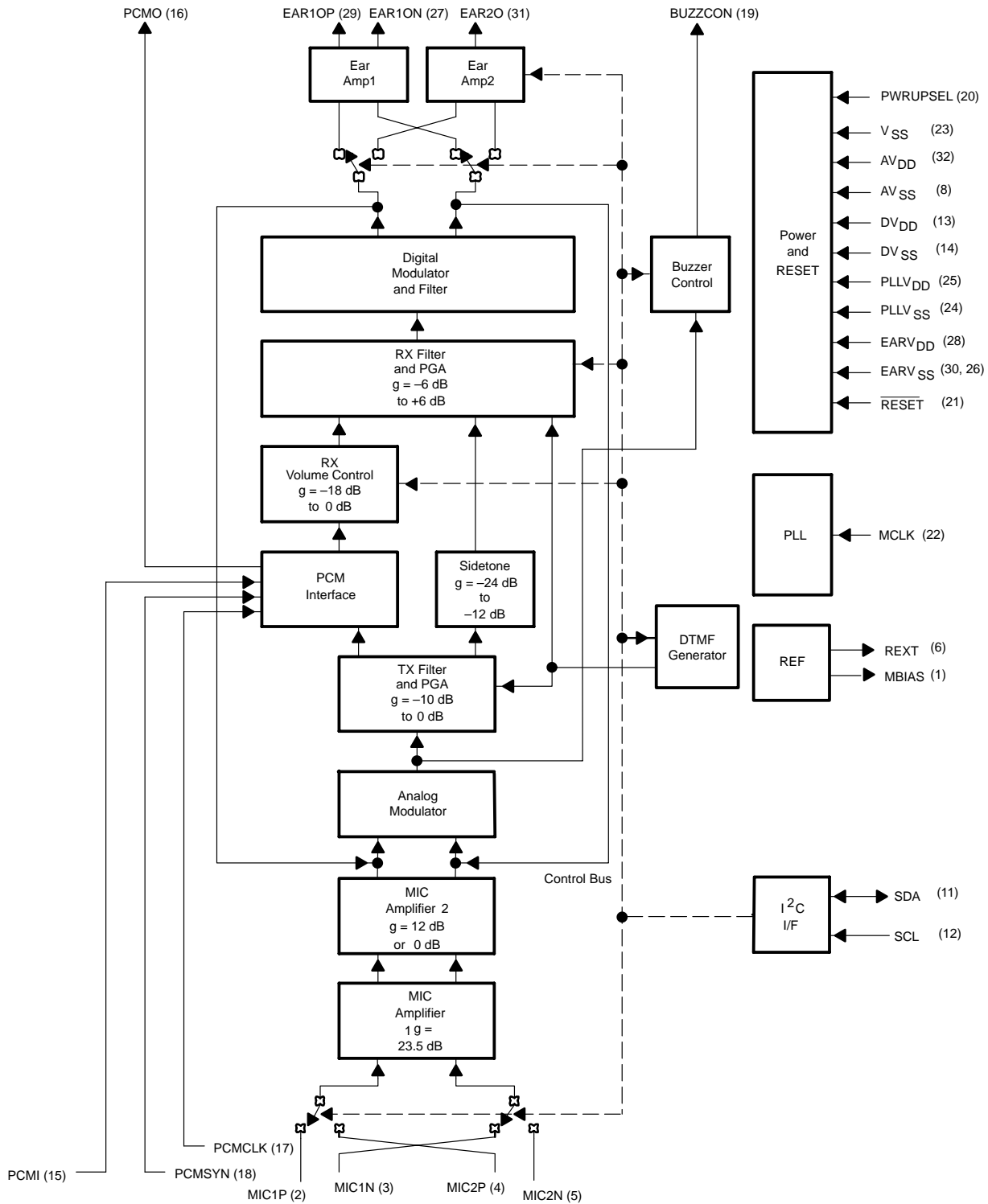

functional description

power on/reset

The power for the various digital and analog circuits is separated to improve the noise performance of the device. An external reset must be applied to the active low $\overline{\text{RESET}}$ terminal to guarantee reset upon power on. After the initial power-on sequence the TWL1103 can be functionally powered up and down by writing to the power control register through the I²C interface. There is a hardwired selectable power-up terminal in default mode option. The PWRUPSEL function allows the VBAP to power up in the default mode and allows use without a microcontroller.

reference

A precision band gap reference voltage is generated internally and supplies all required voltage references to operate the transmit and receive channels. The reference system also supplies bias voltage for use with an electret microphone at terminal MBIAS. An external precision resistor is required for reference current setting at terminal REXT.

control interface

The I²C interface is a two-wire bidirectional serial interface that controls the VBAP by writing data to the six control registers:

- Power control
- Mode control
- Transmit PGA and sidetone control
- Receive PGA gain and volume control
- DTMF high tone
- DTMF low tone

There are two power-up modes which may be selected at the PWRUPSEL terminal:

- The PWRUPSEL state (V_{DD} at terminal 20) causes the device to power up in the default mode when power is applied. In the default mode, the I²C interface is not required, and the device may be used without an I²C interface. The programmable functions are fixed in the default modes.
- The PWRUPSEL state (ground at terminal 20) causes the device to go to a power-down state when power is applied. In this mode an I²C interface is required to power up the device.

phase-locked loop

The internal digital filters and modulators require a 10.24-MHz clock that is generated by phase locking to the 2.048-MHz master clock input.

PCM interface

The PCM interface transmits and receives data at the PCMO and PCMI terminals respectively. The data is transmitted or received at the PCMCLK speed once every PCMSYN cycle. The PCMCLK can be tied directly to the 2.048-MHz master clock (MCLK). The PCMSYN can be driven by an external source or derived from the master clock and used as an interrupt to the host controller.

microphone amplifiers

The microphone input is a switchable interface for two differential microphone inputs. The first stage is a low-noise differential amplifier that provides a gain of 23.5 dB. The second stage amplifier has a selectable gain of 0 dB or 12 dB.

TWL1103

VOICE-BAND AUDIO PROCESSOR (VBAP™)

SLWS108A – JULY 2000 – JANUARY 2001

functional description (continued)

analog modulator

The transmit channel modulator is a third-order sigma-delta design.

transmit filter and PGA

The transmit filter is a digital filter designed to meet CCITT G.714 requirements. The device operates in either the 15-bit linear or 8-bit companded μ -law or A-law mode that is selectable through the I²C interface. The transmit PGA defaults to 0 dB.

sidetone

A portion of the transmitted audio is attenuated and fed back to the receive channel through the sidetone path. The sidetone path defaults to –12 dB. The sidetone path can be enabled by writing to the power control register.

receive volume control

The receive volume control block acts as an attenuator with a range of –18 dB to 0 dB in 2 dB steps for control of the receive channel volume. The receive volume control gain defaults to 0 dB.

receive filter and PGA

The receive filter is a digital filter that meets CCITT G.714 requirements with a high-pass filter that is selectable through the I²C interface. The device operates in either the 15-bit linear or 8-bit μ -law or A-law companded mode, which is selectable through the I²C interface. The gain defaults to –1 dB representing a 3-dBm₀ level for a 32- Ω load impedance and the corresponding digital full scale PCMI code. The gain may be set to –2 dB for the respective 3-dBm₀ level for a 16- Ω load impedance.

digital modulator and filter

The second-order digital modulator and filter convert the received digital PCM data to the analog output required by the earphone interface.

earphone amplifiers

The analog signal can be routed to either of two earphone amplifiers, one with differential output (EAR1ON and EAR1OP) and one with single-ended output (EAR2O). Clicks and pops are suppressed for EAR1 differential output only.

tone generator

The tone generator provides generation of standard DTMF tones and single tone frequencies which are output to the following devices: 1) The buzzer driver, as a pulse density modulation (PDM) signal 2) The receive path digital/analog converter (DAC) for outputting through the earphone. There are 255 possible single tones. The tone integer value is determined by the following formula:

$$\text{Round}(\text{Tone Freq (Hz)}/7.8135 \text{ Hz})$$

The value is loaded into one of two 8-bit registers, the high-tone register (04), or the low-tone register (05). The tone output is 2 dB higher when applied to the high-tone register (04). When generating DTMF tones, the high DTMF tone must be applied to the high-tone register and the low frequency tone to the low-tone register.



POST OFFICE BOX 655303 • DALLAS, TEXAS 75265

Terminal Functions

| TERMINAL | | | I/O | DESCRIPTION |
|----------|--------|--------|-----|---|
| NAME | NO. | | | |
| | μBGA | PBS | | |
| AVDD | A1 | 32 | I | Analog positive power supply |
| AVSS | J1 | 8 | I | Analog negative power supply |
| BUZZCON | F9 | 19 | O | Buzzer output, a pulse-density modulated signal to apply to external buzzer driver |
| DVDD | J6 | 13 | I | Digital positive power supply |
| DVSS | J7 | 14 | I | Digital negative power supply |
| EAR1ON | A6 | 27 | O | Earphone 1 amplifier output (–) |
| EAR1OP | A4 | 29 | O | Earphone 1 amplifier output (+) |
| EAR2O | A2 | 31 | O | Earphone 2 amplifier output |
| EARVDD | A5 | 28 | I | Analog positive power supply for the earphone amplifiers |
| EARVSS | A3, A7 | 30, 26 | I | Analog negative power supply for the earphone amplifiers |
| MBIAS | B1 | 1 | O | Microphone bias supply output, no decoupling capacitors |
| MCLK | C9 | 22 | I | Master system clock input (2.048 MHz) (digital) |
| MIC1P | C1 | 2 | I | MIC1 input (+) |
| MIC1N | D1 | 3 | I | MIC1 input (–) |
| MIC2P | E1 | 4 | I | MIC2 input (+) |
| MIC2N | F1 | 5 | I | MIC2 input (–) |
| PCMI | J8 | 15 | I | Receive PCM input |
| PCMO | J9 | 16 | O | Transmit PCM output |
| PCMSYN | G9 | 18 | I | PCM frame synchronization |
| PCMCLK | H9 | 17 | I | PCM data clock |
| PLLVSS | A9 | 24 | I | PLL negative power supply |
| PLLVDD | A8 | 25 | I | PLL digital power supply |
| PWRUPSEL | E9 | 20 | I | Selects the power-up default mode |
| REXT | G1 | 6 | I/O | Internal reference current setting terminal—use precision 100-kΩ resistor and no filtering capacitors |
| RESET | D9 | 21 | I | Active low reset |
| SCL | J5 | 12 | I | I ² C-bus serial clock—this input is used to synchronize the data transfer from and to the VBAP |
| SDA | J4 | 11 | I/O | I ² C-bus serial address/data input/output—this is a bidirectional terminal used to transfer register control addresses and data into and out of the CODEC. It is an open-drain terminal and therefore requires a pullup resistor to V _{DD} (typical 10 kΩ for 100 kHz) |
| VSS | B9 | 23 | I | Ground return for bandgap internal reference |

TWL1103 VOICE-BAND AUDIO PROCESSOR (VBAP™)

SLWS108A – JULY 2000 – JANUARY 2001

absolute maximum ratings over operating free-air temperature range (unless otherwise noted)†

| | |
|--|------------------------------|
| Supply voltage range, V_{DD} , DV_{DD} , PLL_{VDD} , EAR_{VDD} | -0.5 V to 4 V |
| Output voltage range, V_O | -0.5 V to 4 V |
| Input voltage range, V_F | -0.5 V to 4 V |
| Continuous total power dissipation | See Dissipation Rating Table |
| Operating free air temperature range, T_A (industrial temperature) | -40°C to 85°C |
| Storage temperature range, testing, T_{stg} | -65°C to 150°C |
| Lead temperature 1,6 mm from case for 10 seconds | 260°C |

† Stresses beyond those listed under “absolute maximum ratings” may cause permanent damage to the device. These are stress ratings only, and functional operation of the device at these or any other conditions beyond those indicated under “recommended operating conditions” is not implied. Exposure to absolute-maximum-rated conditions for extended periods may affect device reliability.

DISSIPATION RATING TABLE

| PACKAGE | $T_A \leq 25^\circ\text{C}$ POWER RATING | DERATING FACTOR ABOVE $T_A = 25^\circ\text{C}$ | $T_A = 85^\circ\text{C}$ POWER RATING |
|---------|---|---|--|
| PBS | 680 mW | 6.8 mW/°C | 270 mW |

recommended operating conditions (see Notes 1 and 2)

| | MIN | NOM | MAX | UNIT |
|--|----------------|-----|-----|----------|
| Supply voltage, V_{DD} , DV_{DD} , PLL_{VDD} , EAR_{VDD} | 2.7 | | 3.3 | V |
| High-level input voltage (V_{IH}) | 0.7 x V_{DD} | | | V |
| Low-level input voltage (V_{IL}) | 0.3 x V_{DD} | | | V |
| Load impedance between EAR_{1OP} and EAR_{1ON-RL} | 16 | | 32 | Ω |
| Load impedance for EAR_{2OP-RL} | | 32 | | Ω |
| Operating free-air temperature, T_A | -40 | | 85 | °C |

NOTES: 1. To avoid possible damage and resulting reliability problems to these CMOS devices, the power-on initialization paragraph must be followed, described in the Principles of Operations.
2. Voltages are with respect to AV_{SS} , DV_{SS} , PLL_{VSS} , and EAR_{VSS} .



electrical characteristics, $V_{DD} = 2.7\text{ V}$, $T_A = 25^\circ\text{ C}$ (unless otherwise noted)

supply current

| PARAMETER | | TEST CONDITIONS | MIN | TYP | MAX | UNIT |
|-------------|-------------------------------|--|-----|-----|-----|---------------|
| I_{DD} | Supply current from V_{DD} | Operating, EAR1 selected, MicBias disabled | | 6 | 7 | mA |
| | | Operating, EAR2 selected, MicBias disabled | | 5.4 | 6 | mA |
| | | Power down, Reg 2 bit 7 = 1, MClk not present (see Note 3) | | 0.5 | 10 | μA |
| | | Power down, Reg 2 bit 7 = 0, MClk not present (see Note 3) | | 25 | 40 | μA |
| $t_{on(i)}$ | Power-up time from power down | | 5 | 10 | ms | |

NOTE 3: $V_{IH} = V_{DD}$, $V_{IL} = V_{SS}$

digital interface

| PARAMETER | | TEST CONDITIONS | MIN | TYP | MAX | UNIT |
|-----------|---|---|-----------|-----|-----|---------------|
| V_{OH} | High-level output voltage, PCMO and BuzzCon | $I_{OH} = -3.2\text{ mA}$, $V_{DD} = 3\text{ V}$ | DV_{DD} | | | V |
| V_{OL} | Low-level output voltage, PCMO and BuzzCon | $I_{OL} = 3.2\text{ mA}$, $V_{DD} = 3\text{ V}$ | | | 0 | V |
| I_{IH} | High-level input current, any digital input | $V_I = V_{DD}$ | | | 10 | μA |
| I_{IL} | Low-level input current, any digital input | $V_I = V_{SS}$ | | | 10 | μA |
| C_I | Input capacitance | | | | 10 | pF |
| C_O | Output capacitance | | | | 20 | pF |
| R_L | Load impedance (BuzzCon) | | | | 5 | k Ω |

microphone interface

| PARAMETER | | TEST CONDITIONS | MIN | TYP | MAX | UNIT |
|---------------|--|---|------|-----|------|---------------------|
| V_{IO} | Input offset voltage at MIC1N, MIC2N | See Note 4 | -5 | | 5 | mV |
| I_{IB} | Input bias current at MIC1N, MIC2N | | -200 | | 200 | nA |
| C_i | Input capacitance at MIC1N, MIC2N | | | 5 | | pF |
| V_n | Microphone input referred noise, psophometric weighted (C-message weighted is similar) | Micamp 1 gain = 23.5 dB Micamp 2 gain = 0 dB | | 3.0 | 7.7 | μV_{rms} |
| I_{Omax} | Output source current MBIAS | | 1 | | 1.2 | mA |
| $V_{(mbias)}$ | Microphone bias supply voltage (see Note 5) | | 2.4 | 2.5 | 2.55 | V |
| | MICMUTE | | -80 | | | dB |
| | Input impedance | Fully differential | 35 | 60 | 100 | k Ω |

NOTES: 4. Measured while MIC1P and MIC1N are connected together. Less than 5 mV offset results in 0 value code on PCMOUT.

5. Not a JEDEC symbol.

speaker interface

| PARAMETER | | TEST CONDITIONS | MIN | TYP | MAX | UNIT |
|---|---------------------------------------|---|-----|---------|----------|------|
| Earphone AMP1 output power (See Note 6) | | $V_{DD} = 2.7\text{ V}$, fully differential, 16- Ω load, 3-dBm0 output, RGXPA = -2 dB | | 120.9 | 151.1 | mW |
| | | $V_{DD} = 2.7\text{ V}$, fully differential, 32- Ω load, 3-dBm0 output, RGXPA = -1 dB | | 76.1 | 95.1 | mW |
| Earphone AMP2 output power (See Note 6) | | $V_{DD} = 2.7\text{ V}$, single ended, 32- Ω load, 3-dBm0 output | | 10 | 12.5 | mW |
| V_{OO} | Output offset voltage at EAR1 | Fully differential | | ± 5 | ± 30 | mV |
| I_{Omax} | Maximum output current for EAR1(rms) | 3-dBm0 input, 16- Ω load | | 86.9 | 108.6 | mA |
| | | 3-dBm0 input, 32- Ω load | | 48.7 | 60.8 | |
| | Maximum output current for EAR2 (rms) | 3-dBm0 input | | 17.7 | 22.1 | |
| EARMUTE | | | -80 | | | dB |

NOTE 6: Maximum power is with a load impedance of approximately 12 Ω .

TWL1103

VOICE-BAND AUDIO PROCESSOR (VBAP™)

SLWS108A – JULY 2000 – JANUARY 2001

electrical characteristics, $V_{DD} = 2.7\text{ V}$, $T_A = 25^\circ\text{ C}$ (unless otherwise noted) (continued)

transmit gain and dynamic range, companded mode (μ -law or A-law) or linear mode selected, transmit slope filter bypassed (see Notes 7 and 8)

| PARAMETER | TEST CONDITIONS | MIN | TYP | MAX | UNIT |
|---|--|------|-----|-----|------------------|
| Transmit reference-signal level (0 dB) | Differential | | | 175 | mV _{pp} |
| Overload-signal level (3 dBm0) | Differential, normal mode | | | 248 | mV _{pp} |
| | Differential, extended mode | | | 63 | mV _{pp} |
| Absolute gain error | 0 dBm0 input signal, $V_{DD} = 2.7\text{ V}$ (minimum) | -1 | | 1 | dB |
| Gain error with input level relative to gain at -10 dBm0 MIC1N, MIC1P to PCMO | MIC1N, MIC1P to PCMO at 3 dBm0 to -30 dBm0 | -0.5 | | 0.5 | dB |
| | MIC1N, MIC1P to PCMO at -31 dBm0 to -45 dBm0 | -1 | | 1 | |
| | MIC1N, MIC1P to PCMO at -46 dBm0 to -55 dBm0 | -1.2 | | 1.2 | |

NOTES: 7. Unless otherwise noted, the analog input is 0 dB, 1020-Hz sine wave, where 0 dB is defined as the zero-reference point of the channel under test.

8. The reference signal level, which is input to the transmit channel, is defined as a value 3 dB below the full-scale value of 88-mV_{rms}.

transmit gain and dynamic range, companded mode (μ -law or A-law) or linear mode selected, transmit slope filter enabled (see Notes 7 and 8)

| PARAMETER | TEST CONDITIONS | MIN | TYP | MAX | UNIT |
|---|--|------|-----|-----|------------------|
| Transmit reference-signal level (0dB) | Differential | | | 175 | mV _{pp} |
| Overload-signal level (3 dBm0) | Differential, normal mode | | | 248 | mV _{pp} |
| | Differential, extended mode | | | 63 | mV _{pp} |
| Absolute gain error | 0-dBm0 input signal, $V_{DD} = 2.7\text{ V}$ (minimum) | -1 | | 1 | dB |
| Gain error with input level relative to gain at -10-dBm0 MIC1N, MIC1P to PCMO | MIC1N, MIC1P to PCMO at 3 dBm0 to -30 dBm0 | -0.5 | | 0.5 | dB |
| | MIC1N, MIC1P to PCMO at -31 dBm0 to -45 dBm0 | -1 | | 1 | |
| | MIC1N, MIC1P to PCMO at -46 dBm0 to -55 dBm0 | -1.2 | | 1.2 | |

NOTES: 7. Unless otherwise noted, the analog input is 0 dB, 1020-Hz sine wave, where 0 dB is defined as the zero-reference point of the channel under test.

8. The reference signal level, which is input to the transmit channel, is defined as a value 3 dB below the full-scale value of 88-mV_{rms}.

transmit filter transfer, companded mode (μ -law or A-law) or linear mode selected, transmit slope filter bypassed, external high pass filter bypassed (MCLK = 2.048 MHz)

| PARAMETER | TEST CONDITIONS | MIN | TYP | MAX | UNIT |
|---|--|------|-----|-----|------|
| Gain relative to input signal gain at 1020 Hz, internal high-pass filter disabled | f_{MIC1} or $f_{MIC2} < 100\text{ Hz}$ | -0.5 | | 0.5 | dB |
| | f_{MIC1} or $f_{MIC2} = 200\text{ Hz}$ | -0.5 | | 0.5 | |
| | f_{MIC1} or $f_{MIC2} = 300\text{ Hz to }3\text{ kHz}$ | -0.5 | | 0.5 | |
| | f_{MIC1} or $f_{MIC2} = 3.4\text{ kHz}$ | -1.5 | | 0 | |
| | f_{MIC1} or $f_{MIC2} = 4\text{ kHz}$ | | | -14 | |
| | f_{MIC1} or $f_{MIC2} = 4.6\text{ kHz}$ | | | -35 | |
| | f_{MIC1} or $f_{MIC2} = 8\text{ kHz}$ | | | -47 | |
| Gain relative to input signal gain at 1020 Hz, internal high-pass filter enabled | f_{MIC1} or $f_{MIC2} < 100\text{ Hz}$ | | | -15 | dB |
| | f_{MIC1} or $f_{MIC2} = 200\text{ Hz}$ | | | -5 | |



electrical characteristics, $V_{DD} = 2.7\text{ V}$, $T_A = 25^\circ\text{ C}$ (unless otherwise noted) (continued)

transmit filter transfer, companded mode (μ -law or A-law) or linear mode selected, transmit slope filter selected (MCLK = 2.048 MHz) (see Note 9)

| PARAMETER | TEST CONDITIONS | MIN | TYP | MAX | UNIT |
|---|---|-----|-------|-----|------|
| Gain relative to input signal gain at 1000 Hz, with slope filter selected | f_{MIC1} or $f_{MIC2} = 100\text{ Hz}$ | | | -27 | dB |
| | f_{MIC1} or $f_{MIC2} = 200\text{ Hz}$ | | | -8 | dB |
| | f_{MIC1} or $f_{MIC2} = 250\text{ Hz}$ | | | -4 | dB |
| | f_{MIC1} or $f_{MIC2} = 300\text{ Hz}$ | | -1.80 | | dB |
| | f_{MIC1} or $f_{MIC2} = 400\text{ Hz}$ | | -1.50 | | dB |
| | f_{MIC1} or $f_{MIC2} = 500\text{ Hz}$ | | -1.30 | | dB |
| | f_{MIC1} or $f_{MIC2} = 600\text{ Hz}$ | | -1.1 | | dB |
| | f_{MIC1} or $f_{MIC2} = 700\text{ Hz}$ | | -0.8 | | dB |
| | f_{MIC1} or $f_{MIC2} = 800\text{ Hz}$ | | -0.57 | | dB |
| | f_{MIC1} or $f_{MIC2} = 900\text{ Hz}$ | | -0.25 | | dB |
| | f_{MIC1} or $f_{MIC2} = 1000\text{ Hz}$ | | 0 | | dB |
| | f_{MIC1} or $f_{MIC2} = 1500\text{ Hz}$ | | 1.8 | | dB |
| | f_{MIC1} or $f_{MIC2} = 2000\text{ Hz}$ | | 4.0 | | dB |
| | f_{MIC1} or $f_{MIC2} = 2500\text{ Hz}$ | | 6.5 | | dB |
| | f_{MIC1} or $f_{MIC2} = 3000\text{ Hz}$ | | 7.6 | | dB |
| | f_{MIC1} or $f_{MIC2} = 3100\text{ Hz}$ | | 7.7 | | dB |
| | f_{MIC1} or $f_{MIC2} = 3300\text{ Hz}$ | | 8.0 | | dB |
| | f_{MIC1} or $f_{MIC2} = 3500\text{ Hz}$ | | 6.48 | | dB |
| | f_{MIC1} or $f_{MIC2} = 4000\text{ Hz}$ | | | -13 | dB |
| | f_{MIC1} or $f_{MIC2} = 4500\text{ Hz}$ | | | -35 | dB |
| f_{MIC1} or $f_{MIC2} = 5000\text{ Hz}$ | | | -45 | dB | |
| f_{MIC1} or $f_{MIC2} = 8000\text{ Hz}$ | | | -50 | dB | |

NOTE 9: The pass-band tolerance is $\pm 0.25\text{ dB}$ from 300 Hz to 3500 Hz.

transmit idle channel noise and distortion, companded mode (μ -law or A-law) selected, slope filter bypassed

| PARAMETER | TEST CONDITIONS | MIN | TYP | MAX | UNIT |
|--|--|-----|-------|-----|-------------------|
| Transmit idle channel noise, psophometrically weighted | TXPGA gain = 0 dB, micamp 1 gain = 23.5 dB, micamp 2 gain = 0 dB | | -86.6 | -78 | dBm _{0p} |
| Transmit signal-to-distortion ratio with 1020-Hz sine-wave input | MIC1N, MIC1P to PCMO at 3 dBm ₀ | 27 | | | dB |
| | MIC1N, MIC1P to PCMO at 0 dBm ₀ | 30 | | | |
| | MIC1N, MIC1P to PCMO at -5 dBm ₀ | 33 | | | |
| | MIC1N, MIC1P to PCMO at -10 dBm ₀ | 36 | | | |
| | MIC1N, MIC1P to PCMO at -20 dBm ₀ | 35 | | | |
| | MIC1N, MIC1P to PCMO at -30 dBm ₀ | 26 | | | |
| | MIC1N, MIC1P to PCMO at -40 dBm ₀ | 24 | | | |
| Intermodulation distortion, 2-tone CCITT method, composite power level, -13 dBm ₀ | CCITT G.712 (7.1), R2 | 49 | | | dB |
| | CCITT G.712 (7.2), R2 | 51 | | | |

TWL1103

VOICE-BAND AUDIO PROCESSOR (VBAP™)

SLWS108A – JULY 2000 – JANUARY 2001

electrical characteristics, $V_{DD} = 2.7\text{ V}$, $T_A = 25^\circ\text{ C}$ (unless otherwise noted) (continued)

transmit idle channel noise and distortion, companded mode (μ -law or A-law) selected, slope filter enabled

| PARAMETER | TEST CONDITIONS | MIN | TYP | MAX | UNIT |
|--|--|-----|-------|-----|-------------------|
| Transmit idle channel noise, psophometrically weighted | TXPGA gain = 0 dB, micamp 1 gain = 23.5 dB, micamp 2 gain = 0.0 dB | | -86.6 | -78 | dBm _{0p} |
| Transmit signal-to-total distortion ratio with 1020-Hz sine-wave input | MIC1N, MIC1P to PCMO at 3 dBm ₀ | | 27 | | dB |
| | MIC1N, MIC1P to PCMO at 0 dBm ₀ | | 30 | | |
| | MIC1N, MIC1P to PCMO at -5 dBm ₀ | | 33 | | |
| | MIC1N, MIC1P to PCMO at -10 dBm ₀ | | 36 | | |
| | MIC1N, MIC1P to PCMO at -20 dBm ₀ | | 35 | | |
| | MIC1N, MIC1P to PCMO at -30 dBm ₀ | | 26 | | |
| | MIC1N, MIC1P to PCMO at -40 dBm ₀ | | 24 | | |
| Intermodulation distortion, 2-tone CCITT method, composite power level, -13 dBm ₀ | CCITT G.712 (7.1), R2 | | 49 | | dB |
| | CCITT G.712 (7.2), R2 | | 51 | | |

transmit idle channel noise and distortion, linear mode selected, slope filter bypassed

| PARAMETER | TEST CONDITIONS | MIN | TYP | MAX | UNIT |
|--|--|-----|-------|-----|-------------------|
| Transmit idle channel noise | TXPGA gain = 0 dB, micamp 1 gain = 23.5 dB, micamp 2 gain = 0.0 dB | | -86.6 | -78 | dBm _{0p} |
| Transmit signal-to-total distortion ratio with 1020-Hz sine-wave input | MIC1N, MIC1P to PCMO at 3 dBm ₀ | 40 | 50 | | dB |
| | MIC1N, MIC1P to PCMO at 0 dBm ₀ | 50 | 65 | | |
| | MIC1N, MIC1P to PCMO at -5 dBm ₀ | 60 | 68 | | |
| | MIC1N, MIC1P to PCMO at -10 dBm ₀ | 55 | 70 | | |
| | MIC1N, MIC1P to PCMO at -20 dBm ₀ | 58 | 65 | | |
| | MIC1N, MIC1P to PCMO at -30 dBm ₀ | 50 | 60 | | |
| | MIC1N, MIC1P to PCMO at -40 dBm ₀ | 38 | 50 | | |
| MIC1N, MIC1P to PCMO at -45 dBm ₀ | 30 | 45 | | | |

transmit idle channel noise and distortion, linear mode selected, slope filter enabled

| PARAMETER | TEST CONDITIONS | MIN | TYP | MAX | UNIT |
|--|--|-----|-------|-----|-------------------|
| Transmit idle channel noise | TXPGA gain = 0 dB, micamp 1 gain = 23.5 dB, micamp 2 gain = 0.0 dB | | -86.6 | -78 | dBm _{0p} |
| Transmit signal-to-total distortion ratio with 1020-Hz sine-wave input | MIC1N, MIC1P to PCMO at 3 dBm ₀ | 40 | 50 | | dB |
| | MIC1N, MIC1P to PCMO at 0 dBm ₀ | 50 | 65 | | |
| | MIC1N, MIC1P to PCMO at -5 dBm ₀ | 60 | 68 | | |
| | MIC1N, MIC1P to PCMO at -10 dBm ₀ | 55 | 70 | | |
| | MIC1N, MIC1P to PCMO at -20 dBm ₀ | 58 | 65 | | |
| | MIC1N, MIC1P to PCMO at -30 dBm ₀ | 50 | 60 | | |
| | MIC1N, MIC1P to PCMO at -40 dBm ₀ | 38 | 50 | | |
| MIC1N, MIC1P to PCMO at -45 dBm ₀ | 30 | 45 | | | |



electrical characteristics, $V_{DD} = 2.7\text{ V}$, $T_A = 25^\circ\text{ C}$ (unless otherwise noted) (continued)

receive gain and dynamic range, EAR1 selected, linear or companded (μ -law or A-law) mode selected (see Note 10)

| PARAMETER | TEST CONDITIONS | MIN | TYP | MAX | UNIT |
|---|--|------|------|-----|----------|
| Overload-signal level (3.0 dB) | 16- Ω load RXPGA = -2.0 dB | | 3.93 | | V_{pp} |
| | 32- Ω load RXPGA = -1.0 dB (default gain) | | 4.41 | | |
| Absolute gain error | 0-dBm0 input signal, $V_{DD} = 2.7\text{ V}$ (minimum) | -1 | | 1 | dB |
| Gain error with output level relative to gain at -10 dBm0 | PCMIN to EAR1ON, EAR1OP at 3 dBm0 to -40 dBm0 | -0.5 | | 0.5 | dB |
| | PCMIN to EAR1ON, EAR1OP at -41 dBm0 to -50 dBm0 | -1 | | 1 | |
| | PCMIN to EAR1ON, EAR1OP at -51 dBm0 to -55 dBm0 | -1.2 | | 1.2 | |

NOTE 10: RXPGA = -1 dB for 32 Ω default mode or RXPGA = -2 dB for 16 Ω , RXVOL = 0 dB, 1020 Hz input signal at PCMI, output measured differentially between EAR1ON and EAR1OP

receive gain and dynamic range, EAR2 selected, linear or companded (μ -law or A-law) mode selected (see Note 11)

| PARAMETER | TEST CONDITIONS | MIN | TYP | MAX | UNIT |
|---|--|------|-----|-----|----------|
| Receive reference-signal level (0 dB) | 0-dBm0 PCM input signal | | 1.1 | | V_{pp} |
| Overload-signal level (3 dB) | | | 1.6 | | V_{pp} |
| Absolute gain error | 0-dBm0 input signal, $V_{DD} = 2.7\text{ V}$ (minimum) | -1 | | 1 | dB |
| Gain error with output level relative to gain at -10 dBm0 | PCMIN to EAR2O at 3 dBm0 to -40 dBm0 | -0.5 | | 0.5 | dB |
| | PCMIN to EAR2O at -41 dBm0 to -50 dBm0 | -1 | | 1 | |
| | PCMIN to EAR2O at -51 dBm0 to -55 dBm0 | -1.2 | | 1.2 | |

NOTE 11: RXPGA = -1 dB, RXVOL = 0 dB

receive filter transfer, companded mode (μ -law or A-law) or linear mode selected (MCLK = 2.048 MHz) (see Note 11)

| PARAMETER | TEST CONDITIONS | MIN | TYP | MAX | UNIT |
|---|--|------|-----|-----|------|
| Gain relative to input signal gain at 1020 Hz, internal high-pass filter disabled | f_{EAR1} or $f_{EAR2} < 100\text{ Hz}$ | -0.5 | | 0.5 | dB |
| | f_{EAR1} or $f_{EAR2} = 200\text{ Hz}$ | -0.5 | | 0.5 | |
| | f_{EAR1} or $f_{EAR2} = 300\text{ Hz to }3\text{ kHz}$ | -0.5 | | 0.5 | |
| | f_{EAR1} or $f_{EAR2} = 3.4\text{ kHz}$ | -1.5 | | 0 | |
| | f_{EAR1} or $f_{EAR2} = 4\text{ kHz}$ | | | -14 | |
| | f_{EAR1} or $f_{EAR2} = 4.6\text{ kHz}$ | | | -35 | |
| | f_{EAR1} or $f_{EAR2} = 8\text{ kHz}$ | | | -47 | |
| Gain relative to input signal gain at 1020 Hz, internal high-pass filter enabled | f_{EAR1} or $f_{EAR2} < 100\text{ Hz}$ | | | -15 | dB |
| | f_{EAR1} or $f_{EAR2} = 200\text{ Hz}$ | | | -5 | |

NOTE 11: RXPGA = -1 dB, RXVOL = 0 dB

TWL1103

VOICE-BAND AUDIO PROCESSOR (VBAP™)

SLWS108A – JULY 2000 – JANUARY 2001

electrical characteristics, $V_{DD} = 2.7\text{ V}$, $T_A = 25^\circ\text{ C}$ (unless otherwise noted) (continued)

receive idle channel noise and distortion, EAR1 selected, companded mode (μ -law or A-law) selected (see Note 12)

| PARAMETER | TEST CONDITIONS | MIN | TYP | MAX | UNIT |
|---|-------------------------------------|-----|-----|-----|----------------------------|
| Receive noise, psophometrically weighted | PCMIN = 11010101 (A-law) | | -89 | -86 | dBm _{0p} |
| Receive noise, C-message weighted | PCMIN = 11111111 (μ -law) | | 36 | 50 | μV_{rms} |
| Receive signal-to-distortion ratio with 1020-Hz sine-wave input | PCMIN to EAR1ON, EAR1OP at 3 dBm0 | 21 | | | dB |
| | PCMIN to EAR1ON, EAR1OP at 0 dBm0 | 25 | | | |
| | PCMIN to EAR1ON, EAR1OP at -5 dBm0 | 36 | | | |
| | PCMIN to EAR1ON, EAR1OP at -10 dBm0 | 43 | | | |
| | PCMIN to EAR1ON, EAR1OP at -20 dBm0 | 40 | | | |
| | PCMIN to EAR1ON, EAR1OP at -30 dBm0 | 38 | | | |
| | PCMIN to EAR1ON, EAR1OP at -40 dBm0 | 28 | | | |
| | PCMIN to EAR1ON, EAR1OP at -45 dBm0 | 23 | | | |

NOTE 12: RXPGA = -1 dB for 32 Ω default mode or RXPGA = -2 dB for 16 Ω , RXVOL = 0 dB, 1020 Hz input signal at PCMI, output measured differentially between EAR1ON and EAR1OP.

receive idle channel noise and distortion, EAR1 selected, linear mode selected (see Note 12)

| PARAMETER | TEST CONDITIONS | MIN | TYP | MAX | UNIT |
|--|-------------------------------------|-----|-----|-----|------|
| Receive noise, (20 Hz to 20 kHz brickwall window) | PCMIN = 000000000000 | | -86 | -83 | dBm0 |
| Receive signal-to-distortion ratio with 1020 Hz sine-wave input | PCMIN to EAR1ON, EAR1OP at 3 dBm0 | 65 | 78 | | dB |
| | PCMIN to EAR1ON, EAR1OP at 0 dBm0 | 73 | 80 | | |
| | PCMIN to EAR1ON, EAR1OP at -5 dBm0 | 72 | 78 | | |
| | PCMIN to EAR1ON, EAR1OP at -10 dBm0 | 70 | 78 | | |
| | PCMIN to EAR1ON, EAR1OP at -20 dBm0 | 60 | 76 | | |
| | PCMIN to EAR1ON, EAR1OP at -30 dBm0 | 50 | 67 | | |
| | PCMIN to EAR1ON, EAR1OP at -40 dBm0 | 40 | 60 | | |
| Intermodulation distortion, 2-tone CCITT method, composite power level, -13 dBm0 | CCITT G.712 (7.1), R2 | 50 | | | dB |
| | CCITT G.712 (7.2), R2 | 54 | | | |

NOTE 12: RXPGA = -1 dB for 32 Ω default mode or RXPGA = -2 dB for 16 Ω , RXVOL = 0 dB, 1020 Hz input signal at PCMI, output measured differentially between EAR1ON and EAR1OP.

receive idle channel noise and distortion, EAR2 selected, companded mode (μ -law or A-law) selected (see Note 11)

| PARAMETER | TEST CONDITIONS | MIN | TYP | MAX | UNIT |
|---|--------------------------------|-----|-----|-----|----------------------------|
| Receive noise, psophometrically weighted | PCMIN = 11010101 (A-law) | | -81 | -78 | dBm _{0p} |
| Receive noise, C-message weighted | PCMIN = 11111111 (μ -law) | | 36 | 50 | μV_{rms} |
| Receive signal-to-distortion ratio with 1020-Hz sine-wave input | PCMIN to EAR2O at 3 dBm0 | 21 | | | dB |
| | PCMIN to EAR2O at 0 dBm0 | 25 | | | |
| | PCMIN to EAR2O at -5 dBm0 | 36 | | | |
| | PCMIN to EAR2O at -10 dBm0 | 43 | | | |
| | PCMIN to EAR2O at -20 dBm0 | 40 | | | |
| | PCMIN to EAR2O at -30 dBm0 | 38 | | | |
| | PCMIN to EAR2O at -40 dBm0 | 28 | | | |
| | PCMIN to EAR2O at -45 dBm0 | 23 | | | |

NOTE 11: RXPGA = -1 dB, RXVOL = 0 dB



electrical characteristics, $V_{DD} = 2.7\text{ V}$, $T_A = 25^\circ\text{ C}$ (unless otherwise noted) (continued)

receive idle channel noise and distortion, EAR2 selected, linear mode selected (see Note 11)

| PARAMETER | TEST CONDITIONS | MIN | TYP | MAX | UNIT |
|--|----------------------------|-----|-----|-----|------|
| Receive noise, (20 Hz to 20 kHz brickwall window) | PCMIN = 000000000000 | -86 | | -83 | dBm0 |
| Receive signal-to-distortion ratio with 1020-Hz sine-wave input | PCMIN to EAR2O at 3 dBm0 | 45 | 60 | | dB |
| | PCMIN to EAR2O at 0 dBm0 | 60 | 65 | | |
| | PCMIN to EAR2O at -5 dBm0 | 58 | 62 | | |
| | PCMIN to EAR2O at -10 dBm0 | 55 | 60 | | |
| | PCMIN to EAR2O at -20 dBm0 | 53 | 60 | | |
| | PCMIN to EAR2O at -30 dBm0 | 52 | 58 | | |
| | PCMIN to EAR2O at -40 dBm0 | 50 | 57 | | |
| Intermodulation distortion, 2-tone CCITT method, composite power level, -13 dBm0 | CCITT G.712 (7.1), R2 | 50 | | | dB |
| | CCITT G.712 (7.2), R2 | 54 | | | |

NOTE 11: RXPGA = -1 dB, RXVOL = 0 dB

power supply rejection and crosstalk attenuation

| PARAMETER | TEST CONDITIONS | MIN | TYP | MAX | UNIT |
|---|--|-----|-----|-----|------|
| Supply voltage rejection, transmit channel | MIC1N, MIC1P = 0 V, $V_{DD} = 2.7\text{ V} + 100\text{ mV}_{\text{peak to peak}}$, $f = 0\text{ to }50\text{ kHz}$ | -80 | | -45 | dB |
| Supply voltage rejection, receive channel, EAR1 selected (differential) | PCM code = positive zero, $V_{DD} = 2.7\text{ V} + 100\text{ mV}_{\text{peak to peak}}$, $f = 0\text{ to }50\text{ kHz}$ | -90 | | -45 | dB |
| Crosstalk attenuation, transmit-to-receive (differential) | MIC1N, MIC1P = 0 dB, $f = 300\text{ to }3400\text{ Hz}$ measured differentially between EAR1ON and EAR1OP | 70 | | | dB |
| Crosstalk attenuation, receive-to-transmit | PCMIN = 0 dBm0, $f = 300\text{ to }3400\text{ Hz}$ measured at PCMO, EAR1 amplifier | 70 | | | dB |

DTMF generator

| PARAMETER | TEST CONDITIONS | MIN | TYP | MAX | UNIT |
|--|---|--------|-----|-------|------|
| DTMF high to low tone relative amplitude (preemphasis) | | 1.5 | 2 | 2.5 | dB |
| Tone frequency accuracy | | -1.5 % | | 1.5 % | |
| Harmonic distortion | Measured from lower tone group to highest parasitic | | | -20 | dB |

MICBIAS

| PARAMETER | TEST CONDITIONS | MIN | TYP | MAX | UNIT |
|----------------|-----------------|-----|-----|-----|------------|
| Load impedance | | 2.0 | | 2.5 | k Ω |

TWL1103 VOICE-BAND AUDIO PROCESSOR (VBAP™)

SLWS108A – JULY 2000 – JANUARY 2001

timing requirements

clock

| | MIN | NOM | MAX | UNIT |
|--|-------|-----|-------|------|
| t_t Transition time, MCLK | | | 10 | ns |
| MCLK frequency | 2.048 | | 2.048 | MHz |
| MCLK jitter | | | 37% | |
| Number of PCMCLK clock cycles per PCMSYN frame | 256 | | 256 | |
| $t_c(\text{PCMCLK})$ PCMCLK clock period | 156 | 488 | 512 | ns |
| Duty cycle, PCMCLK | 45% | 50% | 68% | |

transmit (see Figure 6)

| | MIN | MAX | UNIT |
|--|-----|---------------------------|------|
| $t_{su}(\text{PCMSYN})$ Setup time, PCMSYN high before PCMCLK↓ | 20 | $t_c(\text{PCMCLK}) - 20$ | ns |
| $t_h(\text{PCMSYN})$ Hold time, PCMSYN high after PCMCLK↓ | 20 | $t_c(\text{PCMCLK}) - 20$ | |

receive (see Figure 5)

| | MIN | MAX | UNIT |
|---|-----|---------------------------|------|
| $t_{su}(\text{PCSYN})$ Setup time, PCMSYN high before PCMCLK↓ | 20 | $t_c(\text{PCMCLK}) - 20$ | ns |
| $t_h(\text{PCSYN})$ Hold time, PCMSYN high after PCMCLK↓ | 20 | $t_c(\text{PCMCLK}) - 20$ | ns |
| $t_{su}(\text{PCMI})$ Setup time, PCMI high or low before PCMCLK↓ | 20 | | ns |
| $t_h(\text{PCMI})$ Hold time, PCMI high or low after PCMCLK↓ | 20 | | ns |

I²C bus (see Figure 6)

| | MIN | MAX | UNIT |
|--|------|-----|------|
| SCL Clock frequency | | 400 | kHz |
| t_{HIGH} Clock high time | 600 | | ns |
| t_{LOW} Clock low time | 1300 | | ns |
| t_R SDA and SCL rise time | | 300 | ns |
| t_F SDA and SCL fall time | | 300 | ns |
| $t_{HD:STA}$ Hold time (repeated) START condition. After this period the first clock pulse is generated. | 600 | | ns |
| $t_{su:STA}$ Setup time for repeated START condition | 600 | | ns |
| $t_{HD:DAT}$ Data input hold time | 0 | | ns |
| $t_{su:DAT}$ Data input setup time | 100 | | ns |
| $t_{su:STO}$ STOP condition setup time | 600 | | ns |
| t_{BUF} Bus free time | 1300 | | ns |

switching characteristics

propagation delay times, $C_{Lmax} = 10$ pF (see Figure 5)

| | MIN | MAX | UNIT |
|---|-----|-----|------|
| t_{pd1} From PCMCLK bit 1 high to PCMO bit 1 valid | | 35 | ns |
| t_{pd2} From PCMCLK high to PCMO valid, bits 2 to n | | 35 | ns |
| t_{pd3} From PCMCLK bit n low to PCMO bit n Hi-Z | 30 | | ns |



PARAMETER MEASUREMENT INFORMATION

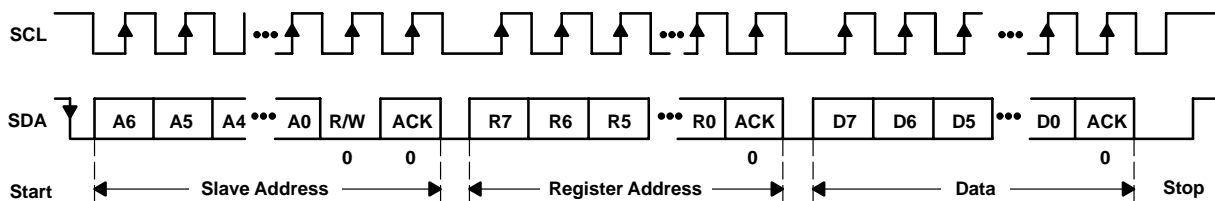

NOTE: SLAVE = VBAP

Figure 1. I²C Bus Write to VBAP

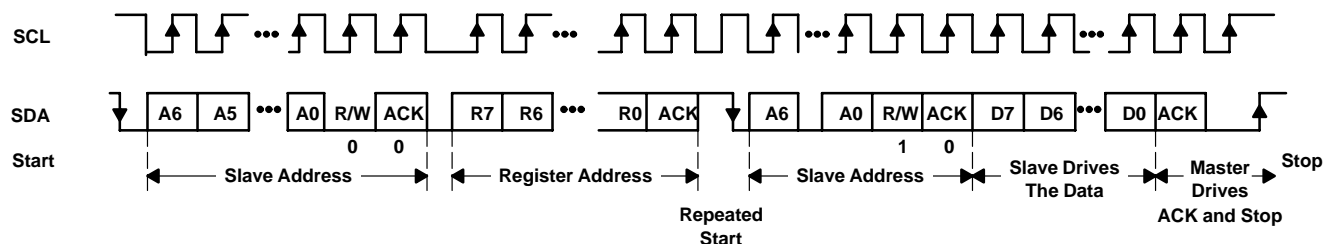

NOTE: SLAVE = VBAP

Figure 2. I²C Read From VBAP: Protocol A

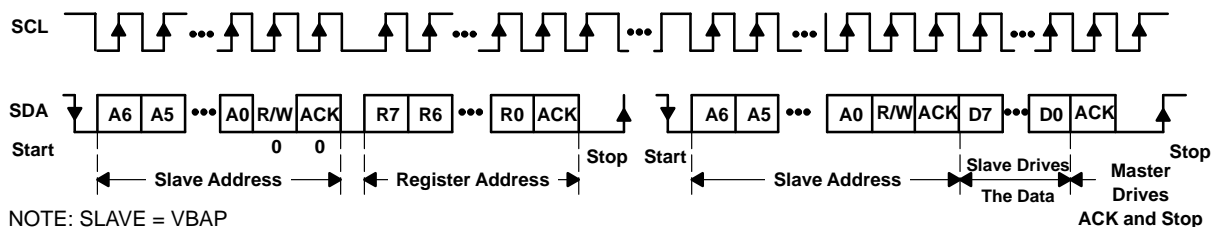

NOTE: SLAVE = VBAP

Figure 3. I²C Read From VBAP: Protocol B

TWL1103 VOICE-BAND AUDIO PROCESSOR (VBAP™)

SLWS108A – JULY 2000 – JANUARY 2001

PARAMETER MEASUREMENT INFORMATION

register map addressing

| | REG | 07 | 06 | 05 | 04 | 03 | 02 | 01 | 00 |
|---------------|-----|-------------|-------------|-------------|-------------|-------------|-------------|-------------|-------------|
| Power control | 00 | Sidetone En | TXEn | RXEn | MICSEL | BIASEn | RXEn | EAROUT Sel | PWRUP |
| Mode control | 01 | Comp Sel | TMEEn | PCMLB | Comp En | BUZZEn | RXFLTR En | TXFLTR En | TXSLOPE En |
| TXPGA | 02 | PD0 | TP3 | TP2 | TP1 | TP0 | ST2 | ST1 | ST0 |
| RXPGA | 03 | RP3 | RP2 | RP1 | RP0 | RV3 | RV2 | RV1 | RV0 |
| High DTMF | 04 | HIFREQ Sel7 | HIFREQ Sel6 | HIFREQ Sel5 | HIFREQ Sel4 | HIFREQ Sel3 | HIFREQ Sel2 | HIFREQ Sel1 | HIFREQ Sel0 |
| Low DTMF | 05 | LOFREQ Sel7 | LOFREQ Sel6 | LOFREQ Sel5 | LOFREQ Sel4 | LOFREQ Sel3 | LOFREQ Sel2 | LOFREQ Sel1 | LOFREQ Sel0 |

register power-up defaults

| | REG | 07 | 06 | 05 | 04 | 03 | 02 | 01 | 00 |
|----------------|-----|----|----|----|----|----|----|----|----|
| Power control† | 00 | 1 | 1 | 1 | 1 | 0 | 1 | 1 | 0 |
| Power control‡ | 00 | 1 | 0 | 0 | 1 | 1 | 0 | 1 | 1 |
| Mode control | 01 | 0 | 0 | 0 | 0 | 0 | 0 | 1 | 0 |
| TXPGA | 02 | 0 | 1 | 0 | 0 | 0 | 0 | 0 | 0 |
| RXPGA | 03 | 0 | 1 | 1 | 1 | 0 | 0 | 0 | 0 |
| High DTMF | 04 | 0 | 0 | 0 | 0 | 0 | 0 | 0 | 0 |
| Low DTMF | 05 | 0 | 0 | 0 | 0 | 0 | 0 | 0 | 0 |

† Value when PWRUPSEL = 0

‡ Value when PWRUPSEL = 1



PARAMETER MEASUREMENT INFORMATION

register map

Table 1. Power Control Register: Address {00} HEX

| BIT NUMBER | | | | | | | | DEFINITIONS |
|------------|---|---|---|---|---|---|---|--|
| 7 | 6 | 5 | 4 | 3 | 2 | 1 | 0 | |
| 1 | 1 | 1 | 1 | 0 | 1 | 1 | 0 | Default setting PWRUPSEL = 0 |
| 1 | 0 | 0 | 1 | 1 | 0 | 1 | 1 | Default setting PWRUPSEL = 1 |
| X | X | X | X | X | X | X | 0 | Reference system, power down |
| X | X | X | X | X | X | X | 1 | Reference system, power up |
| X | X | X | X | X | X | 1 | X | EAR AMP1 selected, EAR AMP2 power down |
| X | X | X | X | X | X | 0 | X | EAR AMP2 selected, EAR AMP1 power down |
| X | X | X | X | X | 0 | X | X | Receive channel enabled |
| X | X | 0 | X | X | 1 | X | X | Receive channel muted |
| X | X | 1 | X | X | 1 | X | 0 | Receive channel, power down |
| X | X | X | X | 1 | X | X | X | MICBIAS selected |
| X | X | X | X | 0 | X | X | X | MICBIAS power down |
| X | X | X | 1 | X | X | X | X | MIC1 selected |
| X | X | X | 0 | X | X | X | X | MIC2 selected |
| X | 0 | X | X | X | X | X | X | Transmit channel enabled |
| X | 1 | 0 | X | X | X | X | X | Transmit channel muted |
| X | 1 | 1 | X | X | X | X | X | Transmit channel power down |
| 0 | X | X | X | X | X | X | X | Sidetone enabled |
| 1 | X | X | X | X | X | X | X | Sidetone muted |

Table 2. Mode Control Register: Address {01} HEX

| BIT NUMBER | | | | | | | | DEFINITIONS |
|------------|---|---|---|---|---|---|---|--|
| 7 | 6 | 5 | 4 | 3 | 2 | 1 | 0 | |
| 0 | 0 | 0 | 0 | 0 | 0 | 1 | 0 | Default setting |
| X | X | X | X | X | X | 0 | 0 | TX channel high-pass filter enabled and slope filter enabled |
| X | X | X | X | X | X | 0 | 1 | TX channel high-pass filter enabled and slope filter disabled |
| X | X | X | X | X | X | 1 | 0 | TX channel high-pass filter disabled and slope filter enabled |
| X | X | X | X | X | X | 1 | 1 | TX channel high-pass filter disabled and slope filter disabled |
| X | X | X | X | X | 0 | X | X | RX channel high-pass filter disabled (low pass only) |
| X | X | X | X | X | 1 | X | X | RX channel high-pass filter enabled |
| X | X | X | X | 0 | X | X | X | BUZZCON disabled |
| X | X | X | X | 1 | X | X | X | BUZZCON enabled |
| X | X | X | 0 | X | X | X | X | Linear mode selected |
| 1 | X | X | 1 | X | X | X | X | A-law companding mode selected |
| 0 | X | X | 1 | X | X | X | X | μ-law companding mode selected |
| X | X | 0 | X | X | X | X | X | TX and RX channels normal mode |
| X | X | 1 | X | X | X | X | X | PCM loopback mode |
| X | 0 | X | X | X | X | X | X | Tone mode disabled |
| X | 1 | X | X | X | X | X | X | Tone mode enabled |

PARAMETER MEASUREMENT INFORMATION

Transmit PGA and sidetone control register: Address {02}HEX

Bit definitions:

| 7 | 6 | 5 | 4 | 3 | 2 | 1 | 0 | DEFINITION |
|-----|-----|-----|-----|-----|-----|-----|-----|-------------------------|
| PDO | TP3 | TP2 | TP1 | TP0 | ST2 | ST1 | ST0 | See Table 2 and Table 4 |
| 0 | 1 | 0 | 0 | 0 | 0 | 0 | 0 | Default setting |

Receive volume control register: Address {03}HEX

Bit definitions :

| 7 | 6 | 5 | 4 | 3 | 2 | 1 | 0 | DEFINITION |
|-----|-----|-----|-----|-----|-----|-----|-----|-------------------------|
| RP3 | RP2 | RP1 | RP0 | RV3 | RV2 | RV1 | RV0 | See Table 3 and Table 5 |
| 0 | 1 | 1 | 1 | 0 | 0 | 0 | 0 | Default setting |

High tone selection control register: Address {04}HEX

Bit definitions:

| 7 | 6 | 5 | 4 | 3 | 2 | 1 | 0 | DEFINITION |
|---|---|---|---|---|---|---|---|--------------------|
| X | X | X | X | X | X | X | X | DTMF (see Table 7) |
| 0 | 0 | 0 | 0 | 0 | 0 | 0 | 0 | Default setting |

Low tone selection control register: Address {05}HEX

Bit definitions:

| 7 | 6 | 5 | 4 | 3 | 2 | 1 | 0 | DEFINITION |
|---|---|---|---|---|---|---|---|--------------------|
| X | X | X | X | X | X | X | X | DTMF (see Table 7) |
| 0 | 0 | 0 | 0 | 0 | 0 | 0 | 0 | Default setting |

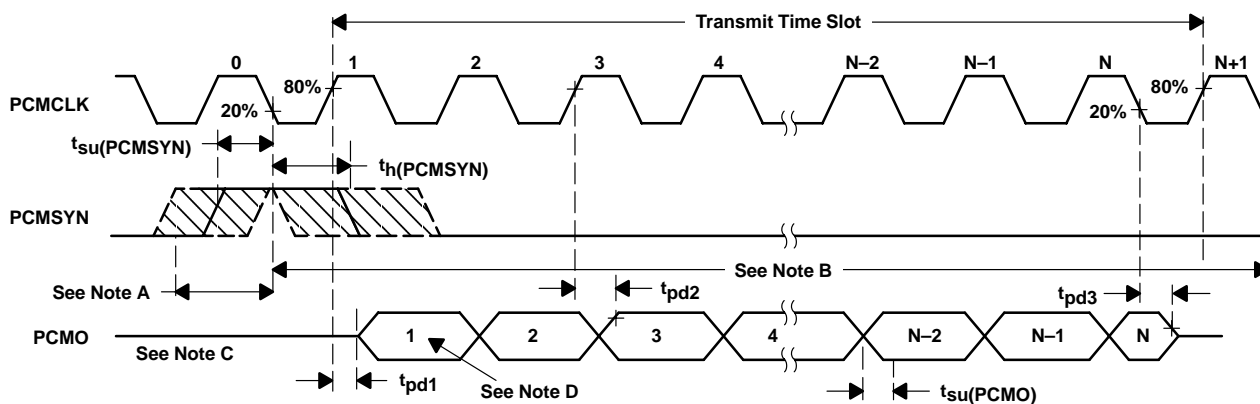

- NOTES: A. This window is allowed for PCMSYN high.
 B. This window is allowed for PCMSYN low ($t_h(PCMSYN)_{max}$ determined by data collision considerations).
 C. Transitions are measured at 50%.
 D. Bit 1 = MSB, Bit N = LSB

Figure 4. Transmit Timing Diagram

PARAMETER MEASUREMENT INFORMATION

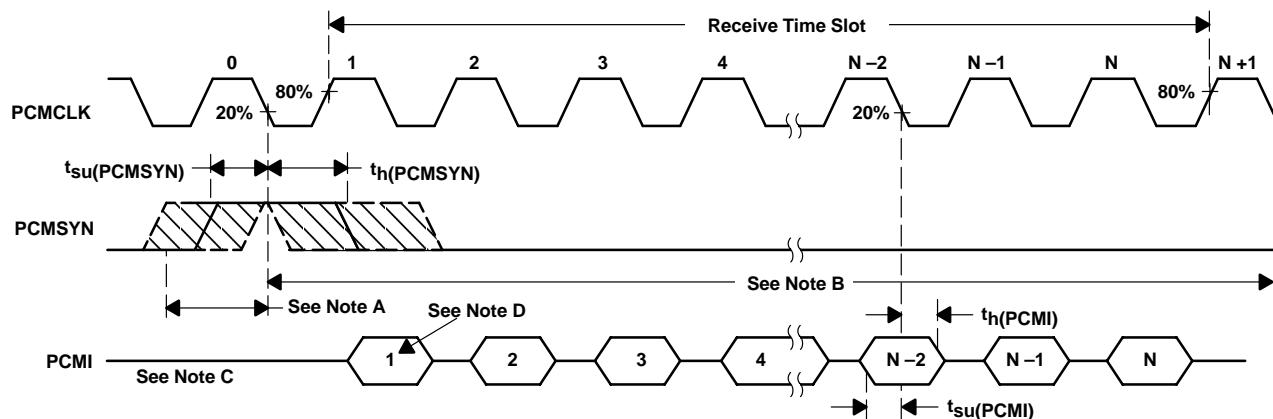

- A. This window is allowed for PCMSYN high.
- B. This window is allowed for PCMSYN low.
- C. Transitions are measured at 50%.
- D. Bit 1 = MSB, Bit N = LSB

Figure 5. Receive Timing Diagram

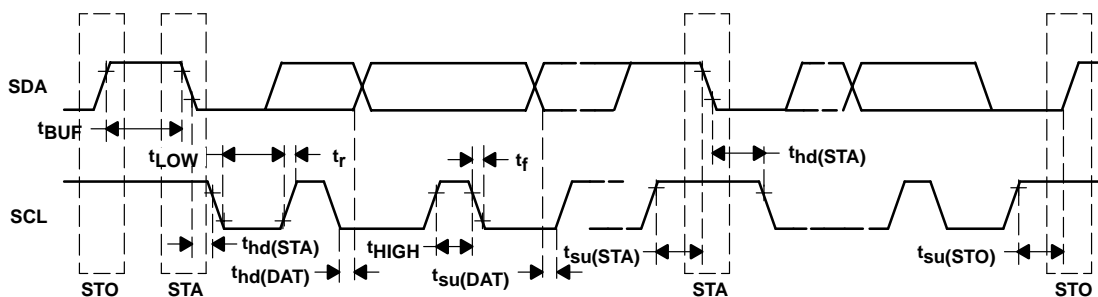

Figure 6. I²C Bus Timing Diagram

PRINCIPLES OF OPERATION

power-on initialization

An external reset with a minimum pulse width of 500 ns must be applied to the active low $\overline{\text{RESET}}$ terminal to guarantee reset upon power on. All registers are set with default values upon external reset initialization.

The desired selection for all programmable functions can be initialized prior to a power-up command using the I²C interface.

Table 3. Power-Up and Power-Down Procedures ($V_{DD} = 2.7 \text{ V}$, Earphone amplifier unloaded)

| DEVICE STATUS | PROCEDURE | MAXIMUM POWER CONSUMPTION |
|---------------|---|---------------------------|
| Power up | Set bit 1 = 1 in power control register, EAR1 enabled | 16.2 mW |
| | Set bit 1 = 0 in power control register, EAR2 enabled | 14.6 mW |
| Power down | Set bit 7 = 1 in TXPGA control register and bit 0 = 0 | 1.35 μW |
| | Set bit 7 = 0 in TXPGA control register and bit 0 = 0 | 67.5 μW |

In addition to resetting the power-down bit in the power control register, loss of MCLK (no transition detected) automatically enters the device into a power-down state with PCMO in the high impedance state. If during a pulse code modulation (PCM) data transmit cycle an asynchronous power down occurs, the PCM interface remains powered up until the PCM data is completely transferred.

An additional power-down mode overrides the MCLK detection function. This allows the device to enter the power-down state without regard to MCLK. Setting bit 7 of the TX filter and PGA sidetone register to logic high enables this function.

conversion laws

The device can be programmed either for a 15-bit linear or 8-bit (μ -law or A-law) companding mode. The companding operation approximates the CCITT G.711 recommendation. The linear mode operation uses a 15-bit twos-complement format.

transmit operation

microphone input

The microphone input stage is a low noise differential amplifier that provides a preamplifier gain of 23.5 dB. A microphone can be capacitively connected to the MIC1N and MIC1P inputs, while the MIC2N and MIC2P inputs can be used to capacitively connect a second microphone or an auxiliary audio circuit.



PRINCIPLES OF OPERATION

transmit operation (continued)

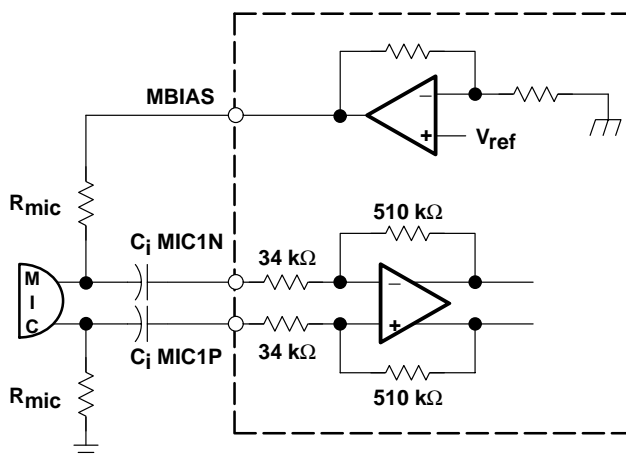

Figure 7. Typical Microphone Interface

microphone mute function

Transmit channel muting provides 80-dB attenuation of input microphone signal. The MICMUTE function can be selected by setting bit 6 of the power control register through the I²C interface.

transmit channel gain control

The values in the transmit PGA control registers control the gain in the transmit path. The total TX channel gain can vary from 35.5 dB to 13.5 dB. The default total TX channel gain is 23.5 dB

Table 4. Transmit Gain Control

| BIT NAME | | | | MIC AMP1 | MIC AMP2 | TX PGA | GAIN MODE | TOTAL TX GAIN | | | |
|----------|-----|-----|-----|----------|----------|--------|-----------|---------------|------|------|------|
| TP3 | TP2 | TP1 | TP0 | GAIN | GAIN | GAIN | | MIN | TYP | MAX | UNIT |
| 0 | 0 | 0 | 0 | 23.5 | 12 | 0 | Extended | 35.3 | 35.5 | 35.7 | dB |
| 0 | 0 | 0 | 1 | 23.5 | 12 | -2 | Extended | 33.3 | 33.5 | 33.7 | dB |
| 0 | 0 | 1 | 0 | 23.5 | 12 | -4 | Extended | 31.3 | 31.5 | 31.7 | dB |
| 0 | 0 | 1 | 1 | 23.5 | 12 | -6 | Extended | 29.3 | 29.5 | 29.7 | dB |
| 0 | 1 | 0 | 0 | 23.5 | 12 | -8 | Extended | 27.3 | 27.5 | 27.7 | dB |
| 0 | 1 | 0 | 1 | 23.5 | 12 | -10 | Extended | 25.3 | 25.5 | 25.7 | dB |
| 1 | 0 | 0 | 0 | 23.5 | 0 | 0 | Normal | 23.3 | 23.5 | 23.7 | dB |
| 1 | 0 | 0 | 1 | 23.5 | 0 | -2 | Normal | 21.3 | 21.5 | 21.7 | dB |
| 1 | 0 | 1 | 0 | 23.5 | 0 | -4 | Normal | 19.3 | 19.5 | 19.7 | dB |
| 1 | 0 | 1 | 1 | 23.5 | 0 | -6 | Normal | 17.3 | 17.5 | 17.7 | dB |
| 1 | 1 | 0 | 0 | 23.5 | 0 | -8 | Normal | 15.3 | 17.5 | 17.7 | dB |
| 1 | 1 | 0 | 1 | 23.5 | 0 | -10 | Normal | 13.3 | 13.5 | 13.7 | dB |

PRINCIPLES OF OPERATION

receive operation

receive channel gain control

The values in the receive PGA control registers control the gain in the receive path. PGA gain is set from –6 dB to 6 dB in 1-dB steps through the I²C interface. The default receive channel gain is –1 dB.

Table 5. Receive PGA Gain Control

| BIT NAME | | | | RELATIVE GAIN | | | |
|----------|-----|-----|-----|---------------|-----|------|------|
| RP3 | RP2 | RP1 | RP0 | MIN | TYP | MAX | UNIT |
| 0 | 0 | 0 | 0 | 5.8 | 6 | 6.2 | dB |
| 0 | 0 | 0 | 1 | 4.8 | 5 | 5.2 | dB |
| 0 | 0 | 1 | 0 | 3.8 | 4 | 4.2 | dB |
| 0 | 0 | 1 | 1 | 2.8 | 3 | 3.2 | dB |
| 0 | 1 | 0 | 0 | 1.8 | 2 | 2.2 | dB |
| 0 | 1 | 0 | 1 | 0.8 | 1 | 1.2 | dB |
| 0 | 1 | 1 | 0 | -0.2 | 0 | 0.2 | dB |
| 0 | 1 | 1 | 1 | -1.2 | -1 | -0.8 | dB |
| 1 | 0 | 0 | 0 | -2.2 | -2 | -1.8 | dB |
| 1 | 0 | 0 | 1 | -3.2 | -3 | -2.8 | dB |
| 1 | 0 | 1 | 0 | -4.2 | -4 | -3.8 | dB |
| 1 | 0 | 1 | 1 | -5.2 | -5 | -4.8 | dB |
| 1 | 1 | 0 | 0 | -6.2 | -6 | -5.8 | dB |

sidetone gain control

The values in the sidetone PGA control registers control the sidetone gain. Sidetone gain is set from –12 dB to –24 dB in 2-dB steps through the I²C interface. Sidetone can be muted by setting bit 7 of the power control register. The default sidetone gain is –12 dB.

Table 6. Sidetone Gain Control

| BIT NAME | | | RELATIVE GAIN | | | |
|----------|-----|-----|---------------|-----|-------|------|
| ST2 | ST1 | ST0 | MIN | TYP | MAX | UNIT |
| 0 | 0 | 0 | -12.2 | -12 | -11.8 | dB |
| 0 | 0 | 1 | -14.2 | -14 | -13.8 | dB |
| 0 | 1 | 0 | -16.2 | -16 | -15.8 | dB |
| 0 | 1 | 1 | -18.2 | -18 | -17.8 | dB |
| 1 | 0 | 0 | -20.2 | -20 | -19.8 | dB |
| 1 | 0 | 1 | -22.2 | -22 | -21.8 | dB |
| 1 | 1 | 0 | -24.2 | -24 | -23.8 | dB |

PRINCIPLES OF OPERATION

receive operation (continued)

receive volume control

The values in the volume control PGA control registers provide volume control into the earphone. Volume control gain is set from 0 dB to –18 dB in 2-dB steps through the I²C interface. The default RX volume control gain is 0 dB.

Table 7. rx Volume Control

| BIT NAME | | | | RELATIVE GAIN | | | |
|----------|-----|-----|-----|---------------|-----|-------|------|
| RV3 | RV2 | RV1 | RV0 | MIN | TYP | MAX | UNIT |
| 0 | 0 | 0 | 0 | –0.2 | 0 | 0.2 | dB |
| 0 | 0 | 0 | 1 | –2.2 | –2 | –1.8 | dB |
| 0 | 0 | 1 | 0 | –4.2 | –4 | –3.8 | dB |
| 0 | 0 | 1 | 1 | –6.2 | –6 | –5.8 | dB |
| 0 | 1 | 0 | 0 | –8.2 | –8 | –7.8 | dB |
| 0 | 1 | 0 | 1 | –10.2 | –10 | –9.8 | dB |
| 0 | 1 | 1 | 0 | –12.2 | –12 | –11.8 | dB |
| 0 | 1 | 1 | 1 | –14.2 | –14 | –13.8 | dB |
| 1 | 0 | 0 | 0 | –16.2 | –16 | –15.8 | dB |
| 1 | 0 | 0 | 1 | –18.2 | –18 | –17.8 | dB |

earphone amplifier

The analog signal can be routed to one of two earphone amplifiers: one with differential output (EAR1ON and EAR1OP) capable of driving a 16-Ω load or one with single-ended output (EAR2O) capable of driving a 32-Ω load.

earphone mute function

Muting can be selected by setting bit 3 of the power control register through the I²C interface.

receive PCM data format

- Companded mode: eight bits are received, the most significant (MSB) first.
- Linear mode: 15 bits are received, MSB first.

PRINCIPLES OF OPERATION

receive operation (continued)

Table 8. Receive-Data Bit Definitions

| BIT NO. | COMPANDED MODE | LINEAR MODE |
|----------------|-----------------------|--------------------|
| 1 | CD7 | LD14 |
| 2 | CD6 | LD13 |
| 3 | CD5 | LD12 |
| 4 | CD4 | LD11 |
| 5 | CD3 | LD10 |
| 6 | CD2 | LD9 |
| 7 | CD1 | LD8 |
| 8 | CD0 | LD7 |
| 9 | – | LD6 |
| 10 | – | LD5 |
| 11 | – | LD4 |
| 12 | – | LD3 |
| 13 | – | LD2 |
| 14 | – | LD1 |
| 15 | – | LD0 |
| 16 | – | — |

Transmit channel gain control bits always follow the PCM data in time:

CD7–CD0 = data word in companded mode

LD14–LD0 = data word in linear mode

DTMF generator operation and interface

The dual-tone multifrequency generator (DTMF) circuit generates the summed DTMF tones for push button dialing and provides the PDM output for the BUZZCON user-alert tone. There are 255 possible single tones. The tone integer value is determined by the formula:

Round (tone frequency (Hz)/7.8125 Hz)

The integer value is loaded into either one of two 8-bit registers, high-tone register (04), or low-tone register (05). The tone output is 2 dB higher when applied to the high-tone register (04). When generating DTMF tones, the high frequency value must be applied to the high-tone register (04) and the low DTMF value to the low-tone register.

PRINCIPLES OF OPERATION

DTMF generator operation and interface (continued)

Table 9. Typical DTMF and Single Tone Control

| DT7 | DT6 | DT5 | DT4 | DT3 | DT2 | DT1 | DT0 | INTEGER VALUE | TONE FUNCTION | TONE/Hz |
|-----|-----|-----|-----|-----|-----|-----|-----|---------------|---------------|---------|
| 0 | 0 | 0 | 0 | 0 | 0 | 0 | 0 | 0 | OFF | 0 |
| 0 | 0 | 1 | 0 | 1 | 1 | 0 | 1 | 45 | F | 349 |
| 0 | 0 | 1 | 0 | 1 | 1 | 1 | 1 | 47 | F# | 370 |
| 0 | 0 | 1 | 1 | 0 | 0 | 1 | 0 | 50 | G | 392 |
| 0 | 0 | 1 | 1 | 0 | 1 | 0 | 1 | 53 | G# | 415 |
| 0 | 0 | 1 | 1 | 1 | 0 | 0 | 0 | 56 | A | 440 |
| 0 | 0 | 1 | 1 | 1 | 1 | 0 | 0 | 60 | A# | 466 |
| 0 | 0 | 1 | 1 | 1 | 1 | 1 | 1 | 63 | B | 494 |
| 0 | 1 | 0 | 0 | 0 | 0 | 1 | 1 | 67 | C | 523 |
| 0 | 1 | 0 | 0 | 0 | 1 | 1 | 1 | 71 | C# | 554 |
| 0 | 1 | 0 | 0 | 1 | 0 | 1 | 1 | 75 | D | 587 |
| 0 | 1 | 0 | 1 | 0 | 0 | 0 | 0 | 80 | D# | 622 |
| 0 | 1 | 0 | 1 | 0 | 1 | 0 | 0 | 84 | E | 659 |
| 0 | 1 | 0 | 1 | 1 | 0 | 0 | 1 | 89 | F | 698 |
| 0 | 1 | 0 | 1 | 1 | 1 | 1 | 1 | 95 | F# | 740 |
| 0 | 1 | 1 | 0 | 0 | 1 | 0 | 0 | 100 | G | 784 |
| 0 | 1 | 1 | 0 | 1 | 0 | 1 | 0 | 106 | G# | 831 |
| 0 | 1 | 1 | 1 | 0 | 0 | 0 | 1 | 113 | A | 880 |
| 0 | 1 | 1 | 1 | 0 | 1 | 1 | 1 | 119 | A# | 932 |
| 0 | 1 | 1 | 1 | 1 | 1 | 1 | 0 | 126 | B | 988 |
| 1 | 0 | 0 | 0 | 0 | 1 | 1 | 0 | 134 | C | 1047 |
| 1 | 0 | 0 | 0 | 1 | 1 | 1 | 0 | 142 | C# | 1109 |
| 1 | 0 | 0 | 1 | 0 | 1 | 1 | 0 | 150 | D | 1175 |
| 1 | 0 | 0 | 1 | 1 | 1 | 1 | 1 | 159 | D# | 1245 |
| 1 | 0 | 1 | 0 | 1 | 0 | 0 | 1 | 169 | E | 1319 |
| 1 | 0 | 1 | 1 | 0 | 0 | 1 | 1 | 179 | F | 1397 |
| 1 | 0 | 1 | 1 | 1 | 1 | 0 | 1 | 189 | F# | 1480 |
| 1 | 1 | 0 | 0 | 1 | 0 | 0 | 1 | 201 | G | 1568 |
| 1 | 1 | 0 | 1 | 0 | 1 | 0 | 1 | 213 | G# | 1661 |
| 1 | 1 | 1 | 0 | 0 | 0 | 0 | 1 | 225 | A | 1760 |
| 1 | 1 | 1 | 0 | 1 | 1 | 1 | 1 | 239 | A# | 1865 |
| 1 | 1 | 1 | 1 | 1 | 1 | 0 | 1 | 253 | B | 1976 |
| 0 | 1 | 0 | 1 | 1 | 0 | 0 | 1 | 89 | DTMF Low | 697 |
| 0 | 1 | 1 | 0 | 0 | 0 | 1 | 1 | 99 | DTMF Low | 770 |
| 0 | 1 | 1 | 0 | 1 | 1 | 0 | 1 | 109 | DTMF Low | 852 |
| 0 | 1 | 1 | 1 | 1 | 0 | 0 | 0 | 120 | DTMF Low | 941 |
| 1 | 0 | 0 | 1 | 1 | 0 | 1 | 1 | 155 | DTMF High | 1209 |
| 1 | 0 | 1 | 0 | 1 | 0 | 1 | 1 | 171 | DTMF High | 1336 |
| 1 | 0 | 1 | 1 | 1 | 1 | 0 | 1 | 189 | DTMF High | 1477 |
| 1 | 1 | 0 | 1 | 0 | 0 | 0 | 1 | 209 | DTMF High | 1633 |

TWL1103 VOICE-BAND AUDIO PROCESSOR (VBAP™)

SLWS108A – JULY 2000 – JANUARY 2001

PRINCIPLES OF OPERATION

DTMF generator operation and interface (continued)

Tones from the DTMF generator block are present at all outputs and are controlled by enabling or disabling the individual output ports. The values that determine the tone frequency are loaded into the tone registers (high and lo) as two separate values.

The values loaded into the tone registers initiate an iterative table look-up function, placing a 6-bit or 7-bit in twos complement value into the the tone registers. There is a 2 dB difference in the resulting output of the two registers, the high-tone register having the greater result.

The resulting range of a tone set into the low register value is +31 {1F}HEX to –32 {20}HEX for a range of six bits and is in twos complement format. The resulting range of a tone set into the high register value is +39 {27}HEX to –40 {D8}HEX in twos-complement format, as well.

The maximum range is six bits having a maximum value of {31}HEX. The value {31} is represented as 011111. Two zeros are added to the leading side of the value and then the value is padded with seven LSB zeros to create a value of 000 1111 1000 0000. Because the maximum full scale value is 000 1111 1000 0000, the resulting output magnitude is $20 \log(\text{input value}/\text{maximum value})$ or $20 \log(3968/16783)$ or –12.31 dB below full scale. This is the result when all gains are set at default.

buzzer logic section

The single-ended output BUZZCON is a PDM signal intended to drive a buzzer through an external driver transistor. The PDM begins as a selected tone, is generated and passed through the receive D/A channel, and is fed back to the transmit channel analog modulator, where a PDM signal is generated and routed to the BUZZCON output.

support section

The clock generator and control circuit uses the master clock input (MCLK) to generate internal clocks to drive internal counters, filters, and converters. Register control data is written into and read back from the VBAP registers via the control interface.

I²C-bus protocols

The VBAP serial interface is designed to be I²C bus-compatible and operates in the slave mode. This interface consists of the following terminals:

SCL: I²C bus serial clock—This input synchronizes the control data transfer from and to the CODEC.

SDA: I²C bus serial address/data input/output—This is a bidirectional terminal that transfers register control addresses and data into and out of the codec. It is an open drain terminal and therefore requires a pullup resistor to V_{CC} (typical 10 k Ω for 100 kHz).

TWL1103 has a fixed device select address of {E2}HEX for write mode and {E3}HEX for read mode.

For normal data transfer, SDA is allowed to change only when SCL is low. Changes when SCL is high are reserved for indicating the start and stop conditions.

Data transfer may be initiated only when the bus is not busy. During data transfer, the data line must remain stable whenever the clock line is at high. Changes in the data line while the clock line is at high are interpreted as a start or stop condition.



PRINCIPLES OF OPERATION

Table 10. I²C Bus Conditions

| CONDITION | STATUS | DESCRIPTION |
|-----------|---------------------|--|
| A | Bus not busy | Both data and clock lines remain at high. |
| B | Start data transfer | A high to low transition of the SDA line while the clock (SCL) is high determines a start condition. All commands must proceed from a start condition. |
| C | Stop data transfer | A low to high transition of the SDA line while the clock (SCL) is high determines a stop condition. All operations must end with a stop condition. |
| D | Data valid | The state of the data line represents valid data when, after a start condition, the data line is stable for the duration of the high period of the clock signal. |

I²C bus protocols

The data on the line must be changed during the low period of the clock signal. There is one clock pulse per bit of data.

Each data transfer is initiated with a start condition and terminated with a stop condition.

When addressed, the VBAP generates an acknowledge after the reception of each byte. The master device (microprocessor) must generate an extra clock pulse that is associated with this acknowledge bit.

The VBAP must pull down the SDA line during the acknowledge clock pulse so that the SDA line is at stable low state during the high period of the acknowledge related clock pulse. Setup and hold times must be taken into account. During read operations, a master must signal an end of data to the slave by not generating an acknowledge bit on the last byte that was clocked out of the slave. In this case, the slave (VBAP) must leave the data line high to enable the master to generate the stop condition.

clock frequencies and sample rates

A fixed PCMSYN rate of 8 kHz determines the sampling rate.

TWL1103 VOICE-BAND AUDIO PROCESSOR (VBAP™)

SLWS108A – JULY 2000 – JANUARY 2001

MECHANICAL DATA

PBS (S-PQFP-G32)

PLASTIC QUAD FLATPACK

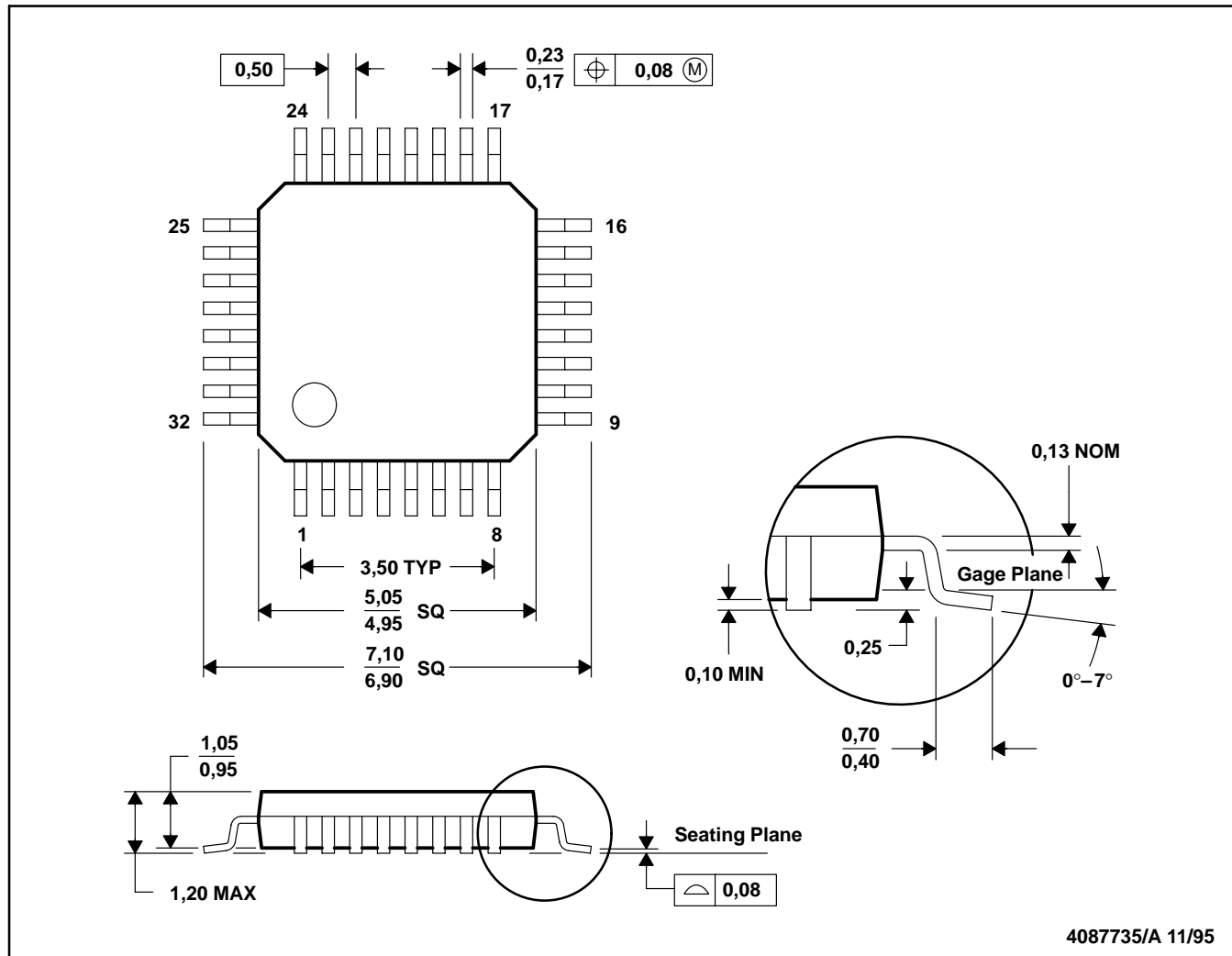

NOTES: A. All linear dimensions are in millimeters.
B. This drawing is subject to change without notice.

MECHANICAL DATA

GQE (S-PBGA-N80)

PLASTIC BALL GRID ARRAY

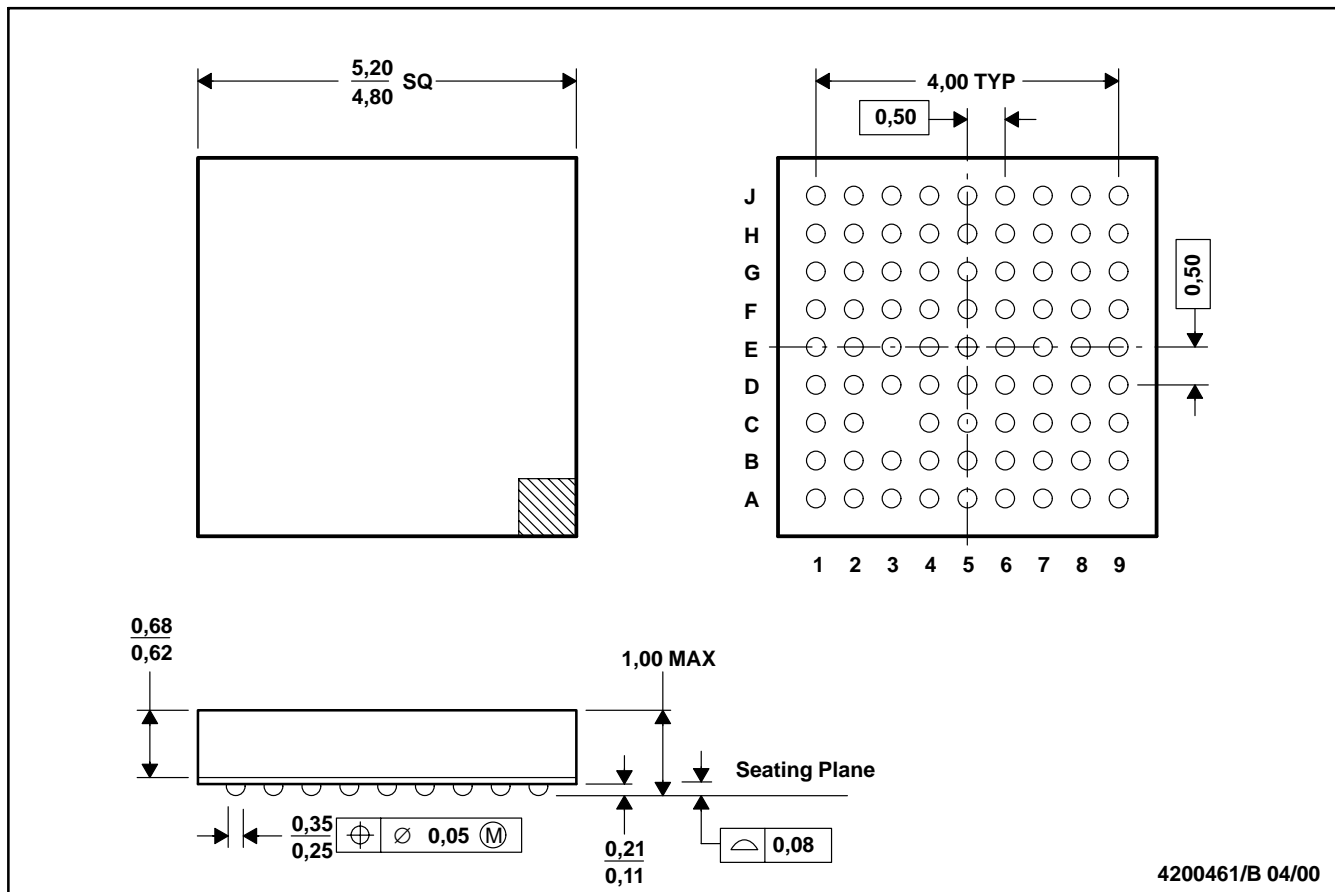

- NOTES: A. All linear dimensions are in millimeters.
 B. This drawing is subject to change without notice.
 C. MicroStar Junior BGA™ configuration

MicroStar Junior BGA is a trademark of Texas Instruments.

IMPORTANT NOTICE

Texas Instruments and its subsidiaries (TI) reserve the right to make changes to their products or to discontinue any product or service without notice, and advise customers to obtain the latest version of relevant information to verify, before placing orders, that information being relied on is current and complete. All products are sold subject to the terms and conditions of sale supplied at the time of order acknowledgment, including those pertaining to warranty, patent infringement, and limitation of liability.

TI warrants performance of its products to the specifications applicable at the time of sale in accordance with TI's standard warranty. Testing and other quality control techniques are utilized to the extent TI deems necessary to support this warranty. Specific testing of all parameters of each device is not necessarily performed, except those mandated by government requirements.

Customers are responsible for their applications using TI components.

In order to minimize risks associated with the customer's applications, adequate design and operating safeguards must be provided by the customer to minimize inherent or procedural hazards.

TI assumes no liability for applications assistance or customer product design. TI does not warrant or represent that any license, either express or implied, is granted under any patent right, copyright, mask work right, or other intellectual property right of TI covering or relating to any combination, machine, or process in which such products or services might be or are used. TI's publication of information regarding any third party's products or services does not constitute TI's approval, license, warranty or endorsement thereof.

Reproduction of information in TI data books or data sheets is permissible only if reproduction is without alteration and is accompanied by all associated warranties, conditions, limitations and notices. Representation or reproduction of this information with alteration voids all warranties provided for an associated TI product or service, is an unfair and deceptive business practice, and TI is not responsible nor liable for any such use.

Resale of TI's products or services with statements different from or beyond the parameters stated by TI for that product or service voids all express and any implied warranties for the associated TI product or service, is an unfair and deceptive business practice, and TI is not responsible nor liable for any such use.

Also see: [Standard Terms and Conditions of Sale for Semiconductor Products](http://www.ti.com/sc/docs/stdterms.htm). www.ti.com/sc/docs/stdterms.htm

Mailing Address:

Texas Instruments
Post Office Box 655303
Dallas, Texas 75265