

CMOS DUAL DIFFERENTIAL COMPARATOR

ADVANCE DATA

- WIDE SINGLE SUPPLY RANGE OR DUAL SUPPLIES 4V TO 10V OR $\pm 2V$ TO $\pm 5V$
- VERY LOW SUPPLY CURRENT : 0.4 mA INDEPENDENT OF SUPPLY VOLTAGE
- EXTREMELY LOW INPUT BIAS CURRENT : 1 pA TYP
- EXTREMELY LOW INPUT OFFSET CURRENT : 1 pA TYP
- LOW INPUT OFFSET VOLTAGE
- INPUT COMMON-MODE VOLTAGE RANGE INCLUDES GND
- LOW OUTPUT SATURATION VOLTAGE 150 mV TYP
- OUTPUT COMPATIBLE WITH TTL.MOS AND CMOS
- BUILT-IN ESD PROTECTION
- HIGH INPUT IMPEDANCE $10^{12} \Omega$ TYP
- FAST REPOSE TIME : 200 NS TYP FOR TTL LEVEL INPUT STEP

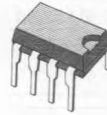

N
DIP14
 (Plastic Package)

J
CERDIP14
 (Cerdip Package)



D
SO14
 (Plastic Micropackage)

(Ordering Information at the end of the datasheet)

PIN CONNECTIONS (top view)

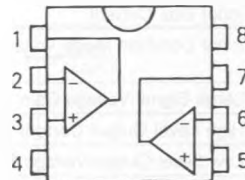

E88TS272-01

DESCRIPTION

These devices consist of two independent precision voltage comparators, designed to operate with single or dual supplies.

These differential comparators use the SGS THOMSON Microelectronics silicon lin MOS process giving them an excellent consumption-speed ratio.

These devices are ideally suited for low consumption applications.

- 1 - Output 1
- 2 - Inverting input 1
- 3 - Non-inverting Input 1
- 4 - V_{CC}^-
- 5 - Non-inverting input 2
- 6 - Inverting input 2
- 7 - Output 2
- 8 - V_{CC}^+

ABSOLUTE MAXIMUM RATINGS

Symbol	Parameter	Value	Unit	
V_{CC}	Supply Voltage (note 1)	12	V	
V_{id}	Differential Input Voltage (note 2)	± 12	V	
V_i	Input Voltage (note 3)	12	V	
V_O	Output Voltage	12	V	
I_O	Output Current	20	mA	
	Duration of Output Short-circuit to GND (note 4)	Unlimited		
T_{oper}	Operating Free-air Temperature	TS372C	0 to 70	°C
		TS372I	- 40 to 105	
		TS372M	- 55 to 125	
T_{stg}	Storage Temperature	- 65 to 150	°C	

- Notes :**
1. All voltage values, except differential voltages are with respect to network ground terminal
 2. Differential voltages are at the non-inverting input terminal with respect to the input terminal.
 3. The magnitude of the input voltage must never exceed the magnitude of the positive supply voltage.
 4. Short circuit from outputs to V_{CC} can cause excessive heating and eventual destruction.

OPERATING CONDITIONS

Symbol	Parameter	Value	Unit
V_{CC}	Supply Voltage Range	4 to 10	V
V_{CC}	Min Supply Voltage (for selected devices)	3	V
V_{CC}	Max Supply Voltage	12	V

ELECTRICAL CHARACTERISTICS ($V_{CC} = +5\text{ V}$, $T = 25\text{ }^\circ\text{C}$)

Symbol	Parameter	Value			Unit
		Min.	Typ.	Max.	
V_{io}	Input Offset Voltage for $V_{IC} = V_{ICR\text{ Min}}$ (note 1)		2	10	mV
i_{io}	Input Offset Current (note 1)		1		pA
i_{ib}	Input Bias Current		1		pA
V_{ICR}	Input Common Mode Voltage Range	0 to V_{CC} - 1.5 V			V
A_{vd}	Large Signal Voltage Gain $V_{CC} = 10\text{ V}$; $R_L > 15\text{ K}\Omega$ at V_{CC}		200		V/mV
I_{oh}	High Level Output Current $V_{id} = 1\text{ V}$; $V_{oh} = +5\text{ V}$		0.1		nA
V_{ol}	Low Level Output Voltage $V_{id} = 1\text{ V}$; $I_{ol} = 4\text{ mA}$		150	400	mV
I_{CC}	Supply Current (4 comparators) $V_{id} = -1\text{ V}$; $R_L = \infty$		0.4	1	mA
I_{ol}	Low Level Output Current $V_{id} = -1\text{ V}$; $V_{OL} = 1.5\text{ V}$	6	16		mA
T_{re}	Response Time $R_L = 5.1\text{ K}\Omega$; $C_L = 15\text{ pF}$ Overdrive 5 mV (note 2)		600		ns
T_{re}	Response Time $R_L = 5.1\text{ K}\Omega$; $C_L = 15\text{ pF}$ TTL Input (note 2)		200		ns

- Notes :**
1. The offset voltage and offset current which are given are the maximum values required to drive the output down to 400 mV or up to 4 V with $R_L = 2.5\text{ K}\Omega$ to V_{CC} .
 2. The response time which is specified is the interval between the input signal and the instant when the output signal crosses 1.4 V.

ORDERING INFORMATION

Part Number	Temperature Range	Package		
		N	D	J
TS372	0 to 70	•	•	
TS372I	- 40 to 105	•	•	
TS372M	- 55 to 125			•

Examples : TS372ID

PACKAGE MECHANICAL DATA

8 PINS - PLASTIC DIP OR CERDIP

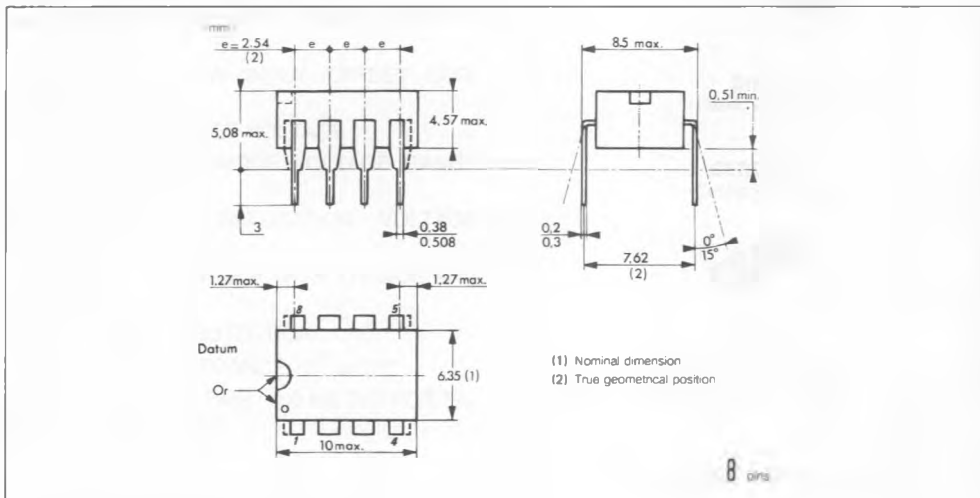

8 PINS - PLASTIC MICROPACKAGE SO

