

- Over Voltage Protection and Lock Out for 5 V, 3.3 V, and 12 V
- Under Voltage Protection and Lock Out for 5 V and 3.3 V
- Fault Protection Output with Open Drain Output Stage
- Open Drain Power Good Output Signal for Power Good Input, 5 V and 3.3 V
- 300 ms Power Good Delay
- 75 ms Delay for 5-V and 3.3-V Short-Circuit Turn On Protection
- 38 ms $\overline{\text{PSON}}$ Control Debounce
- 73 μs Width Noise Deglitches
- Wide Power Supply Voltage Range from 4 V to 15 V

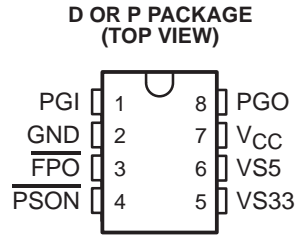

description

The TPS5510 is designed to minimize external components of personal computer switching power supply systems. It provides protection circuits, power good indicator, fault protection output (FPO), and a PSON control.

OVP (Over Voltage Protection) monitors 5 V, 3.3 V, and 12 V (12 V OV detects via V_{CC} terminal). UVP (Under Voltage Protection) monitors 5 V and 3.3 V. When an OV or UV condition is detected, the PGO (power good output) is asserted low and $\overline{\text{FPO}}$ is latched high. $\overline{\text{PSON}}$ from low to high resets the protection latch. UVP function will be enabled 75 ms after $\overline{\text{PSON}}$ is set low and debounced.

Power good feature monitors PGI, 5 V and 3.3 V and issues a power good signal when they are ready.

The TPS5510 is characterised for operation from T_J = -40°C to 125°C junction temperature.

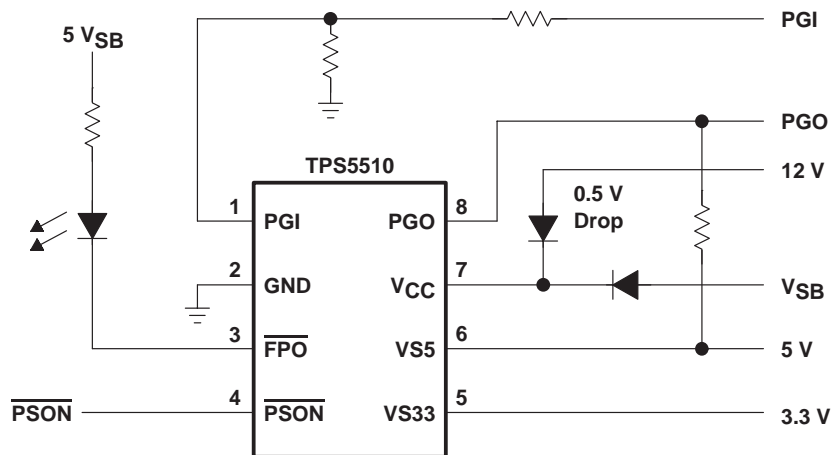

Figure 1. TPS5510 Typical Application



Please be aware that an important notice concerning availability, standard warranty, and use in critical applications of Texas Instruments semiconductor products and disclaimers thereto appears at the end of this data sheet.

TPS5510 3-CHANNEL POWER SUPPLY SUPERVISOR

SLVS168 – JULY 1998

functional block diagram

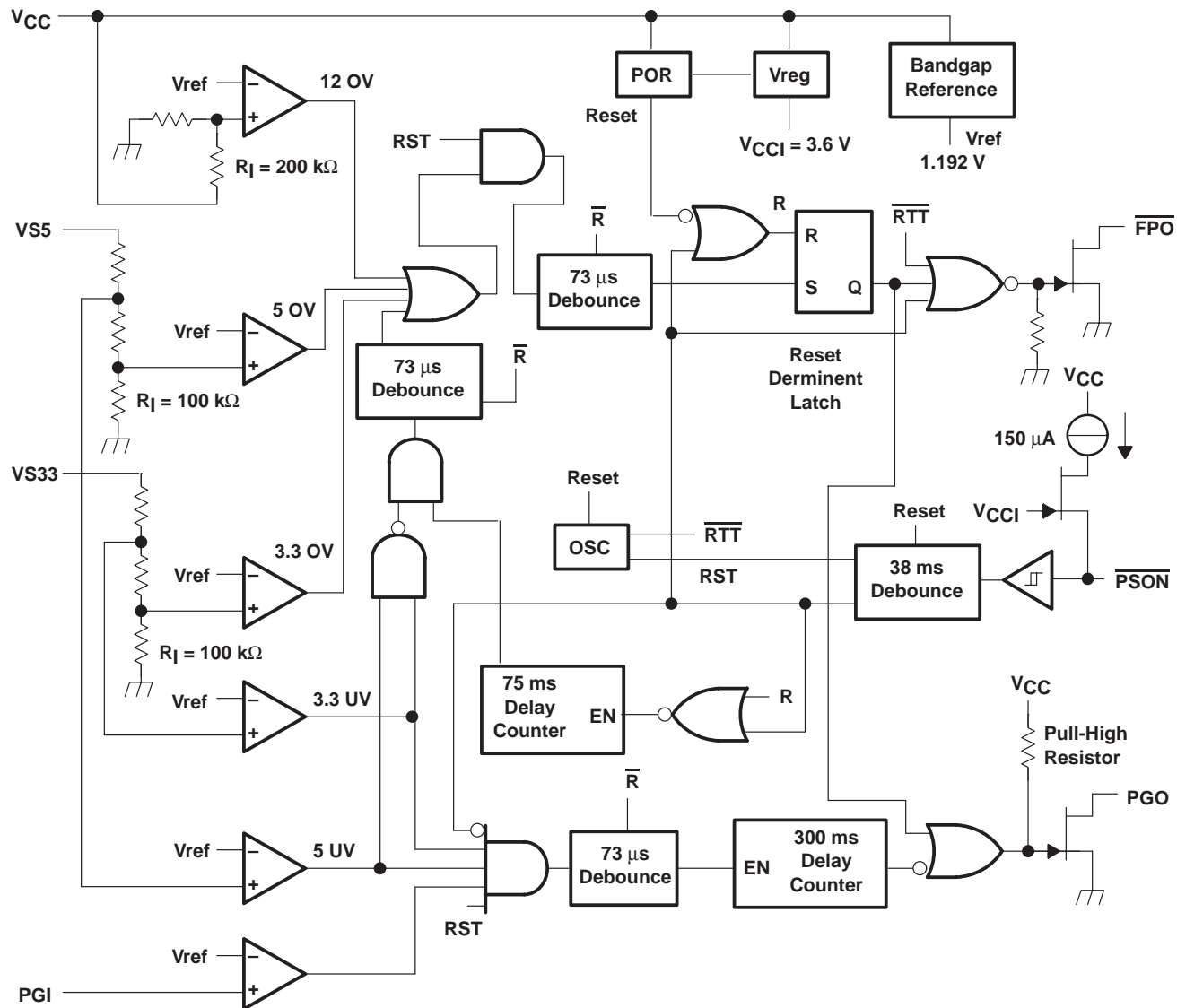

Terminal Functions

TERMINAL NAME	NO.	I/O	DESCRIPTION
VS33	5	I	3.3 V over/under voltage protection input pin
VS5	6	I	5 V over/under voltage protection input pin
GND	2		Ground
$\overline{\text{FPO}}$	3	O	Inverted fault protection output, open drain output stage
PGI	1	I	Power good input signal pin
PGO	8	O	Power good output signal pin, open drain output stage
$\overline{\text{PSON}}$	4	I	ON/OFF control input pin
V _{CC}	7	I	Supply voltage/12 V over voltage protection input pin

DISSIPATION RATING TABLE

PACKAGE	T _A ≤ 25°C POWER RATING	OPERATING FACTOR ABOVE T _A = 25°C	T _A = 125°C POWER RATING
P	1092 mW	8.74 mW/°C	218 mW
D	730 mW	5.84 mW/°C	146 mW

absolute maximum ratings over operating free-air temperature (unless otherwise noted)†

Supply voltage, V _{CC} , (see Note 1)	16 V
Output voltage, V _O ($\overline{\text{FPO}}$)	16 V
Output voltage, V _O (PGO)	8 V
Supply current, I _{CC}	1 mA
Continuous total power dissipation	see Dissipation Rating Table
Operating junction temperature range, T _J	–40°C to 125°C
Storage temperature range, T _{stg}	–65°C to 150°C
Lead temperature, 1,6 mm (1/16 inch) from case for 10 seconds	260°C

† Stresses beyond those listed under “absolute maximum ratings” may cause permanent damage to the device. These are stress ratings only, and functional operation of the device at these or any other conditions beyond those indicated under “recommended operating conditions” is not implied. Exposure to absolute-maximum-rated conditions for extended periods may affect device reliability.

NOTE 1: All voltages are with respect to the device GND terminal.

recommended operating conditions

	TEST CONDITIONS	MIN	TYP	MAX	UNIT
Supply voltage, V _{CC}		4		15	V
Input voltage, V _I	$\overline{\text{PSON}}$, VS5, VS33, PGI			7	V
Output voltage, V _O	$\overline{\text{FPO}}$			15	V
	PGO			7	V
Operating junction temperature, T _J		–40		125	°C
Output sink current, I _{O(sink)}	$\overline{\text{FPO}}$			30	mA
	PGO			10	mA
Supply voltage rising time, t _r	See Note 2	1			ms

NOTE 2: V_{CC} rising and falling slew rate must be less than 14 V/ms.

TPS5510

3-CHANNEL POWER SUPPLY SUPERVISOR

SLVS168 – JULY 1998

electrical characteristics, $V_{CC} = 5\text{ V}$, $T_J = \text{full range}$. (unless otherwise specified)

over voltage protection

PARAMETER		TEST CONDITIONS	MIN	TYP	MAX	UNIT
Over-voltage threshold	VS33		3.9	4.1	4.3	V
	VS5		5.7	6.1	6.5	
	V _{CC}		13.3	13.8	14.3	
I _{LKG}	Leakage current ($\overline{\text{FPO}}$)	V($\overline{\text{FPO}}$) = 5 V			5	μA
V _{OL}	Low level output voltage ($\overline{\text{FPO}}$)	I _{sink} = 10 mA			0.3	V
		I _{sink} = 30 mA			0.7	

PGI and PGO

PARAMETER		TEST CONDITIONS	MIN	TYP	MAX	UNIT
Input threshold voltage (PGI)			1.141	1.192	1.242	V
Under-voltage threshold	VS33		2.71	2.83	2.95	V
	VS5		4.1	4.3	4.47	
Short circuit protection delay time		3.3 V, 5 V	49	75	114	ms
I _{LKG}	Leakage current (PGO)	PGO = 5 V			5	μA
V _{OL}	Low level output voltage (PGO)	Sink current = 10 mA			0.4	V

PSON control

PARAMETER		TEST CONDITIONS	MIN	TYP	MAX	UNIT
Input pull-up current		$\overline{\text{PSON}} = 0\text{ V}$		150		μA
High-level input voltage			2.4			V
Low-level input voltage					1.2	V

total device

PARAMETER		TEST CONDITIONS	MIN	TYP	MAX	UNIT
I _{CC}	Supply current	$\overline{\text{PSON}} = 5\text{ V}$			1	mA

switching characteristics, $V_{CC} = 5\text{ V}$, $T_J = \text{full range}$

PARAMETER		TEST CONDITIONS	MIN	TYP	MAX	UNIT
t _d	Delay time (PGI to PGO)		200	300	450	ms
t _b	De-bounce time ($\overline{\text{PSON}}$)		24	38	57	ms
Noise deglitch time			47	73	110	μs



timing chart

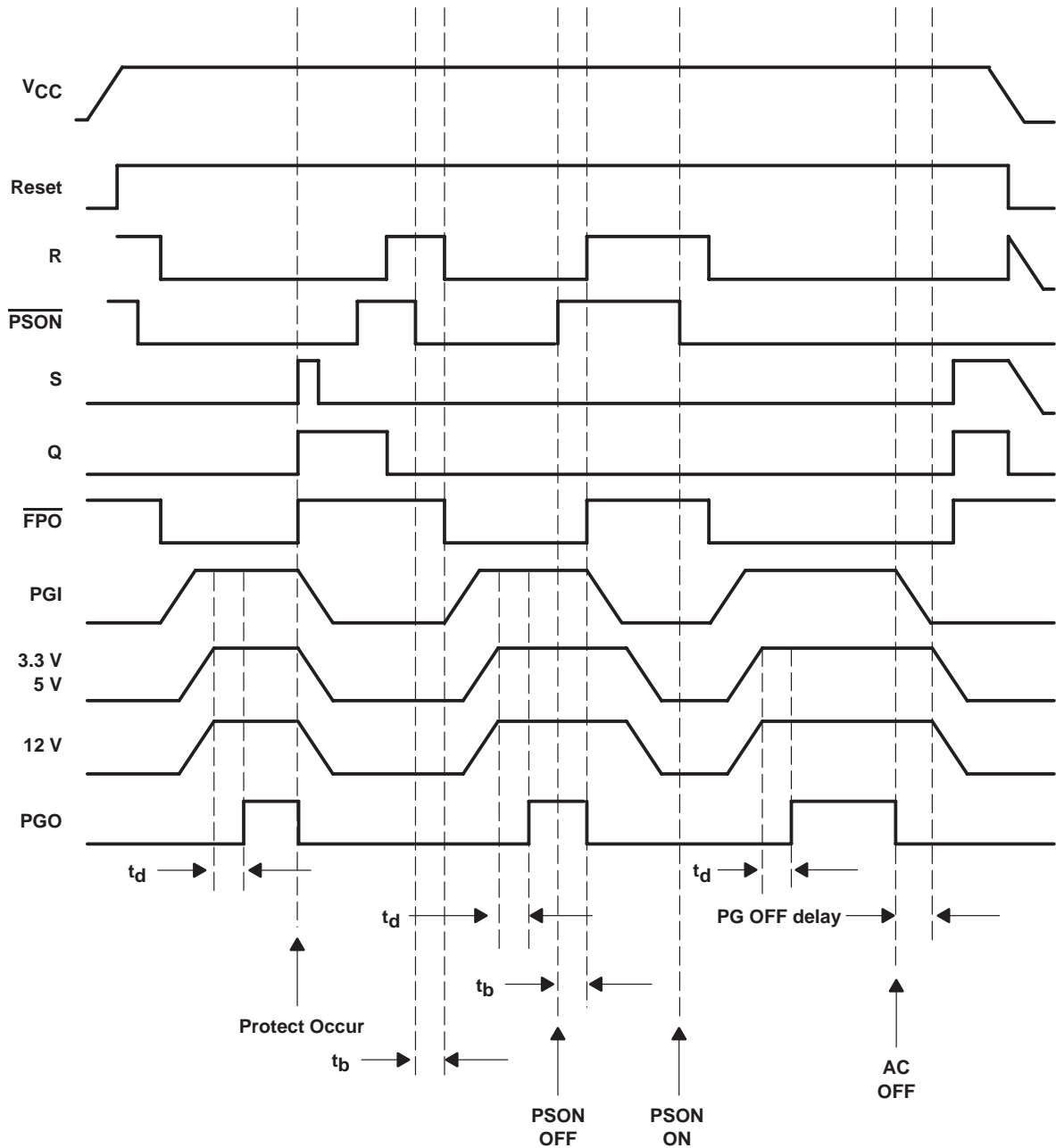

PACKAGING INFORMATION

Orderable Device	Status ⁽¹⁾	Package Type	Package Drawing	Pins	Package Qty	Eco Plan ⁽²⁾	Lead/Ball Finish	MSL Peak Temp ⁽³⁾
TPS5510D	OBSOLETE	SOIC	D	8		TBD	Call TI	Call TI
TPS5510DR	OBSOLETE	SOIC	D	8		TBD	Call TI	Call TI
TPS5510P	OBSOLETE	PDIP	P	8		TBD	Call TI	Call TI

⁽¹⁾ The marketing status values are defined as follows:

ACTIVE: Product device recommended for new designs.

LIFEBUY: TI has announced that the device will be discontinued, and a lifetime-buy period is in effect.

NRND: Not recommended for new designs. Device is in production to support existing customers, but TI does not recommend using this part in a new design.

PREVIEW: Device has been announced but is not in production. Samples may or may not be available.

OBSOLETE: TI has discontinued the production of the device.

⁽²⁾ Eco Plan - The planned eco-friendly classification: Pb-Free (RoHS) or Green (RoHS & no Sb/Br) - please check <http://www.ti.com/productcontent> for the latest availability information and additional product content details.

TBD: The Pb-Free/Green conversion plan has not been defined.

Pb-Free (RoHS): TI's terms "Lead-Free" or "Pb-Free" mean semiconductor products that are compatible with the current RoHS requirements for all 6 substances, including the requirement that lead not exceed 0.1% by weight in homogeneous materials. Where designed to be soldered at high temperatures, TI Pb-Free products are suitable for use in specified lead-free processes.

Green (RoHS & no Sb/Br): TI defines "Green" to mean Pb-Free (RoHS compatible), and free of Bromine (Br) and Antimony (Sb) based flame retardants (Br or Sb do not exceed 0.1% by weight in homogeneous material)

⁽³⁾ MSL, Peak Temp. -- The Moisture Sensitivity Level rating according to the JEDEC industry standard classifications, and peak solder temperature.

Important Information and Disclaimer:The information provided on this page represents TI's knowledge and belief as of the date that it is provided. TI bases its knowledge and belief on information provided by third parties, and makes no representation or warranty as to the accuracy of such information. Efforts are underway to better integrate information from third parties. TI has taken and continues to take reasonable steps to provide representative and accurate information but may not have conducted destructive testing or chemical analysis on incoming materials and chemicals. TI and TI suppliers consider certain information to be proprietary, and thus CAS numbers and other limited information may not be available for release.

In no event shall TI's liability arising out of such information exceed the total purchase price of the TI part(s) at issue in this document sold by TI to Customer on an annual basis.

IMPORTANT NOTICE

Texas Instruments Incorporated and its subsidiaries (TI) reserve the right to make corrections, modifications, enhancements, improvements, and other changes to its products and services at any time and to discontinue any product or service without notice. Customers should obtain the latest relevant information before placing orders and should verify that such information is current and complete. All products are sold subject to TI's terms and conditions of sale supplied at the time of order acknowledgment.

TI warrants performance of its hardware products to the specifications applicable at the time of sale in accordance with TI's standard warranty. Testing and other quality control techniques are used to the extent TI deems necessary to support this warranty. Except where mandated by government requirements, testing of all parameters of each product is not necessarily performed.

TI assumes no liability for applications assistance or customer product design. Customers are responsible for their products and applications using TI components. To minimize the risks associated with customer products and applications, customers should provide adequate design and operating safeguards.

TI does not warrant or represent that any license, either express or implied, is granted under any TI patent right, copyright, mask work right, or other TI intellectual property right relating to any combination, machine, or process in which TI products or services are used. Information published by TI regarding third-party products or services does not constitute a license from TI to use such products or services or a warranty or endorsement thereof. Use of such information may require a license from a third party under the patents or other intellectual property of the third party, or a license from TI under the patents or other intellectual property of TI.

Reproduction of information in TI data books or data sheets is permissible only if reproduction is without alteration and is accompanied by all associated warranties, conditions, limitations, and notices. Reproduction of this information with alteration is an unfair and deceptive business practice. TI is not responsible or liable for such altered documentation.

Resale of TI products or services with statements different from or beyond the parameters stated by TI for that product or service voids all express and any implied warranties for the associated TI product or service and is an unfair and deceptive business practice. TI is not responsible or liable for any such statements.

Following are URLs where you can obtain information on other Texas Instruments products and application solutions:

Products		Applications	
Amplifiers	amplifier.ti.com	Audio	www.ti.com/audio
Data Converters	dataconverter.ti.com	Automotive	www.ti.com/automotive
DSP	dsp.ti.com	Broadband	www.ti.com/broadband
Interface	interface.ti.com	Digital Control	www.ti.com/digitalcontrol
Logic	logic.ti.com	Military	www.ti.com/military
Power Mgmt	power.ti.com	Optical Networking	www.ti.com/opticalnetwork
Microcontrollers	microcontroller.ti.com	Security	www.ti.com/security
		Telephony	www.ti.com/telephony
		Video & Imaging	www.ti.com/video
		Wireless	www.ti.com/wireless

Mailing Address: Texas Instruments
Post Office Box 655303 Dallas, Texas 75265