

TL5812, TL5812I VACUUM FLUORESCENT DISPLAY DRIVERS

SLDS011B – OCTOBER 1985 – REVISED MAY 1993

- Drives up to 20 Lines
- 70-V Output Voltage Swing Capability
- 40-mA Output Source Current Capability
- High-Speed Serially-Shifted Data Input
- CMOS-Compatible Inputs
- Direct Replacement for Sprague UCN5812A

description

The TL5812 and TL5812I are monolithic BIFDET† integrated circuits designed to drive a dot matrix or segmented vacuum fluorescent display (VFD). Each device features a serial data output to cascade additional devices for large display arrays.

A 20-bit data word is serially loaded into the shift register on the low-to-high transition of CLOCK. Parallel data is transferred to the output buffers through a 20-bit D-type latch while LATCH ENABLE is high and is latched when LATCH ENABLE is low. When BLANKING is high, all outputs are low.

The outputs are totem-pole structures formed by npn emitter-follower and double-diffused MOS (DMOS) transistors with output voltage ratings of 70 V and a source-current capability of 40 mA. All inputs are CMOS compatible.

The TL5812 is characterized for operation from 0°C to 70°C. The TL5812I is characterized for operation from -40°C to 85°C.

**N PACKAGE
(TOP VIEW)**

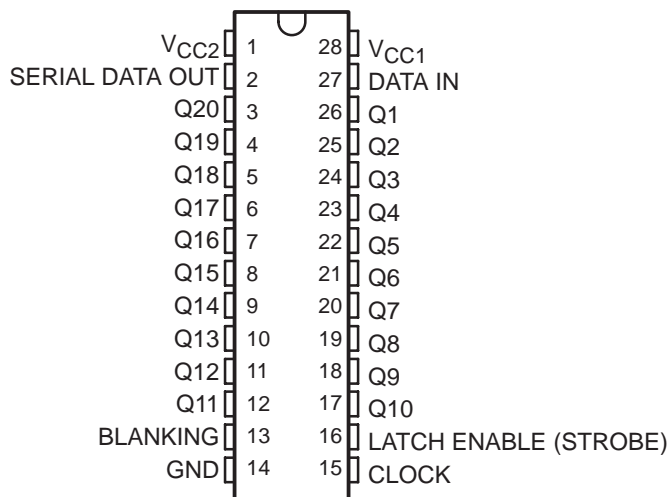

**FN PACKAGE
(TOP VIEW)**

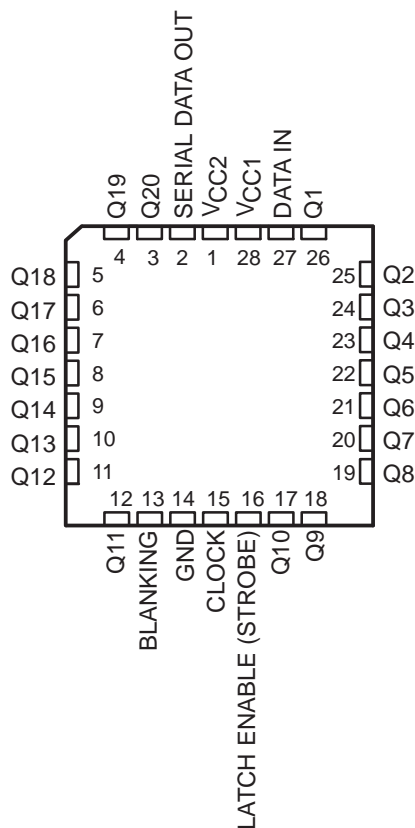

† BIFDET – Bipolar, double-diffused, N-channel and P-channel MOS transistors on same chip. This is a patented process.

PRODUCTION DATA information is current as of publication date. Products conform to specifications per the terms of Texas Instruments standard warranty. Production processing does not necessarily include testing of all parameters.



POST OFFICE BOX 655303 • DALLAS, TEXAS 75265
POST OFFICE BOX 1443 • HOUSTON, TEXAS 77251-1443

Copyright © 1993, Texas Instruments Incorporated

TL5812, TL5812I VACUUM FLUORESCENT DISPLAY DRIVERS

SLDS011B – OCTOBER 1985 – REVISED MAY 1993

logic symbol†

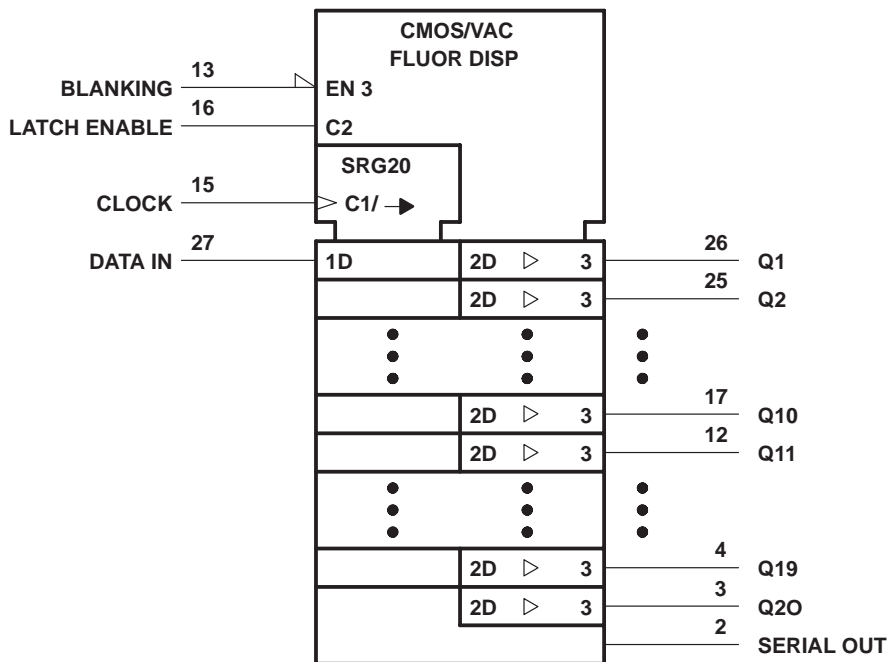

† This symbol is in accordance with ANSI/IEEE Std 91-1984 and IEC Publication 617-12.

logic diagram (positive logic)

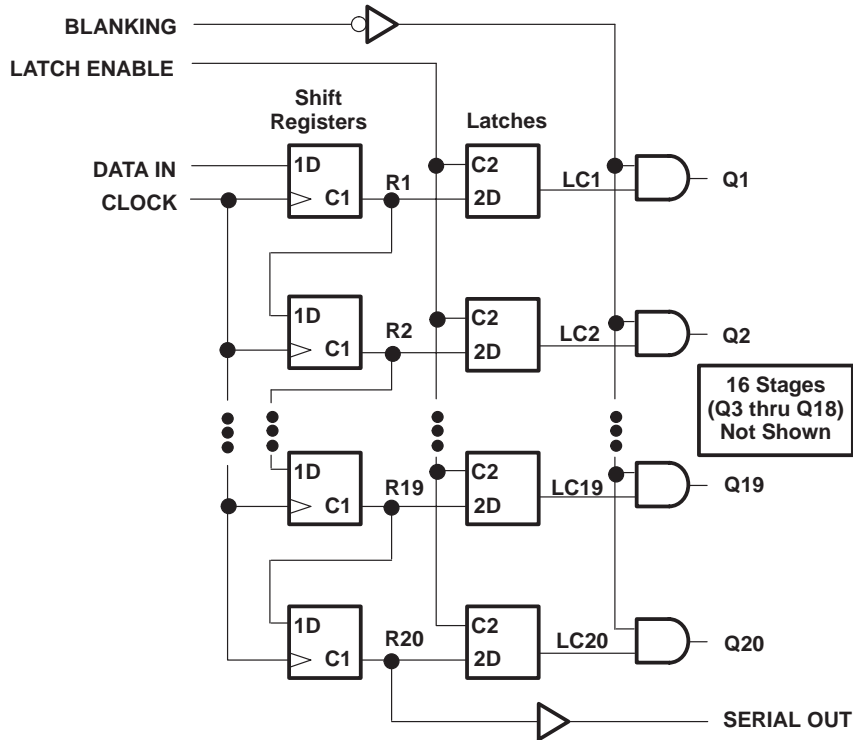

TL5812, TL5812I VACUUM FLUORESCENT DISPLAY DRIVERS

SLDS011B – OCTOBER 1985 – REVISED MAY 1993

FUNCTION TABLE

FUNCTION	CONTROL INPUTS			SHIFT REGISTERS R1 THRU R20	LATCHES LC1 THRU LC20	OUTPUTS	
	CLOCK	LATCH ENABLE	BLANKING			SERIAL	Q1 THRU Q20
Load	↑ No↑	X X	X X	Load and shift† No change	Determined by LATCH ENABLE‡	R20 R20	Determined by BLANKING
Latch	X X	L H	X X	As determined above	Stored data New data	R20 R20	Determined by BLANKING
Blank	X X	X X	H L	As determined above	Determined by LATCH ENABLE‡	R20 R20	All L LC1 thru LC10, respectively

H = high level, L = low level, X = irrelevant, ↑ = low-to-high-level transition.

† R20 takes on the state of R19, R19 takes on the state of R18, ... R2 takes on the state of R1, and R1 takes on the state of the data input.

‡ New data enter the latches while LATCH ENABLE is high. These data are stored while LATCH ENABLE is low.

typical operating sequence

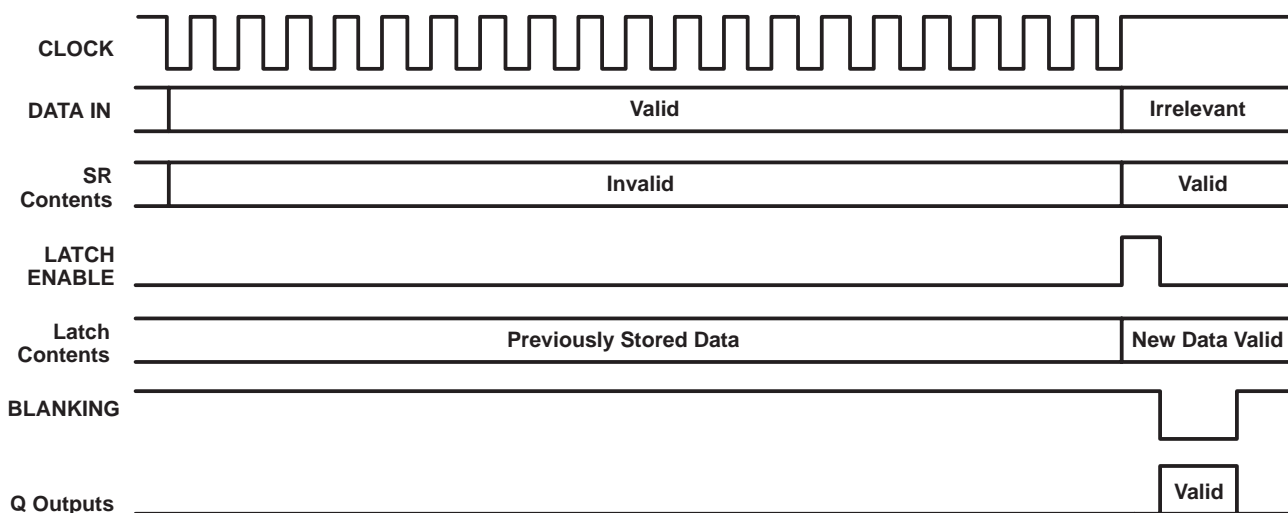

schematics of inputs and outputs

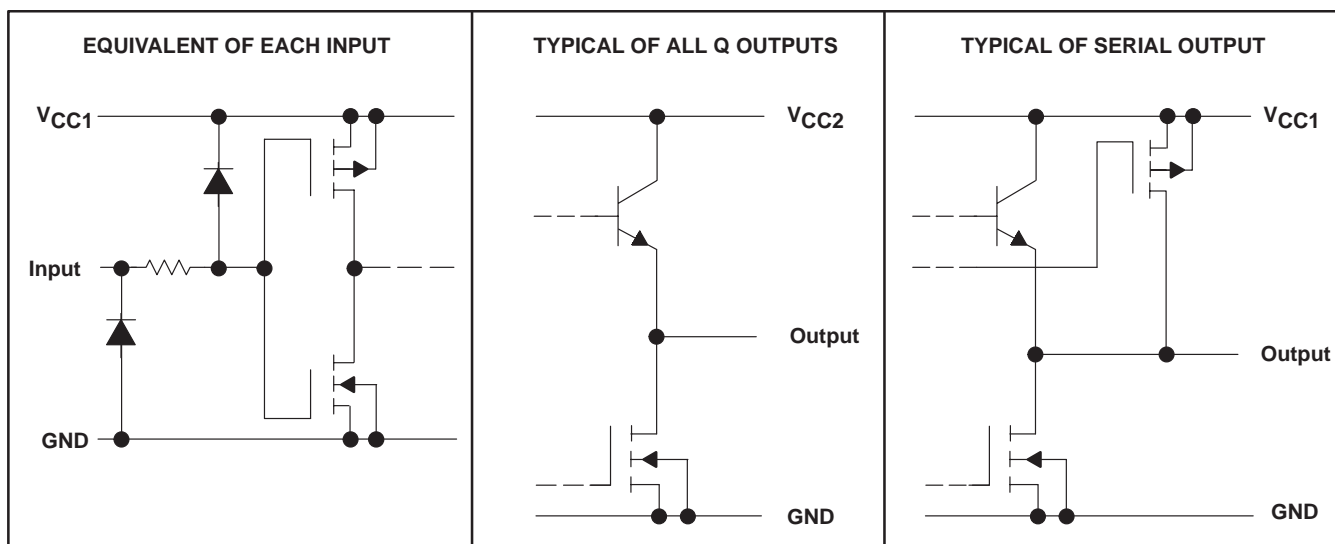

TL5812, TL5812I VACUUM FLUORESCENT DISPLAY DRIVERS

SLDS011B – OCTOBER 1985 – REVISED MAY 1993

absolute maximum ratings over operating free-air temperature range (unless otherwise noted)

Supply voltage, V_{CC1} (see Note 1)	15 V
Supply voltage, V_{CC2}	70 V
Output voltage, V_O	70 V
Input voltage range, V_I	-0.3 V to $V_{CC1} + 0.3$ V
Output current, I_O	-40 mA
Continuous total power dissipation	See Dissipation Rating Table
Operating free-air temperature range: TL5812	0°C to 70°C
TL5812I	-40°C to 85°C
Storage temperature range,	-65°C to 150°C
Case temperature for 10 seconds: FN package	260°C
Lead temperature 1,6 mm (1/16 inch) from case for 10 seconds: N package	260°C

NOTE 1: All voltage values are with respect to GND.

DISSIPATION RATING TABLE

PACKAGE	$T_A \leq 25^\circ\text{C}$ POWER RATING	DERATING FACTOR ABOVE $T_A = 25^\circ\text{C}$	$T_A = 70^\circ\text{C}$ POWER RATING	$T_A = 85^\circ\text{C}$ POWER RATING
FN	1400 mW	11.2 mW/°C	896 mW	728 mW
N	1150 mW	9.2 mW/°C	736 mW	598 mW

recommended operating conditions

	MIN	NOM	MAX	UNIT
Supply voltage, V_{CC1}	4.5		15	V
Supply voltage, V_{CC2}	0		60	V
High-level input voltage, V_{IH}	$V_{CC1} - 1.5$		$V_{CC1} + 0.3$	V
Low-level input voltage, V_{IL}	-0.3†		0.8	V
High-level output current, I_{OH}			-40	mA
Operating free-air temperature, T_A	TL5812		70	°C
	TL5812I		-40	

† The algebraic convention, in which the less positive (more negative) limit is designated as minimum, is used in this data sheet for logic voltage levels.



TL5812, TL5812I

VACUUM FLUORESCENT DISPLAY DRIVERS

SLDS011B – OCTOBER 1985 – REVISED MAY 1993

electrical characteristics over operating free-air temperature range, $V_{DD} = 5\text{ V}$ to 15 V , $V_{BB} = 60\text{ V}$ (unless otherwise noted)

PARAMETER		TEST CONDITIONS	MIN	TYP [‡]	MAX	UNIT
V_{OH}	High-level output	Q outputs		57.5	58.2	V
		SERIAL DATA OUT	$V_{CC1} = 5\text{ V}$, $I_{OH} = -20\text{ }\mu\text{A}$	4.5	4.9	
			$V_{CC1} = 15\text{ V}$, $I_{OH} = -20\text{ }\mu\text{A}$	14.5	14.9	
V_{OL}	Low-level output voltage	Q outputs	$I_{OL} = 1\text{ mA}$, BLANKING at V_{CC1}	0.7	1.5	V
		SERIAL DATA OUT	$V_{CC1} = 5\text{ V}$, $I_{OL} = 20\text{ }\mu\text{A}$	0.06	0.3	
			$V_{CC1} = 15\text{ V}$, $I_{OL} = 20\text{ }\mu\text{A}$	0.03	0.3	
I_{IH}	High-level input current	$V_I = V_{CC1}$		0.3	1	μA
I_{IL}	Low-level input current	$V_I = 0$		-0.3	-1	μA
I_{OL}	Low-level output current (pulldown current)	$V_O = 60\text{ V}$, BLANKING at V_{CC1}	2.5	3.2		μA
$I_{O(off)}$	Off-state output current	$V_O = 0$, BLANKING at V_{CC1}	< -1		-15	μA
I_{CC2}	Supply current from V_{CC2}	Outputs high		3.5	8	mA
		Outputs low		0.02	0.5	
I_{CC1}	Supply current from V_{CC1}	$V_{CC1} = 5\text{ V}$		1.5	3	mA
		$V_{CC1} = 15\text{ V}$		1.7	4	

[‡] All typical characteristics are at $T_A = 25^\circ\text{C}$.

timing requirements over operating free-air temperature range

			MIN	MAX	UNIT
$t_w(\text{CKH})$	Pulse duration, CLOCK high	$V_{CC1} = 5\text{ V}$	500		ns
		$V_{CC1} = 15\text{ V}$	100		
$t_w(\text{LEH})$	Pulse duration, LATCH ENABLE high	$V_{CC1} = 5\text{ V}$	500		ns
		$V_{CC1} = 15\text{ V}$	100		
$t_{su}(\text{D})$	Setup time, DATA IN before CLOCK \uparrow	$V_{CC1} = 5\text{ V}$	150		ns
		$V_{CC1} = 15\text{ V}$	75		
$t_h(\text{D})$	Hold time, DATA IN after CLOCK \uparrow	$V_{CC1} = 5\text{ V}$	150		ns
		$V_{CC1} = 15\text{ V}$	75		
$t_d(\text{CKH-LEH})$	Delay time, CLOCK \uparrow to LATCH ENABLE high	$V_{CC1} = 5\text{ V}$	150		ns
		$V_{CC1} = 15\text{ V}$	75		

switching characteristics, $V_{BB} = 60\text{ V}$, $T_A = 25^\circ\text{C}$

PARAMETER		MIN	TYP	MAX	UNIT
t_{pd}	Propagation delay time, LATCH ENABLE to Q outputs	$V_{CC1} = 5\text{ V}$	2.2		μs
		$V_{CC1} = 15\text{ V}$	0.8		



TL5812, TL5812I VACUUM FLUORESCENT DISPLAY DRIVERS

SLDS011B – OCTOBER 1985 – REVISED MAY 1993

PARAMETER MEASUREMENT INFORMATION

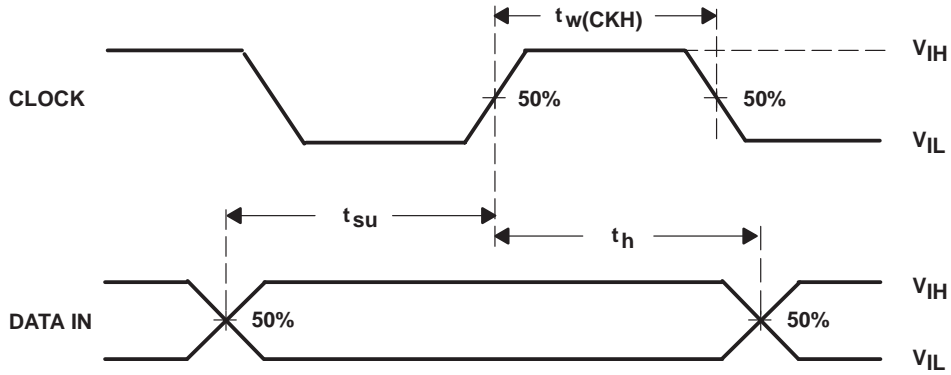

Figure 1. Input Timing

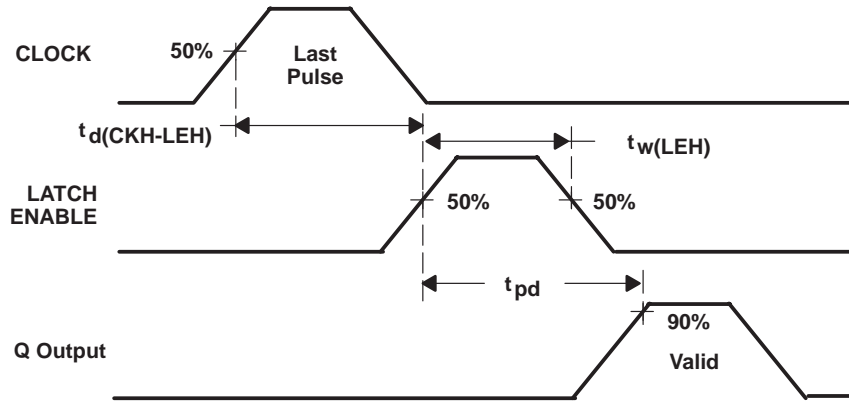

Figure 2. Output Switching Times



POST OFFICE BOX 655303 • DALLAS, TEXAS 75265
POST OFFICE BOX 1443 • HOUSTON, TEXAS 77251-1443

THERMAL INFORMATION

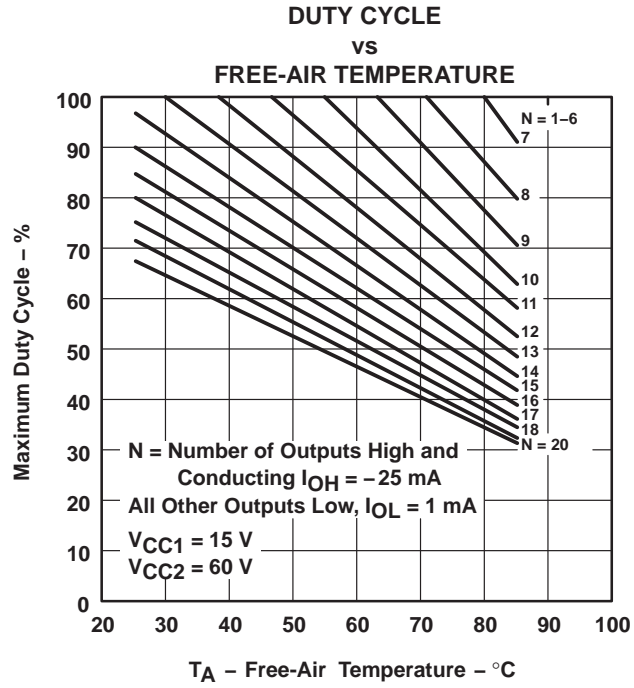

Figure 3

IMPORTANT NOTICE

Texas Instruments Incorporated and its subsidiaries (TI) reserve the right to make corrections, modifications, enhancements, improvements, and other changes to its products and services at any time and to discontinue any product or service without notice. Customers should obtain the latest relevant information before placing orders and should verify that such information is current and complete. All products are sold subject to TI's terms and conditions of sale supplied at the time of order acknowledgment.

TI warrants performance of its hardware products to the specifications applicable at the time of sale in accordance with TI's standard warranty. Testing and other quality control techniques are used to the extent TI deems necessary to support this warranty. Except where mandated by government requirements, testing of all parameters of each product is not necessarily performed.

TI assumes no liability for applications assistance or customer product design. Customers are responsible for their products and applications using TI components. To minimize the risks associated with customer products and applications, customers should provide adequate design and operating safeguards.

TI does not warrant or represent that any license, either express or implied, is granted under any TI patent right, copyright, mask work right, or other TI intellectual property right relating to any combination, machine, or process in which TI products or services are used. Information published by TI regarding third-party products or services does not constitute a license from TI to use such products or services or a warranty or endorsement thereof. Use of such information may require a license from a third party under the patents or other intellectual property of the third party, or a license from TI under the patents or other intellectual property of TI.

Reproduction of TI information in TI data books or data sheets is permissible only if reproduction is without alteration and is accompanied by all associated warranties, conditions, limitations, and notices. Reproduction of this information with alteration is an unfair and deceptive business practice. TI is not responsible or liable for such altered documentation. Information of third parties may be subject to additional restrictions.

Resale of TI products or services with statements different from or beyond the parameters stated by TI for that product or service voids all express and any implied warranties for the associated TI product or service and is an unfair and deceptive business practice. TI is not responsible or liable for any such statements.

TI products are not authorized for use in safety-critical applications (such as life support) where a failure of the TI product would reasonably be expected to cause severe personal injury or death, unless officers of the parties have executed an agreement specifically governing such use. Buyers represent that they have all necessary expertise in the safety and regulatory ramifications of their applications, and acknowledge and agree that they are solely responsible for all legal, regulatory and safety-related requirements concerning their products and any use of TI products in such safety-critical applications, notwithstanding any applications-related information or support that may be provided by TI. Further, Buyers must fully indemnify TI and its representatives against any damages arising out of the use of TI products in such safety-critical applications.

TI products are neither designed nor intended for use in military/aerospace applications or environments unless the TI products are specifically designated by TI as military-grade or "enhanced plastic." Only products designated by TI as military-grade meet military specifications. Buyers acknowledge and agree that any such use of TI products which TI has not designated as military-grade is solely at the Buyer's risk, and that they are solely responsible for compliance with all legal and regulatory requirements in connection with such use.

TI products are neither designed nor intended for use in automotive applications or environments unless the specific TI products are designated by TI as compliant with ISO/TS 16949 requirements. Buyers acknowledge and agree that, if they use any non-designated products in automotive applications, TI will not be responsible for any failure to meet such requirements.

Following are URLs where you can obtain information on other Texas Instruments products and application solutions:

Products

Amplifiers	amplifier.ti.com
Data Converters	dataconverter.ti.com
DSP	dsp.ti.com
Clocks and Timers	www.ti.com/clocks
Interface	interface.ti.com
Logic	logic.ti.com
Power Mgmt	power.ti.com
Microcontrollers	microcontroller.ti.com
RFID	www.ti-rfid.com
RF/IF and ZigBee® Solutions	www.ti.com/lprf

Applications

Audio	www.ti.com/audio
Automotive	www.ti.com/automotive
Broadband	www.ti.com/broadband
Digital Control	www.ti.com/digitalcontrol
Medical	www.ti.com/medical
Military	www.ti.com/military
Optical Networking	www.ti.com/opticalnetwork
Security	www.ti.com/security
Telephony	www.ti.com/telephony
Video & Imaging	www.ti.com/video
Wireless	www.ti.com/wireless

Mailing Address: Texas Instruments, Post Office Box 655303, Dallas, Texas 75265
Copyright © 2008, Texas Instruments Incorporated