

TENTATIVE TOSHIBA BIPOLAR DIGITAL INTEGRATED CIRCUIT SILICON MONOLITHIC

TD7626F, TD7626FN

2.7GHz FREQUENCY SYNTHESIZER FOR SATELLITE TV

TD7626F and TD7626FN are single-chip frequency synthesizer ICs that can be combined with a μ CPU to configure an advanced-function frequency synthesizer system.

TD7626FN comes in a more compact package, pitch 0.65mm.

FEATURES

- High input sensitivity
 $f_{in} = 0.5 \sim 2.7\text{GHz} : -15\text{dBmW} (50\Omega) (\text{Min.})$
- Built-in 1/16 prescaler
- Built-in 5-level AD converter
- Built-in simple comparators $\times 3$
- Simple control bus (I²C bus)
- Four-address selectable by address selector
- Frequency divider ratio settings : 1/512, 1/1024
- Built-in power-on reset circuit
- Small flat package version : TD7626F : SOP16 (1.27mm pitch)
 TD7626FN : SSOP16 (0.65mm pitch)

(Note) These devices are easy to be damaged by high static voltage or electric fields.
 In regards to this, please handle with care.

- Status after power-on reset

Band drive P ₇ ~P ₀	: OFF
Tuning amp	: ON
Charge pump output current	: 50 μ A
Reference frequency divider ratio	: 1/512
Counter data	: All [0]

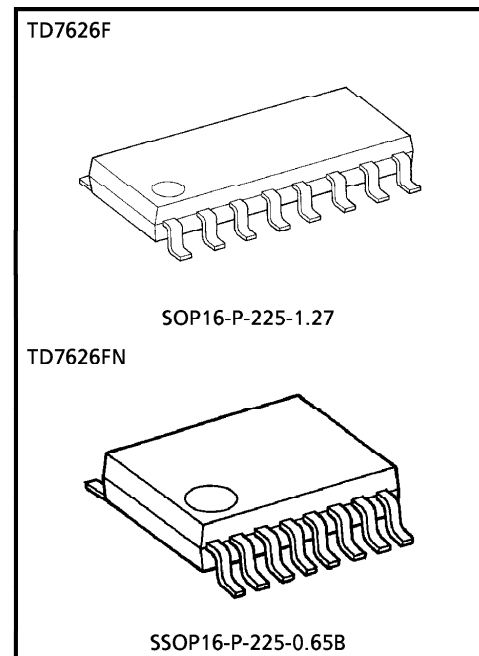

Weight
 SOP16-P-225-1.27 : 0.16g (Typ.)
 SSOP16-P-225-0.65B : 0.07g (Typ.)

961001EBA1

● TOSHIBA is continually working to improve the quality and the reliability of its products. Nevertheless, semiconductor devices in general can malfunction or fail due to their inherent electrical sensitivity and vulnerability to physical stress. It is the responsibility of the buyer, when utilizing TOSHIBA products, to observe standards of safety, and to avoid situations in which a malfunction or failure of a TOSHIBA product could cause loss of human life, bodily injury or damage to property. In developing your designs, please ensure that TOSHIBA products are used within specified operating ranges as set forth in the most recent products specifications. Also, please keep in mind the precautions and conditions set forth in the TOSHIBA Semiconductor Reliability Handbook.

● The products described in this document are subject to foreign exchange and foreign trade control laws.

● The information contained herein is presented only as a guide for the applications of our products. No responsibility is assumed by TOSHIBA CORPORATION for any infringements of intellectual property or other rights of the third parties which may result from its use. No license is granted by implication or otherwise under any intellectual property or other rights of TOSHIBA CORPORATION or others.

● The information contained herein is subject to change without notice.

BLOCK DIAGRAM

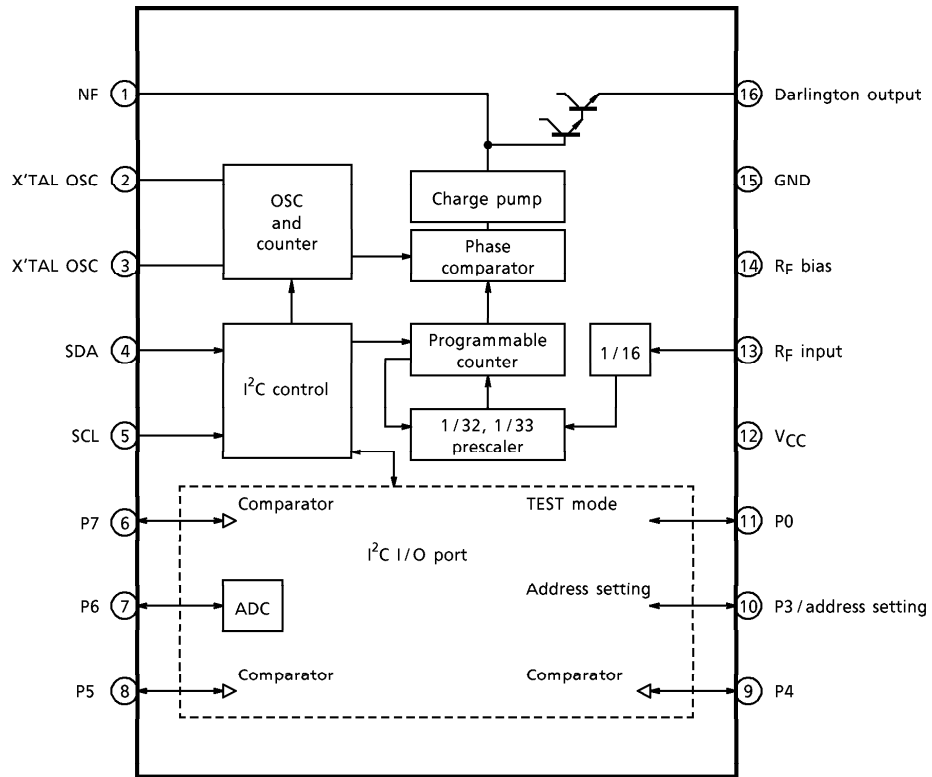

TERMINAL FUNCTIONS

PIN No.	PIN NAME	FUNCTION	INTERFACE CIRCUIT
1	NF	Compares the phase of the input R_F signal against the frequency data and feeds back its difference output from the current pump.	
16	Charge pump output		
2	X'tal OSC _{in}	Crystal oscillator pins to generate the reference signal for the phase comparator. Consist of the inverter amp.	
3	X'tal OSC _{out}		
4	SDA	Normally used as input/output pins for the I ² C bus serial data. In TEST mode, used as the input pin for the signal to be compared by the phase comparator.	
5	SCL	Normally used as the I ² C bus serial clock input. In TEST mode, used to input the reference signal of the phase comparator.	
6	P7	Output can be controlled by setting the band switch data. The circuit configuration is open collector output. Each pin has a built-in comparator. The status of the comparator can be checked in READ mode. In TEST mode, P7 is a counter output which allows counter operation to be checked.	
8	P5		
9	P4		

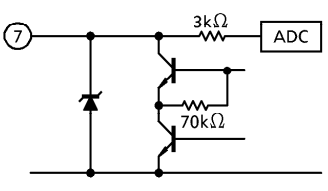
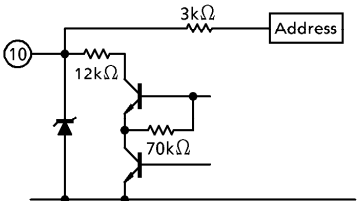
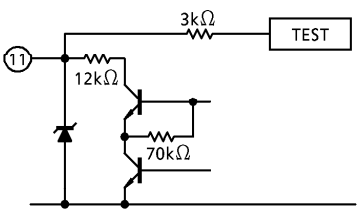
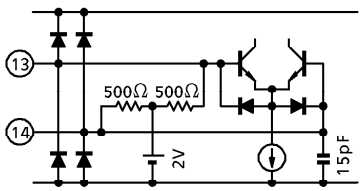
PIN No.	PIN NAME	FUNCTION	INTERFACE CIRCUIT
7	P6	<p>Output can be controlled by setting the band switch data.</p> <p>The circuit configuration is open collector output.</p> <p>An A/D converter is built in. In READ mode, five levels of applied voltage can be read.</p> <p>In TEST mode, outputs the reference signal derived by dividing the crystal OSC signal by the set divider ratio. This allows operation to be checked.</p>	
10	P3	<p>Basically used as the address setting pin. The sub-address can be changed by applied voltage.</p> <p>Can be used as a band switch as well, but incorporates resistance (12kΩ) for limiting current.</p>	
11	P0	<p>Output can be controlled by setting the band switch data. Incorporates resistance (12kΩ) for limiting current. (Can also be used for setting the prescaler in TEST mode.)</p> <p>(Open collector output)</p>	
12	VCC	Power supply pin	—
13 14	R _F input R _F bias	<p>Prescaler input pins.</p> <p>The circuit configuration is differential input.</p> <p>Differential reference bias pin 14 has a built-in 15pF capacitor.</p>	
15	GND	Ground pin	—

MAXIMUM RATINGS (Ta = 25°C)

CHARACTERISTICS	SYMBOL	RATING	UNIT
Supply Voltage 1	V _{CC1}	6.0	V
Power Dissipation	P _D	(Note 1)	mW
Operating Temperature	T _{opr}	- 20~85	°C
Storage Temperature	T _{stg}	- 55~150	°C

(Note 1) F-type : 540mW, FN-type : 560mW

(Note 2) When using the device at temperatures higher than 25°C, maximum power dissipation decreases for every 1°C as follows : 4.3mW with F-type : 4.5mW with FN-type.

(Note 3) Do not set the port pins (Pins 6, 7, 8, 9, 10, and 11) at or lower than the level of the GND pin.

(Note 4) These devices are easy to be damaged by high static voltage or electric fields. In regards to this, please handle with care.

RECOMMENDED SUPPLY VOLTAGE

PIN No.	PIN NAME	MIN.	TYP.	MAX.	UNIT
12	V _{CC}	4.5	5.0	5.5	V

ELECTRICAL CHARACTERISTICS (Unless otherwise stated, $V_{CC} = 5V$, $T_a = 25^\circ C$)

AC CHARACTERISTICS

CHARACTERISTIC	SYMBOL	TEST CIR-CUIT	TEST CONDITION	MIN.	TYP.	MAX.	UNIT
Supply Current	I_{CC1}	1	Band switch : OFF OS : [1]	20	35	52	mA
Prescaler Input Sensitivity	V_{in}	2	$f = 500 \sim 2700 \text{MHz}$	- 15	—	+ 3	dBmW
Logic Input High Voltage	V_{IH}	3	Logic pins (SDA, SCL) In the test circuit, transfer P5 data and determine reception from the lighting of the LED lamp. Measure the output using a logic analyzer.	3.0	—	—	V
Logic Input Low Voltage	V_{IL}			—	—	0.8	
Logic Output High Voltage	V_{OH}			3.8	—	—	
Logic Output Low Voltage	V_{OL}			—	—	0.5	
Logic Input High Current	I_{IH}	3	Apply 5V to input pin.	—	—	10	μA
Logic Input Low Current	I_{OL}		Apply 0V to input pin.	—	—	- 20	
External OSC Input Amplitude	OSC_{in}	3	OSC_{in} (Pin 2)	150	—	—	mV _{p-p}
OSC Operating Frequency	OSC_{fin}	3	Pins 2, 3	3.0	4.0	4.5	MHz
Crystal Negative Resistance	X_{tR}	3	TEST mode, frequency divided crystal signal output, P6 monitor	—	1.5	—	k Ω
Output Port Flow Current	IP_{in}	3	P4, P5, P6, P7	5	—	—	mA
Output Port Leakage Current	IP_{lk}	3	Apply 12V as pull-up voltage.	—	—	10	μA
Output Port Built-In Resistance	R_{port}	—	P0 and P3	—	12	—	k Ω
Output Port MAX Voltage	V_{port}	—	P0, P3, P4, P5, P6, P7	—	—	13.2	V
A / D Converter Input Voltage	V_{ADC}	—	P6	0.0	—	13.2	V
Comparator Pin Input Voltage	V_{CMP}	3	P4, P5, and P7	0.0	—	13.2	V
Comparator High Voltage	V_{HCMP}	3	P4, P5, and P7	2.0	—	13.2	V
Comparator Low Voltage	V_{LCMP}	3	P4, P5, and P7	0.0	—	0.8	V
Charge Pump Output Current	I_{chg0}	—	CP : [0]	—	50	—	μA
			CP : [1]	—	170	—	

DATA FORMAT

a) WRITE mode

BYTE		MSB							LSB	
1	ADDRESS Byte	1	1	0	0	0	MA1	MA0	R / W = 0	ACK
2	DIVIDER Byte①	0	2 ¹⁴	2 ¹³	2 ¹²	2 ¹¹	2 ¹⁰	2 ⁹	2 ⁸	ACK
3	DIVIDER Byte②	2 ⁷	2 ⁶	2 ⁵	2 ⁴	2 ³	2 ²	2 ¹	2 ⁰	ACKⓁ
4	CONTROL Byte	1	CP	T ₁	T ₀	TS2	TS1	TS0	OS	ACK
5	BAND SW Byte	P7	P6	P5	P4	P3	X	X	P0	ACKⓁ

- Ⓛ : DATA LATCH
- X : DON'T Care
- ACK : Acknowledgment

b) READ mode

BYTE		MSB							LSB	
1	ADDRESS Byte	1	1	0	0	0	MA1	MA0	R / W = 1	ACK
2	STATUS Byte	0	FL	IP7	IP5	IP4	A ₂	A ₁	A ₀	ACK

ACK : Acknowledgment

DATA DETAILS

- MA1, MA0 : Programmable address bits
(Indicate applied voltage of pin 10 and corresponding address setting.)

ADDRESS PIN APPLIED VOLTAGE	MA1	MA0
0~0.2×V _{CC}	0	0
0.3×V _{CC} ~0.7×V _{CC}	1	0
0~V _{CC}	0	1
0.8×V _{CC} ~V _{CC}	1	1

- CP : Charge pump current setting
 『 0 』 : 50μA (Typ.)
 『 1 』 : 170μA (Typ.)
- T₁ : Test mode switching
 『 0 』 : NORMAL mode
 『 1 』 : TEST mode
- T₀ : Charge pump control setting
 『 0 』 : Charge pump ON
 『 1 』 : Charge pump OFF

- TS2, TS1, TS0 : TEST mode settings

CHARACTERISTIC	T ₁	TS2	TS1	TS0	FREQUENCY DIVIDER RATIO	REMARKS	
Normal State	0	X	X	0	1/1024	—	
Normal State	0	X	X	1	1/512	—	
Charge Pump	Sink	1	1	0	0	1/1024	FL=0 : Charge pump output sink side only on
	Source	1	1	0	1	1/512	FL=1 : Charge pump output source side only on
Output Port OFF	1	1	1	0	1/1024	P7~P4 = OFF	
Phase Comparator Test	1	1	1	1	1/512	SDA : Input of signal to be compared SCL : Reference signal input	
Crystal Divider Counter Output	1	0	X	0	1/1024	P6 : Crystal divider output P7 : Counter output (1/16×32×count data) P0 : Prescaler settings… 『0』 : ON 『1』 : OFF P7~P4 = OFF	
	1	0	X	1	1/512		

X : DON'T Care

- OS : Tuning amp control settings
『0』 : Tuning on (Normal state)
『1』 : Tuning off (Fixes charge pump output at 0.0~0.2V)
- FL : Lock detect flag
『0』 : Unlocked
『1』 : Locked
- IP7, IP5, IP4 : Comparator output (P7, P5, P4)
『0』 : Applied voltage 0.0~0.8V
『1』 : Applied voltage 2.0~13.2V
- A2, A1, A0 : 5-level A/D converter (P6)

ADC PIN APPLIED VOLTAGE	A ₂	A ₁	A ₀
0.60×V _{CC} ~13.2V	1	0	0
0.45×V _{CC} ~0.60×V _{CC}	0	1	1
0.30×V _{CC} ~0.45×V _{CC}	0	1	0
0.15×V _{CC} ~0.30×V _{CC}	0	0	1
0~0.15×V _{CC}	0	0	0

I²C BUS CONTROLLED FORMAT SUMMARY

Bus controlled format of TD7626F, TD7626FN are based on I²C Bus Control format of Philips.

Data transfer format

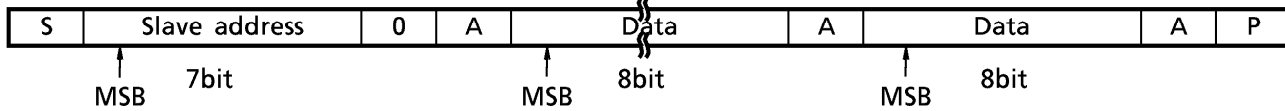

S : Start conditions
 P : Stop conditions
 A : Acknowledge

(1) Start condition and stop condition

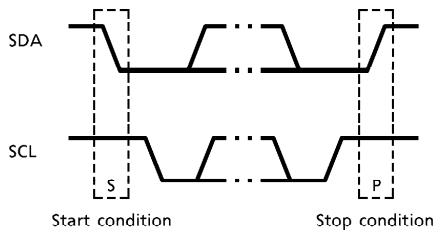

(2) Bit transfer

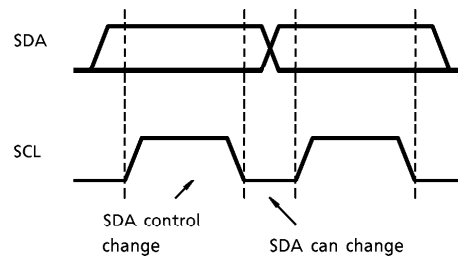

(3) Acknowledgement

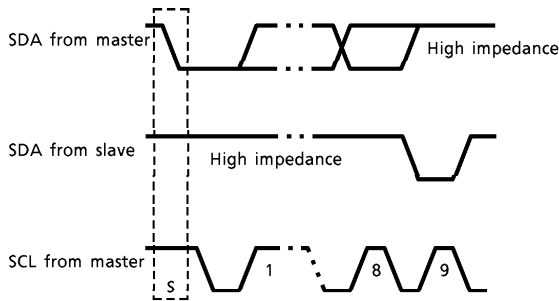

(4) Slave addresses

A ₆	A ₅	A ₄	A ₃	A ₂	A ₁	A ₀	R/ \bar{W}
1	1	0	0	0	X	X	0

Purchase of TOSHIBA I²C components conveys a license under the Philips I²C Patent Rights to use these components in an I²C system, provided that the system conforms to the I²C Standard Specification as defined by Philips.

TEST CIRCUIT 1

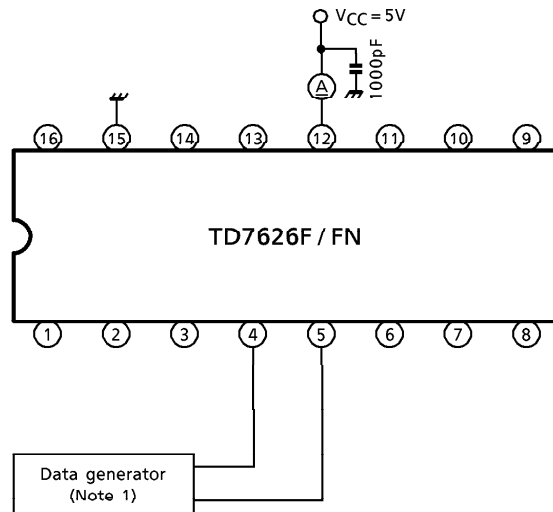

(Note 1) Band switch...OFF, tuning amp...OFF

TEST CIRCUIT 2

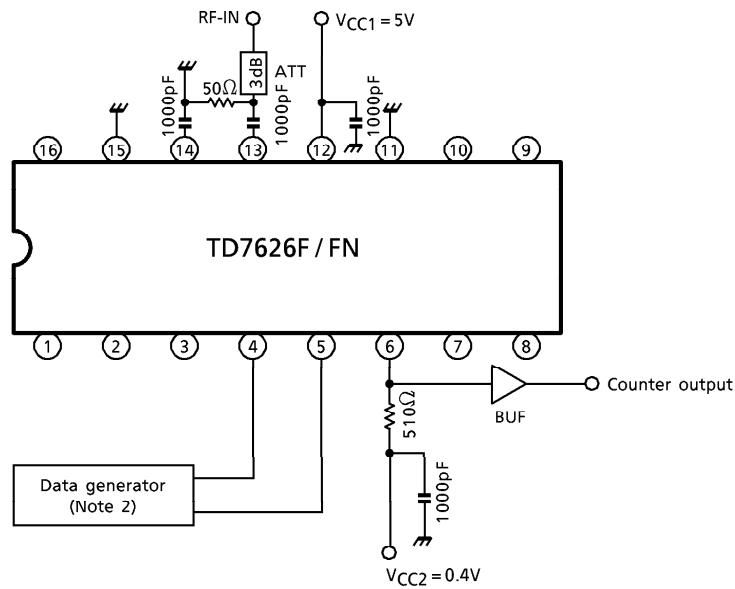

(Note 2) See TEST mode settings (Counter output)

TEST CIRCUIT 3

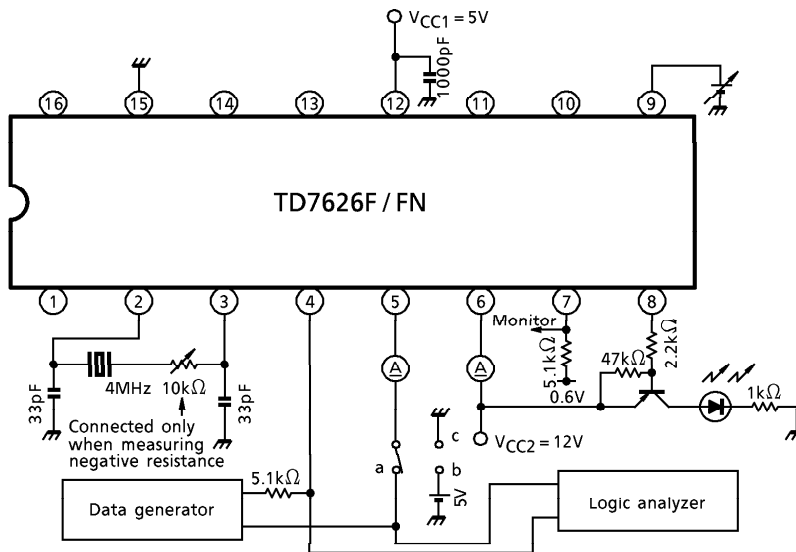

TEST CIRCUIT 4

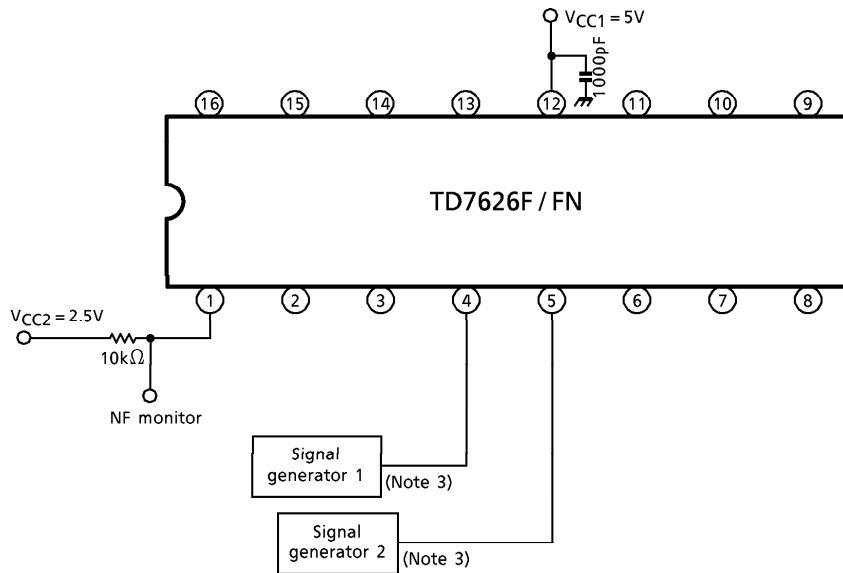

(Note 3) Phase comparator input level

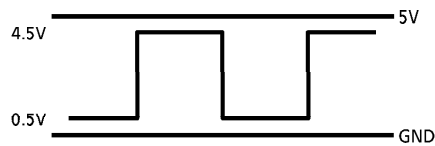

EXAMPLE OF FREQUENCY SYNTHESIZER APPLICATION CIRCUIT

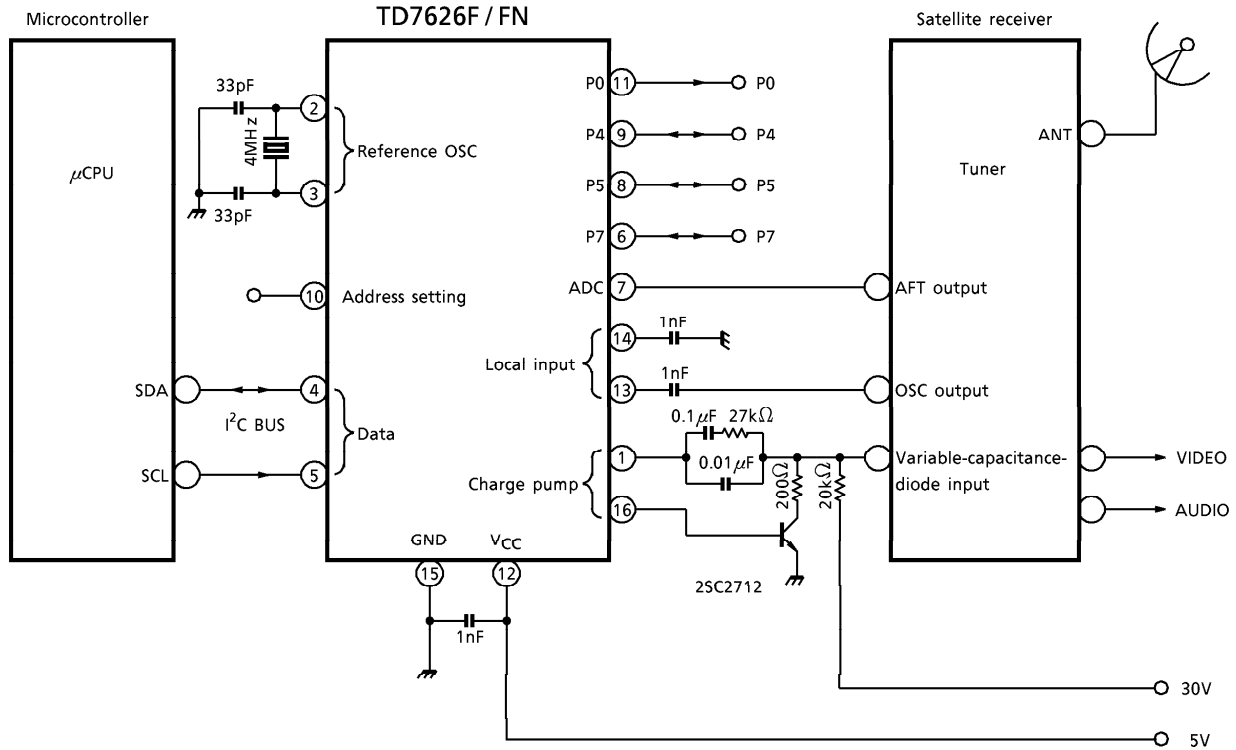

OUTLINE DRAWING
SOP16-P-225-1.27

Unit : mm

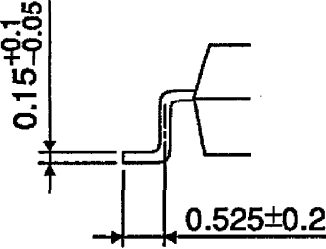
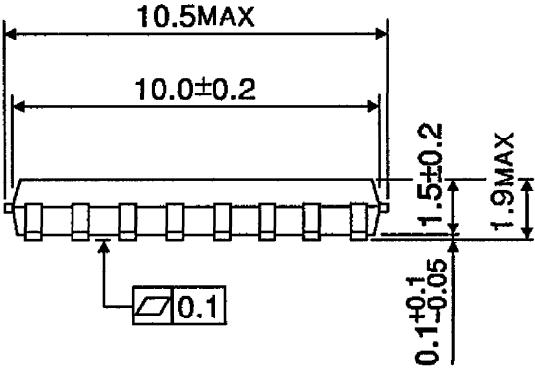
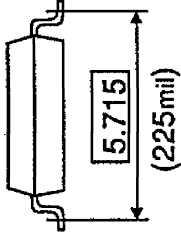
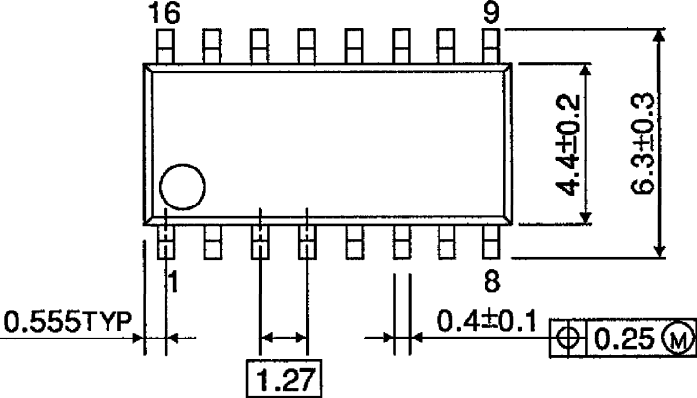

Weight : 0.16g (Typ.)

OUTLINE DRAWING

SSOP16-P-225-0.65B

Unit : mm

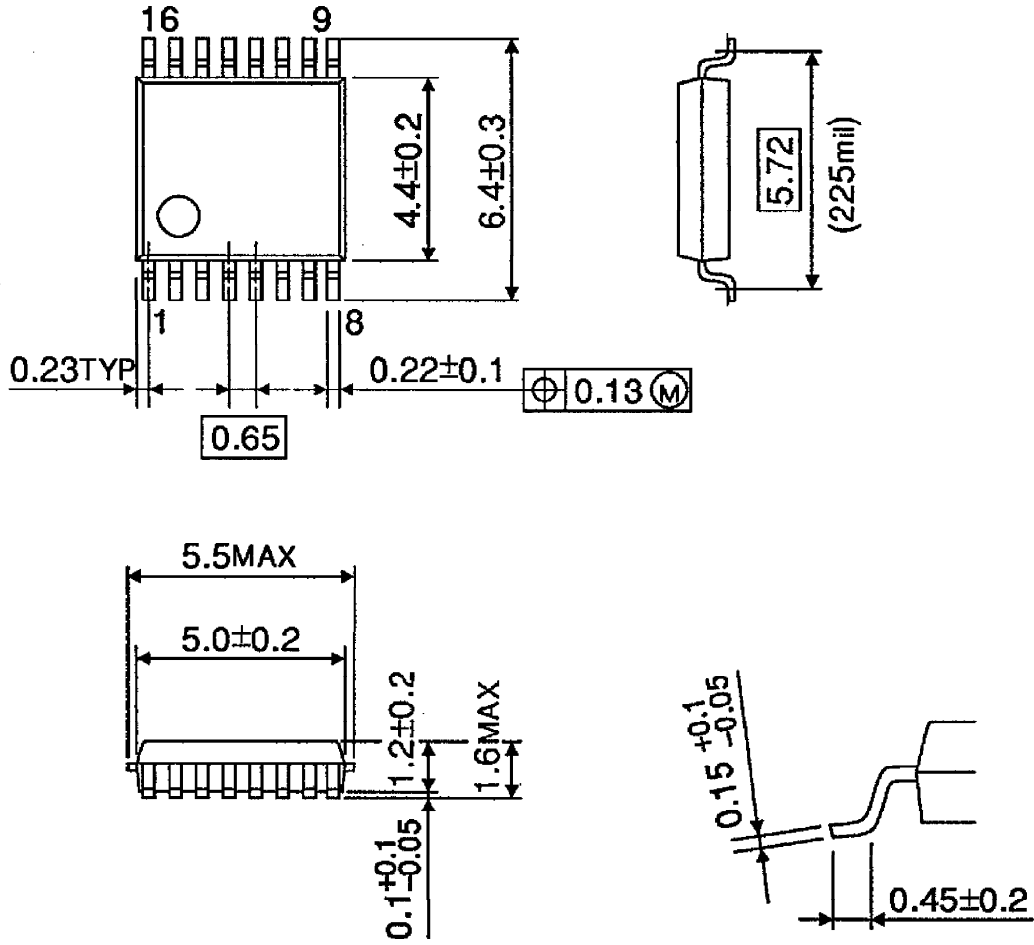

Weight : 0.07g (Typ.)