

QUARTZ PLL MOTOR CONTROL

The TC9242P, TC9242F are CMOS LSIs developed for controlling the motor speed.
Since an 8bit D/A converter system has been employed for each of the speed control system (AFC) and the phase control system (APC).
Offers improved linearity.
With frequency division ratios of 1/3, 1/4 and 1/5 the standard divider is ideal for laser scanner motors.

FEATURES

- Crystal can be used up to 20MHz, and crystal reference dividing frequency is selectable from three positions of 1/3, 1/4 and 1/5.
- Lock range can be selected from two positions of 1/20 and 1/27.
- External oscillator makes possible fine adjustment of speed.
- Lock detection output and reverse rotation signal output are provided.
- Package is DIP16PIN and SOP16PIN.

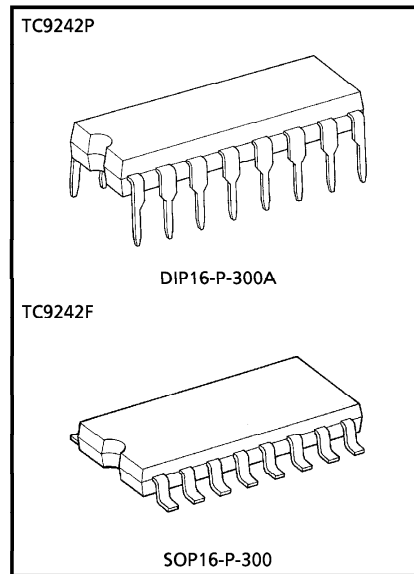

Weight DIP16-P-300A : 1.00g (Typ.)
SOP16-P-300 : 0.16g (Typ.)

PIN CONNECTIONS (TOP VIEW)

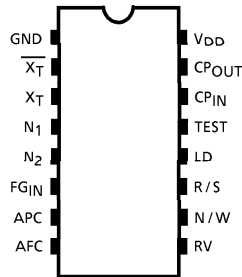

© The information contained herein is presented only as a guide for the applications of our products. No responsibility is assumed by TOSHIBA CORPORATION for any infringements of intellectual property or other rights of the third parties which may result from its use. No license is granted by implication or otherwise under any intellectual property or other rights of TOSHIBA CORPORATION or others.

© These TOSHIBA products are intended for use in general commercial applications (office equipment, communication equipment, measuring equipment, domestic appliances, etc.), please make sure that you consult with us before you use these TOSHIBA products in equipment which requires extraordinarily high quality and/or reliability, and in equipment which may involve life threatening or critical application, including but not limited to such uses as atomic energy control, airplane or spaceship instrumentation, traffic signals, medical instrumentation, combustion control, all types of safety devices, etc. TOSHIBA cannot accept and hereby disclaims liability for any damage which may occur in case the TOSHIBA products are used in such equipment or applications without prior consultation with TOSHIBA.

BLOCK DIAGRAM

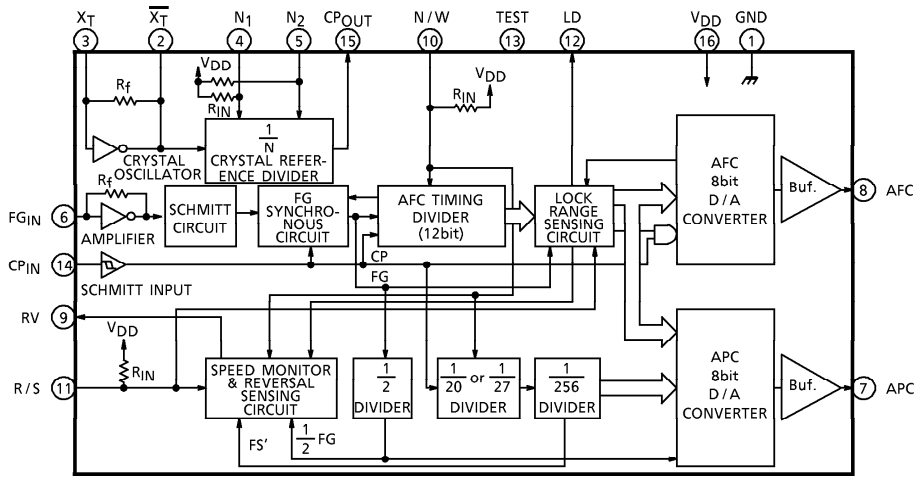

FUNCTIONAL EXPLANATION OF EACH TERMINAL

PIN No.	SYMBOL	PIN NAME	FUNCTIONAL & OPERATION EXPLANATION	REMARKS
16	V _{DD}	Power Terminal	V _{DD} = 5V ± 0.5V is applied.	—
1	GND	Ground Terminal	Ground	—
2	X _T ⁻	Crystal Oscillation Terminal	Crystal oscillator is connected.	With a built-in feedback resistor.
3	X _T			
4	N ₁	Reference Divided Frequency Switching Terminal	Switching of divided frequency from the crystal reference frequency divider into 1/3, 1/4 and 1/5 is possible.	With a built-in pull-up resistor.
5	N ₂			
6	FG _{IN}	FG Pulse Input Terminal	Input terminal for pulse showing motor speed.	With a built-in amplifier.
7	APC	APC Output Terminal	Output terminal for motor phase control system. Output of 8bit D/A converter.	With a built-in buffer.
8	AFC	AFC Output Terminal	Output terminal for motor speed control system. Output of 8bit D/A converter.	With a built-in buffer.
9	RV	Reverse Signal Output Terminal	Terminal for motor reverse signal output.	CMOS OUTPUT
10	N/W	Lock range Switching Terminal	Terminal for switching motor speed. L = 1/27, H or NC = 1/20.	With a built-in pull-up resistor.
11	R/S	RUN/STOP Input Terminal	Motor RUN/STOP signal input terminal L = RUN, H or NC = STOP	With a built-in pull-up resistor.
12	LD	Lock Detecting Terminal	This terminal becomes "H" when the motor speed is within the lock range and otherwise "L".	CMOS OUTPUT
14	CP _{IN}	Reference Frequency Input Terminal	Normally connected to CPOUT. For external fine adjustment input from an external oscillator.	CMOS SCHMITT INPUT
15	CP _{OUT}	Reference Frequency Output Terminal	Terminal for divided output from the crystal reference frequency divider. Normally connected to CP _{IN} .	CMOS OUTPUT
13	TEST	Output Terminal for INTERNAL TEST	Output terminal for INTERNAL TEST. Generally open.	—

TC9242P - 2

1994 - 7 - 15

TOSHIBA CORPORATION

EXPLANATION OF OPERATION

1. Crystal Oscillation Terminals (X_T , $\overline{X_T}$)

- The crystal oscillator is used by connecting as shown below.

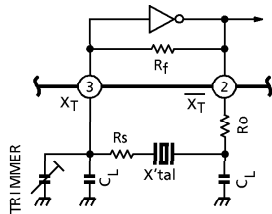

※ CL of 10~30pF is appropriate.

- Crystal oscillation frequency is calculated by the following equation according to number of FG pulses of a motor to be used.

$$f_X = \frac{R}{60} \times FG' \times 128 \times (20 \text{ or } 27) \times N \text{ (Hz)}$$

Note : (20 or 27) : 20 at N/W = "H" or NC
27 at N/W = "L"

Further, fX : Crystal oscillation frequency, FG' : No. of FG pulses generated per revolution of motor.

N : Ratio of frequency division of the crystal reference frequency divider.
N = 3, 4, 5 (Refer to Item 9.)

- Maximum operating frequency is above 20MHz and crystals up to 20MHz can be used.
- If necessary, adjust R_o, R_s and C_L to control noise from the crystal oscillator circuit or to control overtone oscillation.

<Reference values>

f _{X_T} (MHz)	R _o (Ω)	R _s (Ω)	C _L (pF)
20	—	220	22
12	—	220	27
8	—	220	30
4.5	2.2k	—	30
1.5	4.7k	—	30

Note : The values in the table are the reference values. Determine the values suitable for the characteristics of the crystal used.

Note : When not using the crystal oscillator circuit, always connect pin 3 (X_T) to GND as shown in the diagram to overcome the effects of noise and to reduce current consumption.

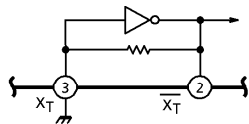

<When not using the crystal oscillator circuit>

2. Reference Frequency Input/Output Terminals (CP_{OUT}, CP_{IN})

- Divided output $\frac{f_x}{N}$ from the crystal reference frequency divider is available at CP_{OUT}, which is normally connected to CP_{IN}.
- When an external oscillator (CR oscillator, etc.) is connected to CP_{IN}, motor speed can be finally adjusted.
- If the effects of noise from CP_{IN} input signal overshoot must be controlled, connect capacitor C1 as in the following diagram.

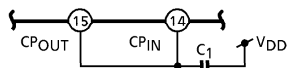

Note : When connecting capacitor C1, make sure that the input level of pin 14 (CP_{IN}) does not fall below the standard ($V_{IH} \geq 0.8 \times V_{DD}$, $V_L \leq 0.2 \times V_{DD}$)

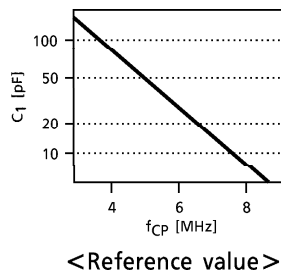

3. FG Pulse Input Terminal (FG_{IN})

- This is the input terminal of FG pulse that shows the motor speed. This FG pulse becomes comparison frequency.
- This terminal has built-in Amplifier and Schmitt circuit. FG pulses are applied through capacitor coupling and small amplitude is enough for proper operation.
- If there is noise in the FG signal, connect capacitor C2 as shown in the diagram to control the noise.

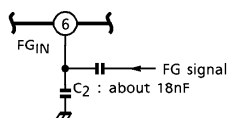

Note : Determine the values of capacitors C1 and C2 after checking their characteristics with f_{CP} and f_{FG} used.

Note : When connecting capacitor C2, make sure that the input level of pin 6 (FG_{IN}) does not fall below the standard ($V_{inFG} \geq 0.5V_{p-p}$)

4. Lock Range Switching Terminal (N/W)

This terminal is for switching the Lock range with a pull-up resistor and chattering preventive circuit.

(TRUTH TABLE)

N / W	DIVIDED FREQUENCY	LOCK RANGE
L	$\frac{1}{27}$	+ 3.4~ - 3.9% of reference cycle
H or NC	$\frac{1}{20}$	+ 4.6~ - 5.3% of reference cycle

CAUTION reference frequency $FS = f_x / N \times (20 \text{ or } 27) \times 128 \text{ (Hz)}$, $FS' = \frac{FS}{2}$

TC9242P - 4

1994 - 7 - 15

TOSHIBA CORPORATION

5. APC, AFC Output Terminal (APC, AFC)

- AFC (speed control output) is a F-V converter for FG frequency and is consisting of a 8bit D/A converter.
- APC (phase control output) is a phase comparator (ϕ -V converter) that compares phase difference ϕ between 1/2 FG and reference frequency FS' , and is also consisting of a 8bit D/A converter.

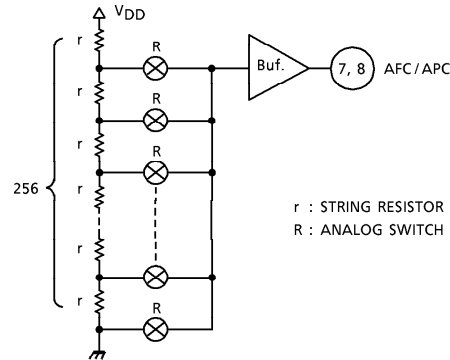

- Both APC and AFC perform the following 3 operations according to FG_{IN} frequency.
 - When FG_{IN} frequency is within the lock range:
Both APC and AFC perform the normal operation for FG_{IN} .
 - When FG_{IN} frequency is below the lock range (under speed):
APC and AFC outputs are both fixed at "H" level.
 - When FG_{IN} frequency is above the lock range (over speed):
APC and AFC outputs are both fixed at "L" level.
- When a motor is in STOP state ($P/S = H$ or NC), both AFC and APC are fixed "L" level.

AFC output change status for FG_{IN} frequency

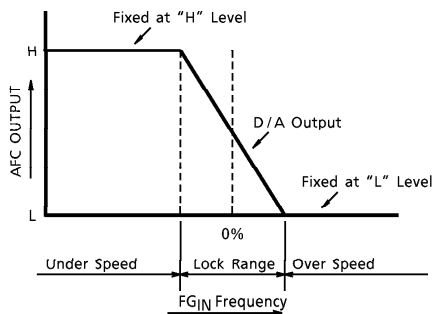

APC output change status for phase difference ϕ

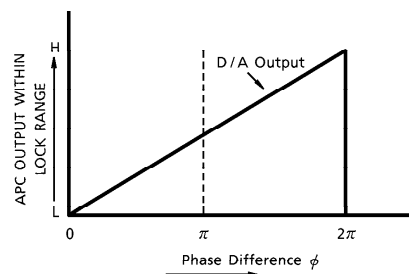

- AFC and APC timing chart within lock range.

a. AFC (SPEED CONTROL SYSTEM)

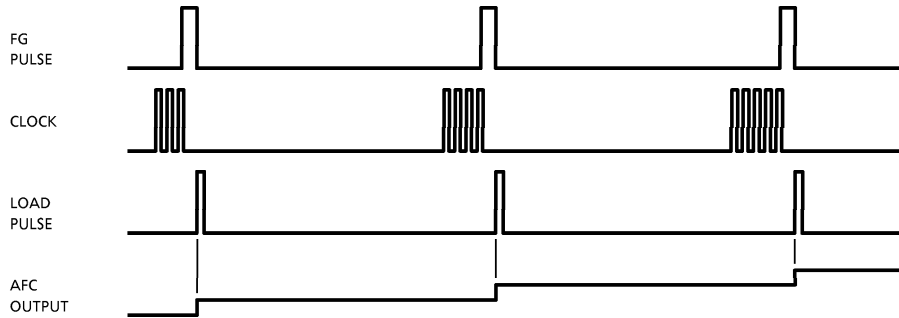

b. APC (PHASE CONTROL SYSTEM)

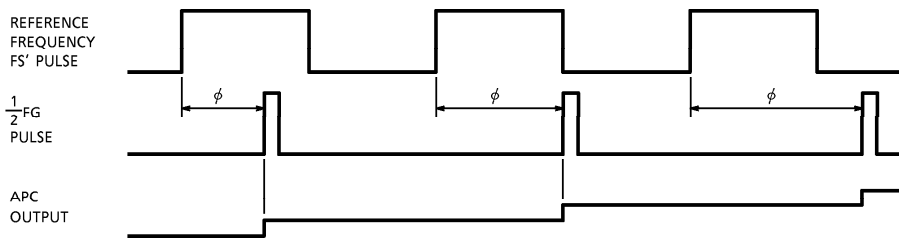

AFC OUTPUT with in Lock Range

6. Lock Detecting Terminal (LD)

- This terminal is the lock detecting output and is placed at "H" level when FG_{IN} frequency is within the lock range and otherwise, placed at "L" level.

7. RUN/STOP Input Terminal (R/S)

- RUN/STOP signals of the motor are input to this terminal.
PLAY=L, STOP=H or NC.
- This terminal has a pull-up resistor and a chattering preventive circuit.
- During RUN (R/S=L), AFC, APC and LD perform the above-mentioned operations for FG_{IN} frequency, and during STOP (R/S=H or NC), AFC, APC and LD are all fixed at "L" level.

8. Reverse Signal Output Terminal (RV)

- Reverse signal for braking the motor at time of switching of Lock range from 1/20 to 1/27 or the operation from RUN to STOP is output through this terminal.
- Change of RV output status

PREVIOUS STATUS	RV OUTPUT CHANGE TO "H" LEVEL	RV OUTPUT CHANGE TO "L" LEVEL
During Normal Rotation (During Lock) at 1/20	When the Lock range is switched from 1/20 to 1/27.	When the Lock range is locked at 1/27, or When $FG_{IN} \leq 1/8FS$, or when the Lock range is switched from 1/27 to 1/20.
During Normal Rotation (During Lock) at 1/20 or 1/27	When the operation is switched from RUN to STOP.	When $FG_{IN} \leq 1/8FS$ or when the operation is switched from STOP to RUN.

- In other cases than above, RV output is not changed and fixed at "L" level.
- Further, if FG frequency rises up to 1.5 times of normal rotation at 1/20 (2 times of normal rotation at 1/27), RV output is reset.

9. Reference Divided Frequency Switching Terminal (N₁, N₂)

- Divided frequency 1/N of the crystal reference frequency divider can be switched to 1/5, 1/4 or 1/3 by number of FG pulses or a crystal used.
- This terminal has a built-in pull-up resistor.

(TRUTH TABLE)

N1	N2	1/N
H	H	1/5
L	H	1/4
H	L	1/3

1/N : Crystal reference divided frequency

Note : Do not use N1=N2=L, which is used for internal test only.

MAXIMUM RATINGS (Ta = 25°C)

CHARACTERISTIC	SYMBOL	RATING	UNIT
Supply Voltage	V _{DD}	-0.3~7.0	V
Input Voltage	V _{IN}	-0.3~V _{DD} + 0.3	V
Power Dissipation	P _D	300	mW
Operating Temperature	T _{opr}	-40~85	°C
Storage Temperature	T _{stg}	-65~150	°C

ELECTRICAL CHARACTERISTICS (Unless otherwise specified Ta = 25°C, V_{DD} = 5V)

CHARACTERISTIC	SYMBOL	TEST CIRCUIT	TEST CONDITIONS	MIN.	TYP.	MAX.	UNIT	
Operating Supply Voltage	V _{DD}	—	※	4.5	5.0	5.5	V	
Operating Supply Current	I _{DD}	1	X'tal = 20MHz, CP _{in} = CP _{out}	—	15.0	25.0	mA	
Operating Frequency Range	X _T	f _{XT}	2	※	1.5	~	20.0	MHz
	CP _{in}	f _{CP}	3	V _{in} Square Wave	0.3	~	10.0	MHz
	FG _{in}	f _{FG}	—	V _{in} = 0.5V _{p-p} Sine Wave	—	~	4.0	kHz
Input Amplitude Voltage	FG _{in}	V _{inFG}	4	f _{FG} = 4kHz, Sine Wave, AC input	0.5	~	V _{DD} - 0.5	V _{p-p}
AFC, APC D/A Converter	Deviation	—	—	—	±2.0	±4.0	LSB	
	Resolution	—	—	—	V _{DD} /256	—	V	
Pull-up Resistor	R _{in}	—	N1, N2, N/W, R/S	15	30	60	kΩ	
Input Voltage	"H" Level	V _{IH}	—	N1, N2, N/W, R/S, CP _{in}	V _{DD} × 0.8	~	V _{DD}	V
	"L" Level	V _{IL}	—	N1, N2, N/W, R/S, CP _{in}	0	~	V _{DD} × 0.2	
Input Leak Current	I _{IH}	—	—	CP _{in}	—	—	±1.0	μA
	I _{IL}	—	—	CP _{in}	—	—	±1.0	
Output Current	"H" Level	I _{OH}	—	RV, LD, CP _{out} V _{OH} = 4.5V	-0.5	-2.5	—	mA
	"L" Level	I _{OL}	—	RV, LD, CP _{out} V _{OL} = 0.5V	0.5	2.5	—	
	"H" Level	I _{OH}	—	APC, AFC V _{OH} = 4.5V	-0.3	-1.0	—	μA
	"L" Level	I _{OL}	—	APC, AFC V _{OL} = 0.5V	25	75	—	
Amplifier Feedback Resistor	X _T	R _f	5	—	150	330	660	kΩ
	FG _{in}	R _f	5	—	150	330	660	kΩ

※ : Guaranteed within the range of V_{DD} = 4.5~5.5V, Ta = -40~85°C

TEST CIRCUIT

1. Operating Supply Current I_{DD}

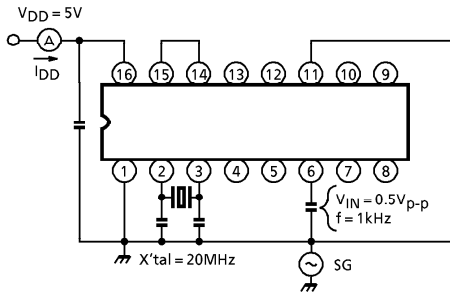

2. X_T Operating Frequency Range f_{MAX} (f_{XT})

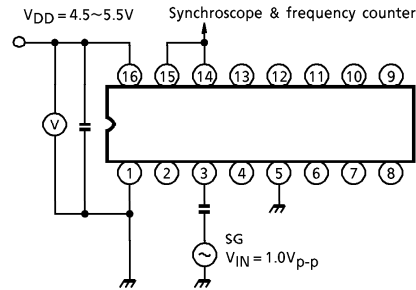

3. CP_{IN} Operating Frequency Range f_{MAX} (f_{CP})

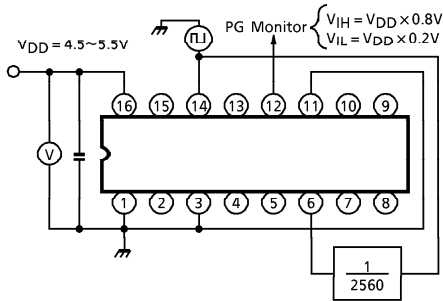

4. FG_{IN} Input Sensitivity V_{INFG}

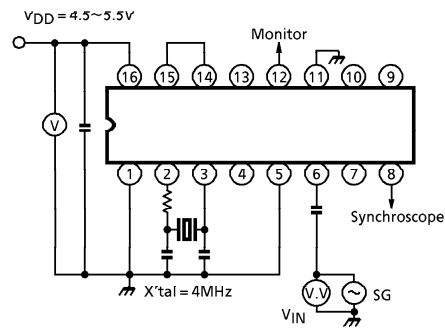

5. Amplifier Feedback Resistor R_f

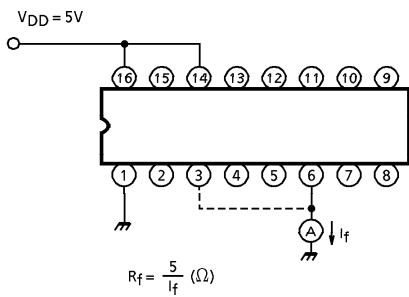

APPLICATION CIRCUIT

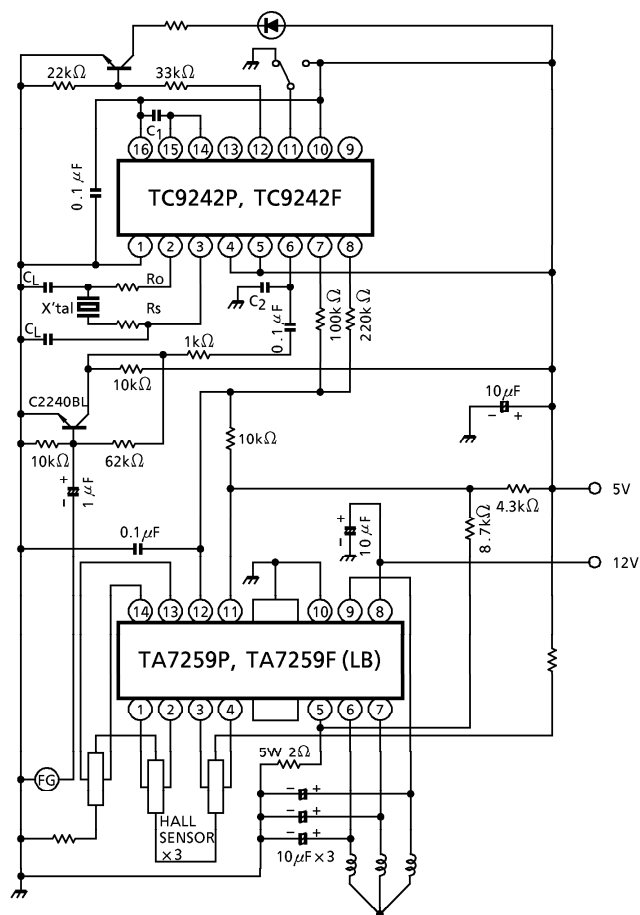

- Example of crystal oscillation frequency calculation.

When FG' (number of FG pulse) = 180 pulses and R (revolution of motor) = 200rpm., if the dividing frequency of reference divider and lock range is set at N = 5 dividing frequency and N/W = 20, the crystal oscillation frequency f_x is as follows :

$$f_x = \frac{R}{60} \times FG' \times 128 \times 20 \times N = \frac{200}{60} \times 180 \times 128 \times 20 \times 5 = 7.68\text{MHz}$$

- Select the external filter of the differential amplifier in the application circuit depending on the response characteristics of the motor used.
- Determine values C1, C2, CL, Ro and Rs in the application circuit depending on the characteristics of the circuit.

TC9242P - 10

1994 - 7 - 15

TOSHIBA CORPORATION

OUTLINE DRAWING
DIP16-P-300A

Unit : mm

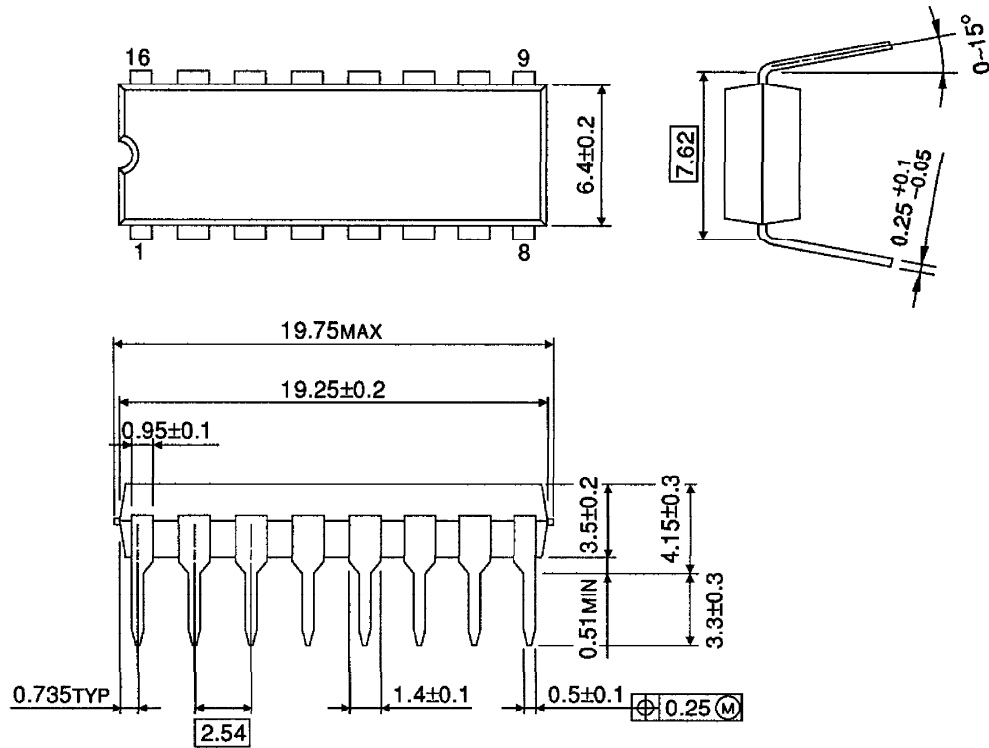

Weight : 1.00g (Typ.)

TC9242P - 11
1994 - 7 - 15
TOSHIBA CORPORATION

OUTLINE DRAWING
SOP16-P-300

Unit : mm

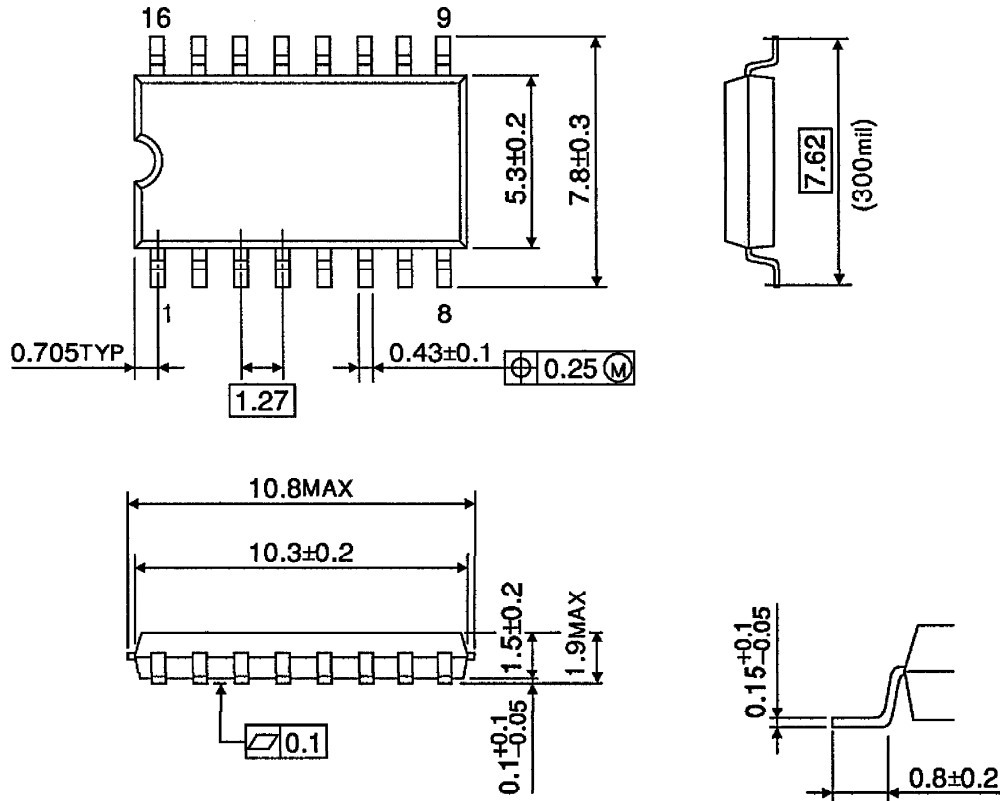

Weight : 0.16g (Typ.)

TC9242P - 12*

1994 - 7 - 15

TOSHIBA CORPORATION