

TOSHIBA Bi-CMOS INTEGRATED CIRCUIT SILICON MONOLITHIC

TB6515AP

SENSORLESS MOTOR DRIVER IC

The TB6515AP is a sensorless motor driver IC developed mainly for use with VTR cylinder motors. The PG and FG sensors are sensorless three-phase brushless motor driver ICs with sharing capabilities (specific magnetism is required).

FEATURES

- The PG and FG sensors can be shared, and the motor driver areas are sensorless.
- Three-phase full-wave drive models.
- Equipped with FG output.
- Built-in thermal shut-down circuits.
- Built-in power source for the PG and FG sensors.

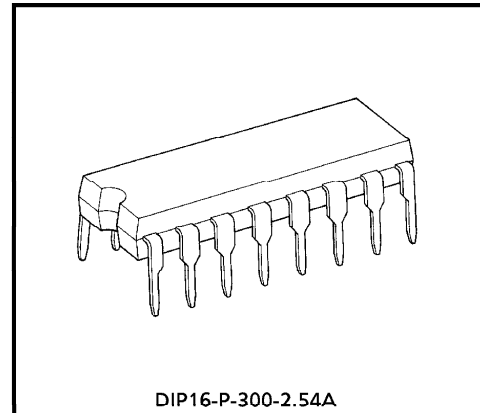

DIP16-P-300-2.54A

Weight : 1.11g (Typ.)

BLOCK DIAGRAM

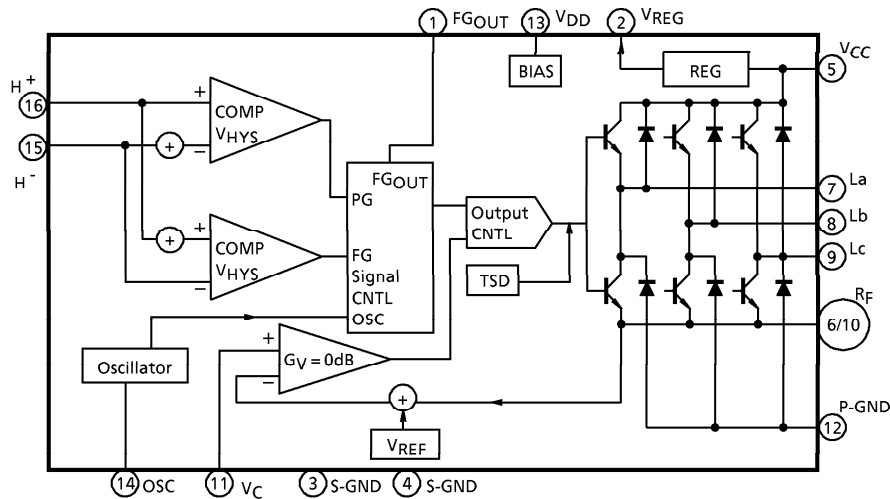

961001EBA1

- TOSHIBA is continually working to improve the quality and the reliability of its products. Nevertheless, semiconductor devices in general can malfunction or fail due to their inherent electrical sensitivity and vulnerability to physical stress. It is the responsibility of the buyer, when utilizing TOSHIBA products, to observe standards of safety, and to avoid situations in which a malfunction or failure of a TOSHIBA product could cause loss of human life, bodily injury or damage to property. In developing your designs, please ensure that TOSHIBA products are used within specified operating ranges as set forth in the most recent products specifications. Also, please keep in mind the precautions and conditions set forth in the TOSHIBA Semiconductor Reliability Handbook.
- The products described in this document are subject to foreign exchange and foreign trade control laws.
- The information contained herein is presented only as a guide for the applications of our products. No responsibility is assumed by TOSHIBA CORPORATION for any infringements of intellectual property or other rights of the third parties which may result from its use. No license is granted by implication or otherwise under any intellectual property or other rights of TOSHIBA CORPORATION or others.
- The information contained herein is subject to change without notice.

PIN FUNCTION

PIN No.	PIN SYMBOL	PIN FUNCTION
1	FGOUT	FG signal output pin
2	VREG	Internal power source voltage output pin
3	S-GND	Small signal ground pin
4	S-GND	Small signal ground pin
5	VCC	Power source applied voltage pin
6	R _F	Output current detection pin
7	La	a-phase drive output pin
8	Lb	b-phase drive output pin
9	Lc	c-phase drive output pin
10	R _F	Output current detection pin
11	V _C	Control amplifier positive input pin
12	P-GND	Output ground pin
13	VDD	Internal power source voltage output pin
14	OSC	Oscillation condenser connection pin
15	H ⁻	PG / FG comparator negative input pin
16	H ⁺	PG / FG comparator positive input pin

MAXIMUM RATINGS (Ta = 25°C)

CHARACTERISTIC	SYMBOL	RATING	UNIT
Power Suplly Voltage	V _{CC}	18	V
Output Current	I _O	1.0	A
Regulator Output Current	I _{REG}	12	mA
FG Output Current	I _{FG}	2.0	mA
Power Dissipation	P _D	(Note) 1.2	W
Operating Temperature	T _{opr}	- 30 ~ 85	°C
Storage Temperature	T _{stg}	- 55 ~ 150	°C

(Note) IC units

ELECTRICAL CHARACTERISTICS ($V_{CC} = 12V$, $T_a = 25^\circ C$)

CHARACTERISTIC		SYMBOL	TEST CIR-CUIT	TEST CONDITION	MIN.	TYP.	MAX.	UNIT
Power Supply Current		I_{CC1}	1	$V_{CC} = 12V, V_C = 0V, V_{REG} = OPEN$	—	9.0	15	mA
		I_{CC2}	1	$V_{CC} = 18V, V_C = 0V, V_{REG} = OPEN$	—	9.3	15	
Control Amplifier	Standard Voltage	V_{ref}	2		—	2.6	—	V
	Voltage Gain	G_V	6		—	1.0	—	
	Input Current	I_{IN}	2	$V_C = 3.5V$	—	2.5	10	μA
Leak Current	Upper	$I_{OL(U)}$	—	$V_{CC} = 18V, V_C = 0V$	—	—	50	μA
	Lower	$I_{OL(L)}$		$V_{CC} = 18V, V_C = 0V$	—	—	50	
Output Saturation Voltage	Upper	$V_{sat(U)}$	3	$I_O = 1A$	—	1.5	1.9	V
	Lower	$V_{sat(L)}$		$I_O = 1A$	—	0.8	1.2	
Correlated Gain Difference		ΔG_V	—		—	—		%
Residual Output Voltage		V_{or}	6	$V_C = 0V$	—	0	10	mV
FG / PG Threshold Level	FG Upper Level	V_{FGH}	5	L → H	91	104	117	mV
	FG Lower Level	V_{FGL}		H → L	108	121	134	
	PG Upper Level	V_{PGH}		L → H	118	131	144	
	PG Lower Level	V_{PGL}		H → L	139	152	165	
Hall Amp Common-Mode Input Voltage		CMR	—			—	2.0	V
FG Output Voltage		$V_{FG(L)}$	4	$I_{FG} = 1mA$	—	—	1.1	V
FG Output Current		I_{FG}	—		1.8	2.0	—	mA
Delta-Wave Oscillation Frequency		f_{OSC}	7	$C_{OSC} = 0.1\mu F$	—	8	—	Hz
Rated Voltage Output Circuit	Output Voltage	V_{REG}		$RL = 200\Omega : 5V$	1.35	1.45	1.55	V
	Temperature Variable	ΔV_O	1	$RL = 200\Omega, T_j = -20\sim 70^\circ C$	—	± 30	—	mV
	Output Current	I_{REG}	—		20	—	—	mA
Thermal Shut-Off Circuit Operating Temperature		TSD	—		150	—	—	$^\circ C$

TEST CIRCUIT 1.

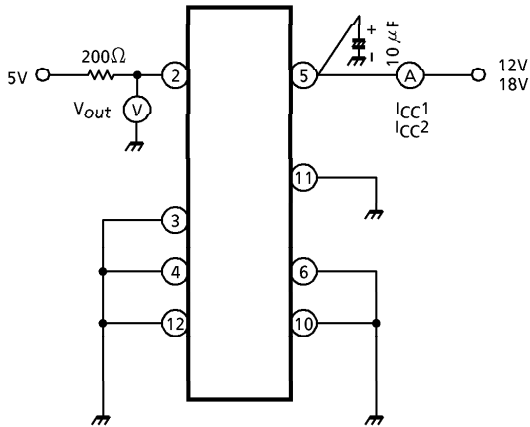

TEST CIRCUIT 2.

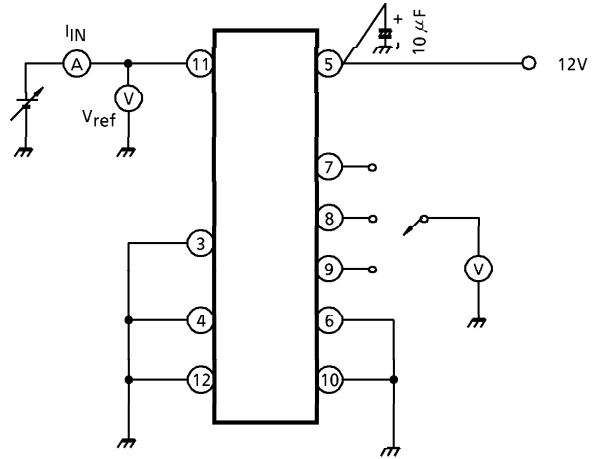

TEST CIRCUIT 3.

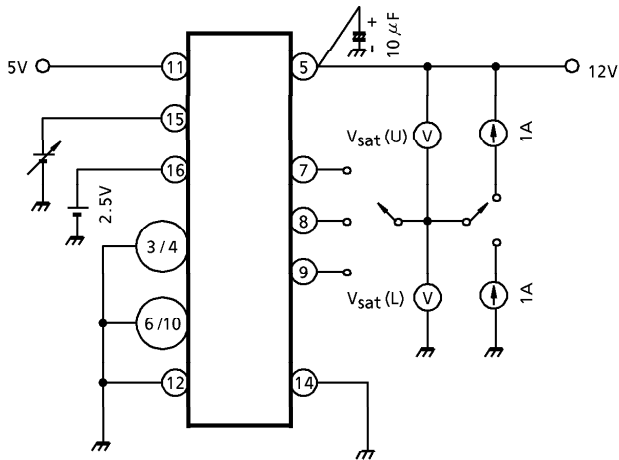

TEST CIRCUIT 4.

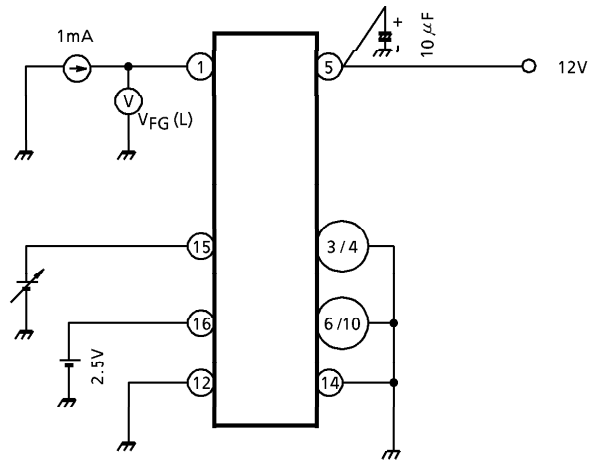

TEST CIRCUIT 5.

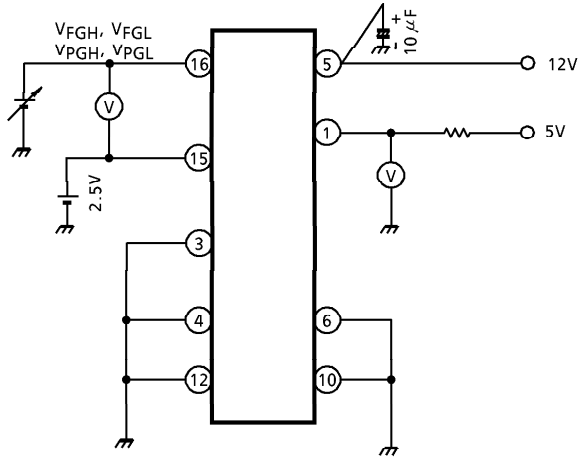

TEST CIRCUIT 6.

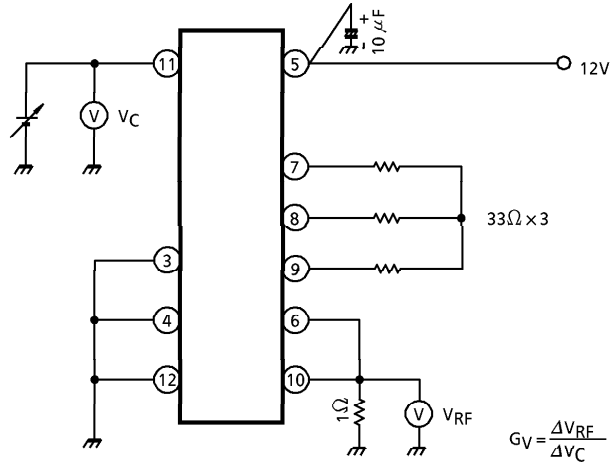

TEST CIRCUIT 7.

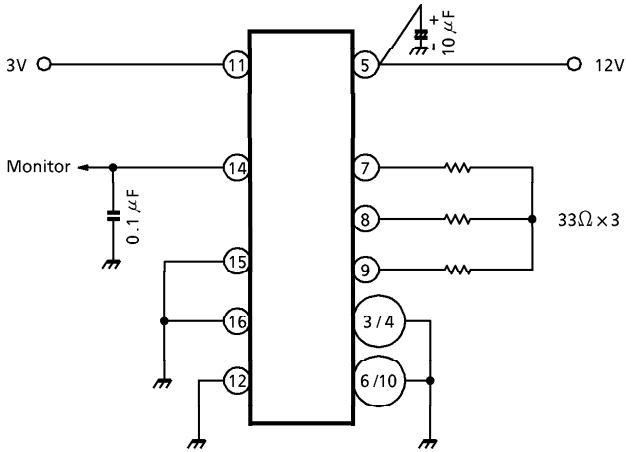

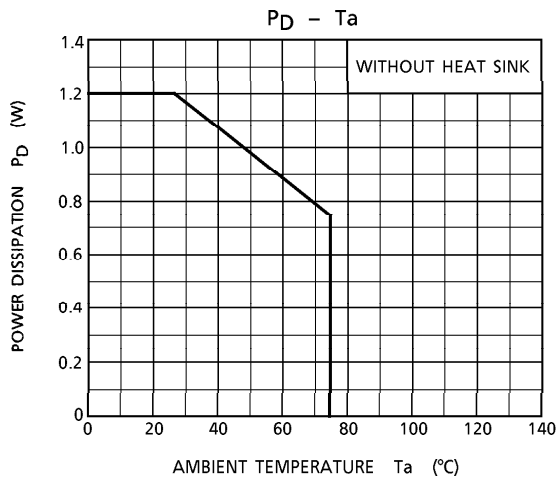

APPLICATION CIRCUIT

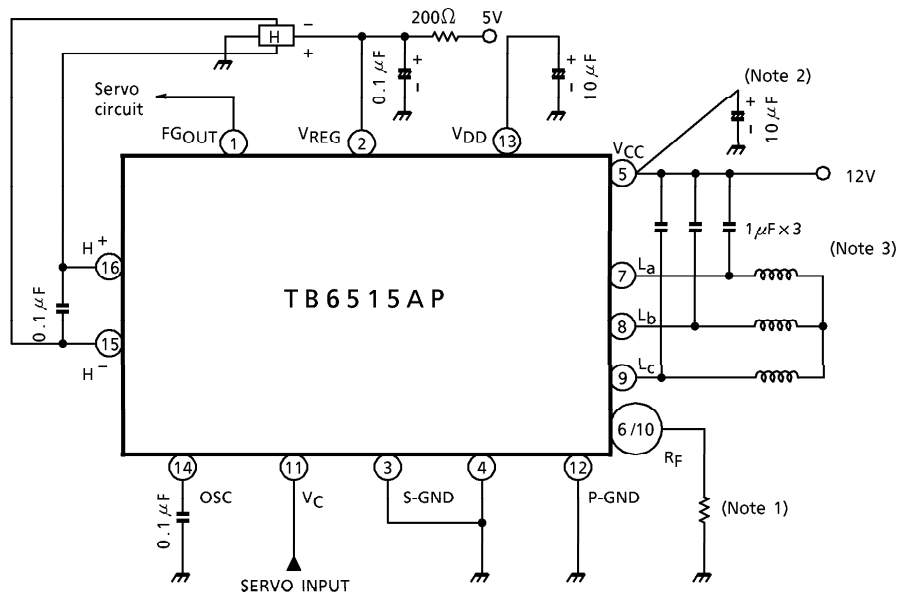

- (Note 1) R_f is determined in accordance with coil impedance, F/V conversion voltage (control input), the required torque and other factors, but between approximately 0.3Ω and 5Ω should be used.
- (Note 2) It is recommended that the IC pin and GND are connected directly. Ever larger levels of capacity may be required depending on the shared impedance of the power source line.
- (Note 3) There may be cases where connections (various output → GND, etc.) and capacity needs to be amended in order to prevent noise and vibrations from the motor.

OUTLINE DRAWING
DIP16-P-300-2.54A

Unit : mm

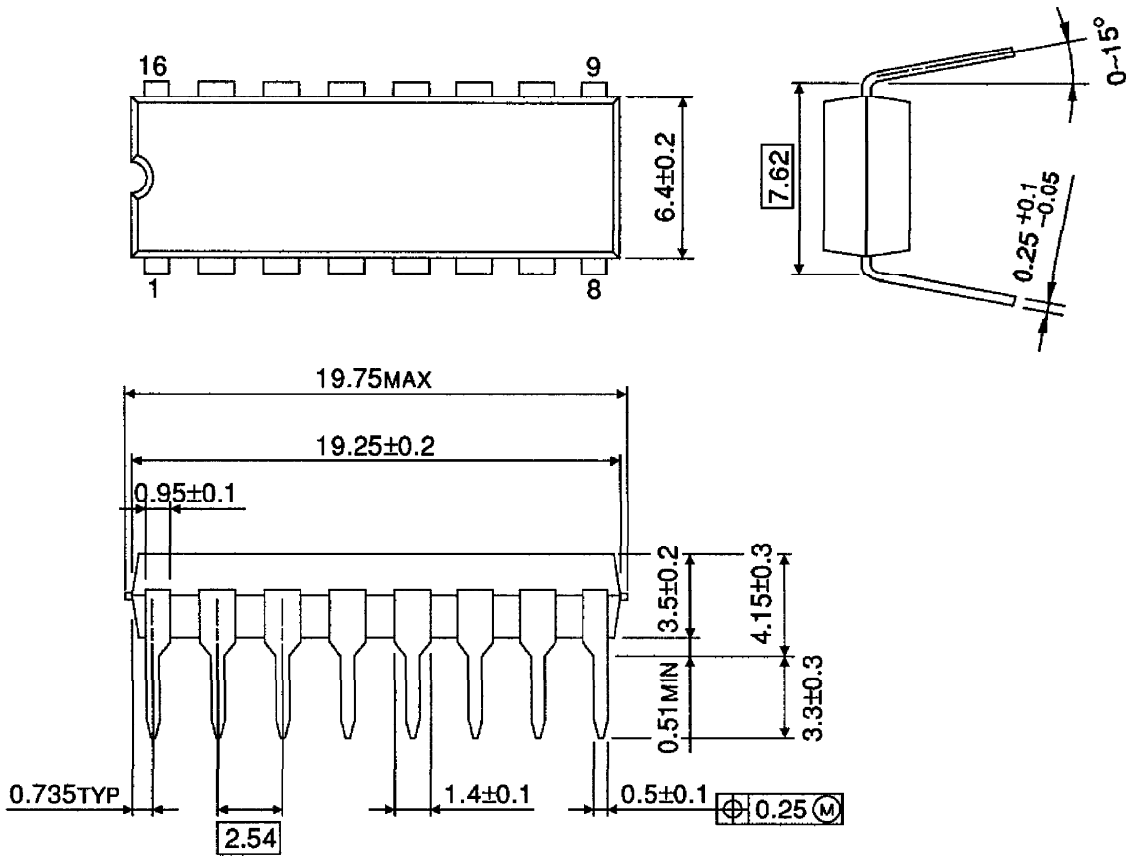

Weight : 1.11g (Typ.)