

## PIF QIF SYSTEM FOR TV

### FEATURES

#### PIF section

- 3-stage variable gain PIF amplifier
- High-speed response AGC with dual time constants
- Single end AFT output with defeat function
- Delayed RF AGC output (Reverse AGC)
- Black / White noise inverter
- The AFT polarity of TA8712N different from TA8796N

#### QIF section

- Intercarrier demodulation section by the same configuration as PIF section.
- Independent average AGC circuit

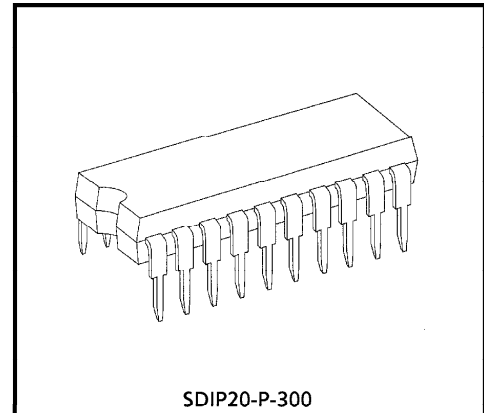

Weight : 1.02g (Typ.)

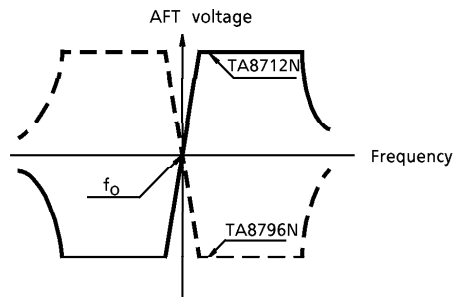

**BLOCK DIAGRAM**

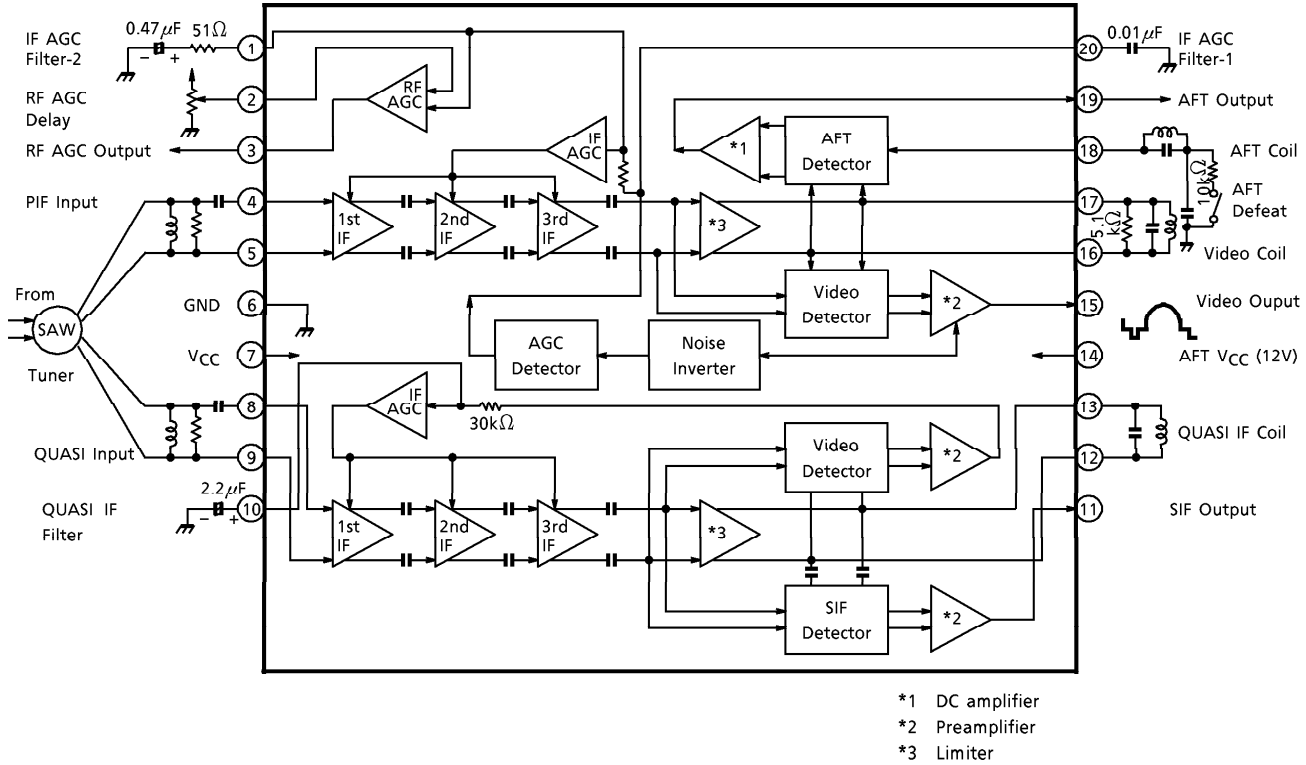

**TERMINAL FUNCTION**

PIN No.	PIN NAME	FUNCTION	INTERFACE CIRCUIT
1 20	AGC Filter	This filter is a dual time constant system to speed up AGC. By connecting the primary filter terminal of pin 20 to GND, a picture muting is executed.	
2	AGC Delay	This terminal adjusts the delay point of RF AGC by varying the reference voltage of comparator.	

PIN No.	PIN NAME	FUNCTION	INTERFACE CIRCUIT
3	RF AGC Output	Since this is an open collector output, the gain is determined by an external resistor.	
4 5	PIF Input	This is an input terminal of PIF signal using an emitter follower. The input impedance is typical 2.5kΩ, 4pF.	
8 9	QIF Input	This is a quasi input terminal and connects a sound output of dual SAW filter. When not using QUASI, connect this pin to GND by capacitor.	
10	AGC Filter	This connects QIF AGC filter. Since AGC is executed by a video signal, there is no worry about the IF amplifier saturation by the video signal even if the P/S ratio is greater like CATV.	
11	QUASI Output	Because SIF is detected by a video carrier of 90° phase shifted, the video signal will affect less and buzz will largely be improved.	

PIN No.	PIN NAME	FUNCTION	INTERFACE CIRCUIT
12 13	QUASI Coil	In order to influence less on video signal buzz, the multiple detection is executed by a 90° phase shifter of video carrier. Connect the tuning coil circuit of carrier whose phase was 90° shifted to pins 12 and 13.	
15	Video Output	This is a Video output terminal. By connecting the primary filter terminal of pin 20 to GND, a picture muting is executed.	
16 17	Video Coil	This connects a coil for video detection.	
18	AFT Coil	Supply a control signal by single end. This method is that the phase difference is treated as current and voltage is converted by an external resistor. Therefore, this can be connected to AFT using only one pin. By connecting a resistor of 5.1kΩ to GND, an AFT defeat can be executed.	
19	AFT Output	By connecting an AFT coil pin to GND, a muting is executed.	

**MAXIMUM RATINGS** (Ta = 25°C)

CHARACTERISTIC	SYMBOL	RATING	UNIT
Supply Voltage	V <sub>CC</sub>	15	V
Power Dissipation	P <sub>D</sub> (Note)	1.4	W
Operating Temperature	T <sub>opr</sub>	- 20~65	°C
Storage Temperature	T <sub>stg</sub>	- 55~150	°C

(Note) When using the device at above Ta = 25°C, decrease the power dissipation by 11.2mW for each increase of 1°C.

**RECOMMENDED SUPPLY VOLTAGE**

PIN No.	PIN NAME	MIN.	TYP.	MAX.	UNIT
7	V <sub>CC</sub>	8.1	9.0	9.9	V

**ELECTRICAL CHARACTERISTICS**

DC CHARACTERISTICS (Unless otherwise specified, V<sub>CC</sub> = 9V, Ta = 25°C)

CHARACTERISTIC		SYMBOL	TEST CIR-CUIT	TEST CONDITION	MIN.	TYP.	MAX.	UNIT
Supply Current		I <sub>CC</sub>	1	—	45	60	75	mA
Terminal Voltage	Pin 4	V <sub>4</sub>	1	—	3.5	4.0	4.5	V
	Pin 5	V <sub>5</sub>			3.5	4.0	4.5	
	Pin 8	V <sub>8</sub>			3.5	4.0	4.5	
	Pin 9	V <sub>9</sub>			3.5	4.0	4.5	
	Pin 11	V <sub>11</sub>			3.0	3.5	4.0	
	Pin 15	V <sub>15</sub>			4.1	4.4	4.7	
	Pin 19	V <sub>19</sub>			5.0	6.5	8.0	

AC CHARACTERISTICS (Unless otherwise specified,  $V_{CC} = 9V$ ,  $T_a = 25^\circ C$ )  
PIF section (when using the specified video coil)

CHARACTERISTIC	SYMBOL	TEST CIR-CUIT	TEST CONDITION	MIN.	TYP.	MAX.	UNIT
Input Sensitivity	$V_{IN}$	2	(Note 1)	28	34	42	$dB/\mu V$
Sync. Tip Level Voltage	$V_{SYNC}$	2	(Note 2)	1.5	2.0	2.5	V
AFT Sensitivity	$\Delta f / \Delta V$	2	(Note 3)	—	22	30	$kHz/V$
AGC Range	$\Delta A$	2	(Note 4)	60	—	—	dB
AFT Output Voltage	Max. $V_U$	2	(Note 5)	7.5	8.0	—	V
	Min. $V_L$			—	1.0	1.5	
Black Noise Threshold Level	$V_{BTH}$	2	(Note 6)	—	1.5	—	V
Black Noise Clamp Level	$V_{BCL}$			—	3.0	—	
White Noise Threshold Level	$V_{WTH}$			—	5.2	—	
White Noise Clamp Level	$V_{WCL}$			—	3.5	—	
Carrier Wave Suppression Ratio	$V_{CL}$	4	(Note 7)	40	50	—	dB
Secondary Harmonics Suppression Ratio	$V_{2nd}$	4	(Note 8)	35	50	—	dB
Differential Gain	DG	5	(Note 9)	—	4	7	%
Differential Phase	DP			—	3.0	5.0	°
Input Impedance	$R_{IN}$	—	—	1.0	2.5	4.0	$k\Omega$
	$C_{IN}$	—	—	—	3	6	pF
Intermodulation	$I_M$	4	(Note 10)	31	58	—	dB

QUASI section (when using the specified quasi coil)

CHARACTERISTIC	SYMBOL	TEST CIR-CUIT	TEST CONDITION	MIN.	TYP.	MAX.	UNIT
Input Sensitivity	$V_{IN}$	2	(Note 11)	30	36	42	$dB/\mu V$
Gain Reduction Characteristic	GR	2	(Note 12)	60	64	—	dB
4.5MHz Output Level	$V_{QD}$	3	(Note 13)	400	500	—	$mV_{p-p}$
Input Impedance	$R_{IN}$	—	—	1.0	2.5	4.0	$k\Omega$
	$C_{IN}$	—	—	—	3	6	pF
Carrier Suppression Ratio	$C_L$	4	Same as PIF (Note 6)	40	50	—	dB
Secondary Harmonic Suppression Ratio	$I_{2nd}$			40	50	—	

**TEST CONDITIONS**

(Note 1) Input Sensitivity

Input : Supply the P4,  $f = 58.75\text{MHz}$ ,  $f_m = 15.75\text{kHz}$ , 30% AM signal, Internal AGC.  
Measure the input level when the output amplitude of P15A becomes  $0.6\text{V}_{\text{p-p}}$ .

(Note 2) Synchronization Tip Level

Input : Supply the P4,  $f = 58.75\text{MHz}$ ,  $84\text{dB}\mu\text{V}$ , and CW.  
Measure DC voltage of P15.

(Note 3) AFT Sensitivity

Input : Read the variation of P19 when increase / decreasing the frequency by supplying P4,  
 $f = 58.75\text{MHz}$   $84\text{dB}\mu\text{V}$ , and CW.

(Note 4) AGC Range

Input : Supply the P4,  $f = 58.75\text{MHz}$ ,  $f_m = 15.75\text{kHz}$ , 30% AM signal.  
When an external AGC voltage is  $8.5\text{V}$  and  $3.0\text{V}$ , each input level whose output voltage will  
be  $0.6\text{V}_{\text{p-p}}$  is treated as  $V_1$  and  $V_2$ .  
Then, calculate the following equation.

$$\Delta A = 20 \log \frac{V_1}{V_2}$$

(Note 5) AFT Output Voltage

Input : Measure DC voltage of P19 by varying the P4,  $f = 58.75\text{MHz}$ ,  $f_m = 15.75\text{kHz}$ , 30% AM  
signal and internal AGC.  
(Diagram below)

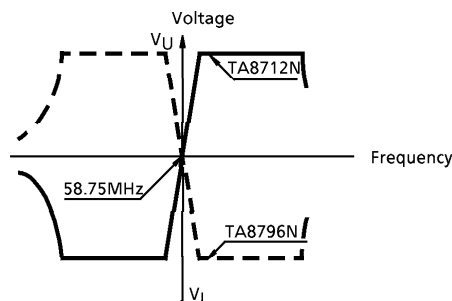

(Note 6) Noise Threshold / Clamp Level

Sweep the input frequency up to external AGC 8.5V, frequency 57~63MHz and observe the output level by monitor scope.

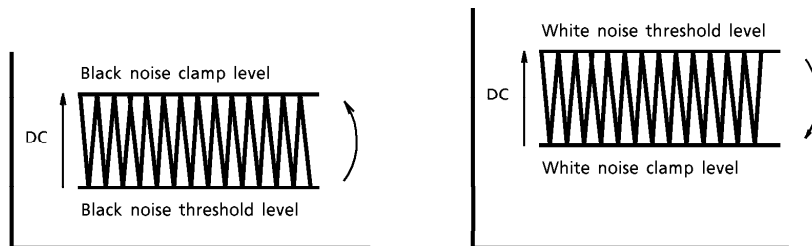

Waveforms by monitor scope

(Note 7) Carrier Suppression Ratio

Input : Supply the P4,  $f = 58.75\text{MHz}$ ,  $f_m = 15.75\text{kHz}$ , 30% AM signal.

Adjust so that the output can be  $2V_{p-p}$  by external AGC.

Calculate the following equation by setting the modulation to 0 and measuring the output carrier level.

$$V_{CL} = 20 \log \frac{2.0}{V_{CR} (V_{p-p})}$$

(Note 8) Secondary Harmonic Suppression Ratio

Calculate the secondary harmonics using the same method as note 7.

(Note 9) Differential Gain, Differential Phase

Adjust the AGC voltage so that the sync. tip level will be 2V by supplying the  $f = 58.75\text{MHz}$ , APL 50%, and 87.5% AM signal. Measure by DG or DP meter.

(Note 10) Intermodulation

SG<sub>1</sub> : 58.75MHz (P) 84dB $\mu$ V, CW.

SG<sub>2</sub> : 54.25MHz (S) 78dB $\mu$ V, CW.

SG<sub>3</sub> : 55.17MHz (C) 78dB $\mu$ V, CW.

Input in combination with the above three signal and adjust the AGC voltage so that the min. D.C. voltage of output will be the same as the sync. tip level. Measure the difference between the chroma signal and 920kHz signal by spectrum analyzer.



(Note 11) Input Sensitivity

Pin 8 input

SG<sub>1</sub> : 58.75MHz (P) 100dB $\mu$ V, CW.

SG<sub>2</sub> : 54.25MHz (S) 90dB $\mu$ V, CW.

Input in combination with the above two signals. Measure the input level so that the detection output will be half by lowering the input level gradually.

(Note 12) Gain Reduction Characteristics

Measure the input level so that the output can be 0.2V<sub>p-p</sub> under the following external AGC supply.

Pin 10 = 8.5V Input level V<sub>1</sub>

Pin 10 = 3.0V Input level V<sub>2</sub>

From the above measurement value,

$$GR = 20 \log (V_1 / V_2) \text{ dB}$$

(Note 13) 4.5MHz Output Level

Measure the output level using the same input level of note 11.

**TEST CIRCUIT 1**

DC characteristic

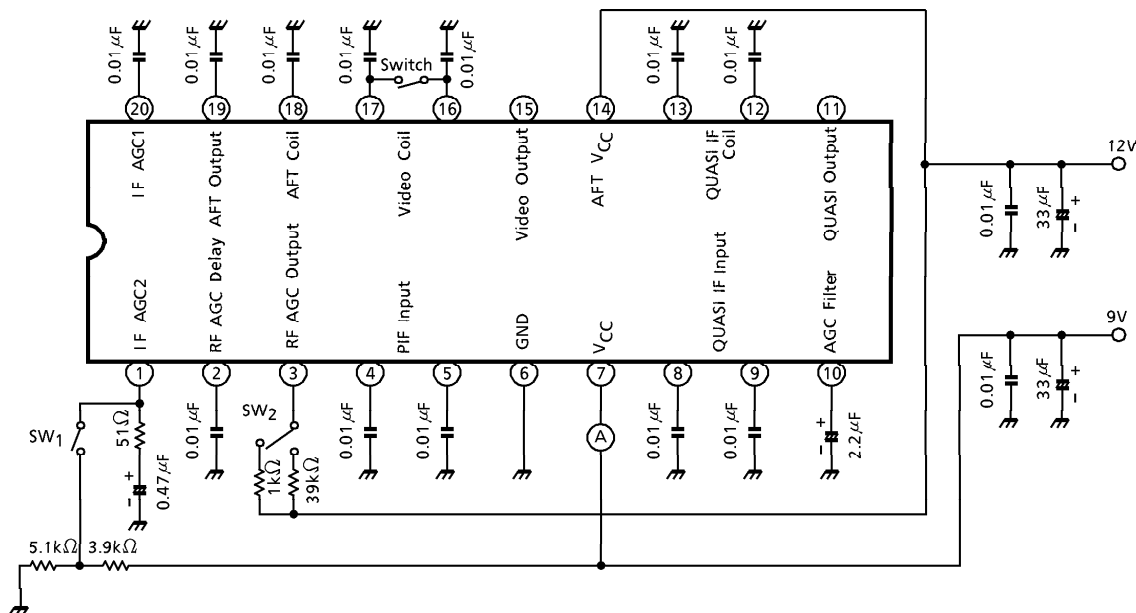

**TEST CIRCUIT 2**  
AC characteristics

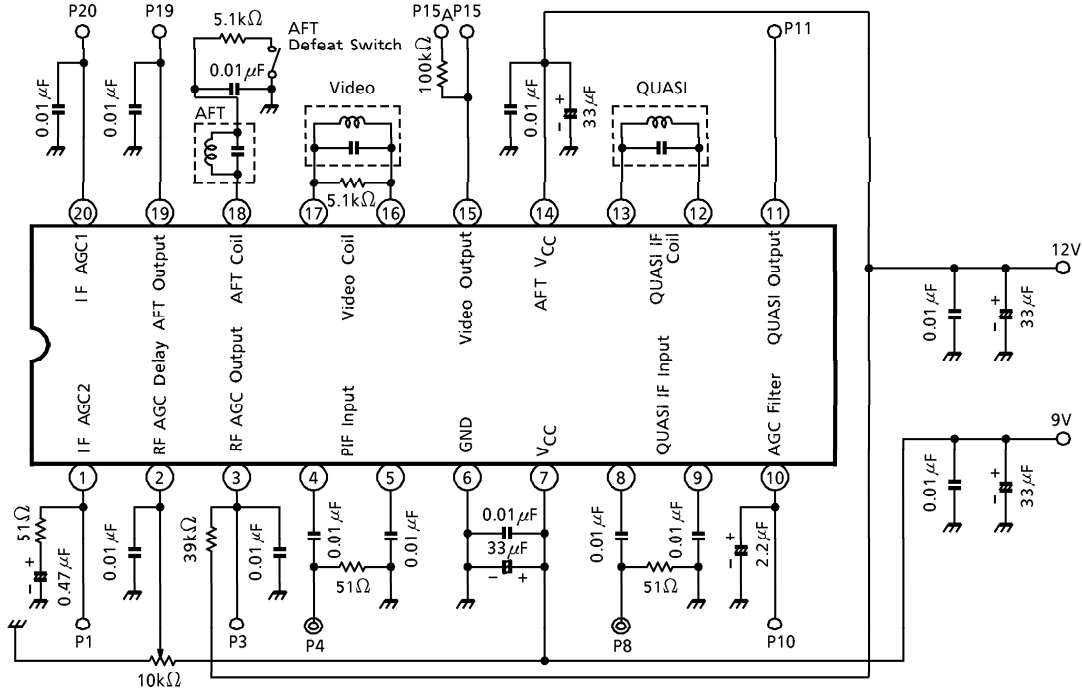

**TEST CIRCUIT 3** QIF detection output  $V_{QD}$

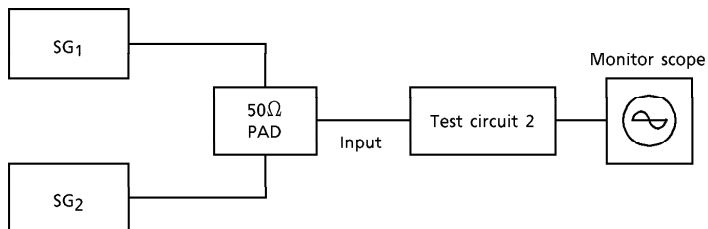

**TEST CIRCUIT 4** Carrier, Secondary harmonic suppression ratio, Intermodulation

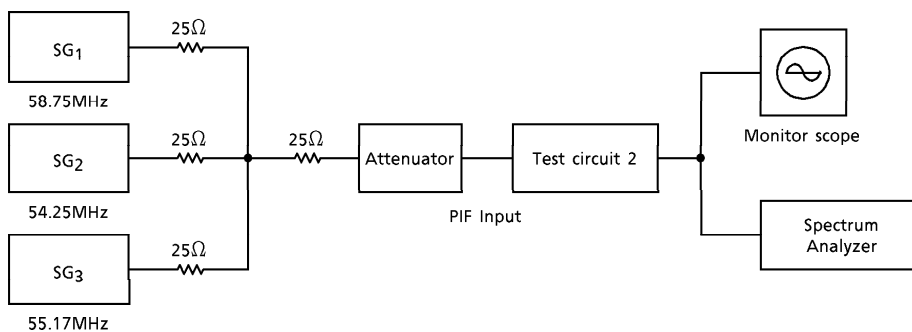

**TEST CIRCUIT 5** Differential phase, differential gain

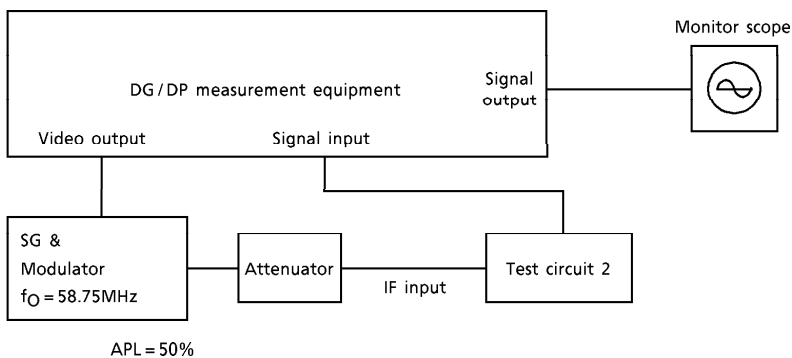

**OUTLINE DRAWING**  
SDIP20-P-300

Unit : mm

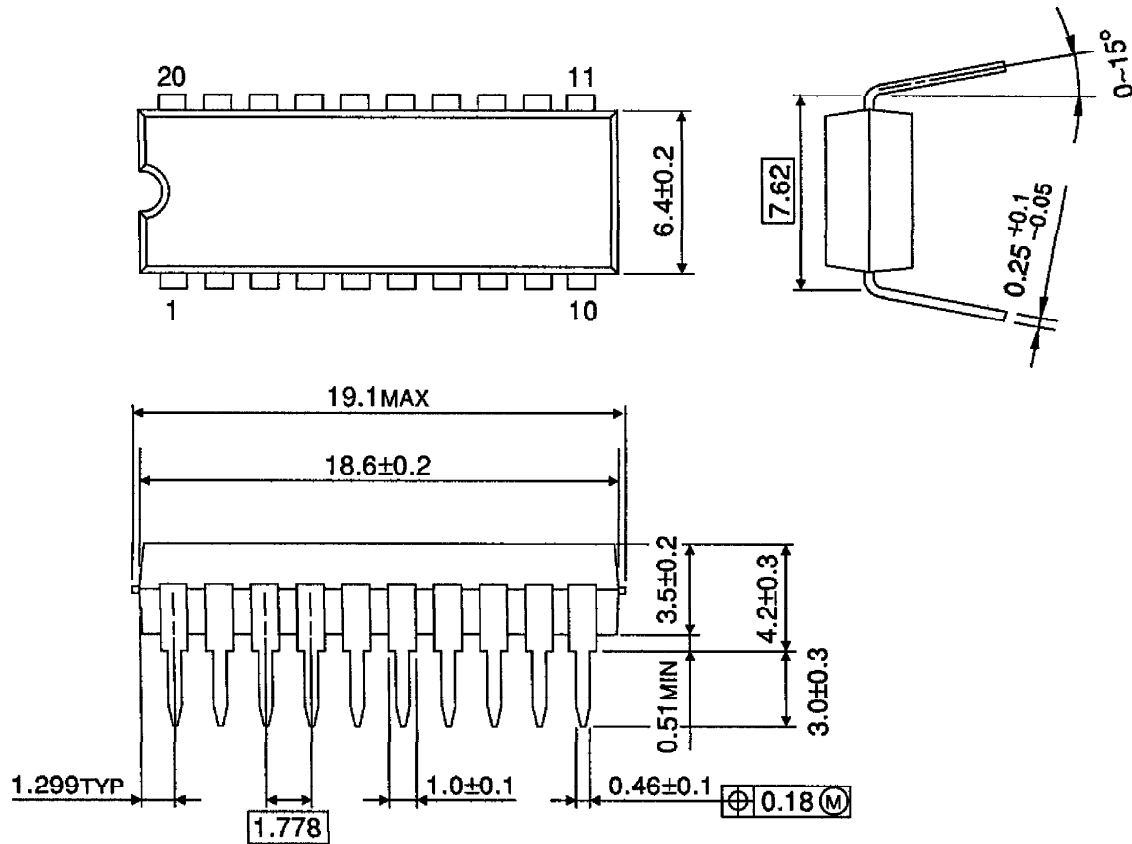

Weight : 1.02g (Typ.)

TA8712N - 12*
1995 - 11 - 13
<b>TOSHIBA CORPORATION</b>