

TENTATIVE DATA

1.5V STEREO HEADPHONE AMPLIFIER

The TA8159FN is developed for play-back stereo headphone equipments (1.5V use). It is built in dual auto-reverse pre amplifiers, dual OCL power amplifiers, and a ripple filter.

FEATURES

Power amp. stage

- OCL (Output Condenser-Less)
- Low noise : $V_{no} = 48\mu V_{rms}$ (Typ.)
- Output Power : $P_o = 6mW$ (Typ.)
(at $V_{CC} = 1.5V$, $f = 1kHz$, THD = 10%)
- Excellent ripple rejection ratio : RR = 54dB (Typ.)
- Voltage Gain : $G_V = 28dB$ (Typ.)
- Built-in power amplifier mute.

Pre-amp. stage

- Auto-reverse with F/R control switch
- Low noise : $V_{ni} = 1.7\mu V_{rms}$ (Typ.)
- Input coupling condenser-less
- Built-in input capacitor for reducing buzz noise
- Built-in pre-amplifier mute

Total

- Built-in ripple filter
- Built-in power switch
- Operating supply voltage range : $V_{CC(opr)} = 0.9V \sim 2.2V$ ($T_a = 25^\circ C$)

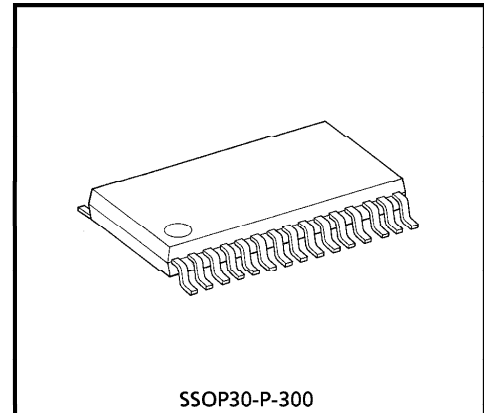

SSOP30-P-300
Weight : 0.17g (Typ.)

BLOCK DIAGRAM

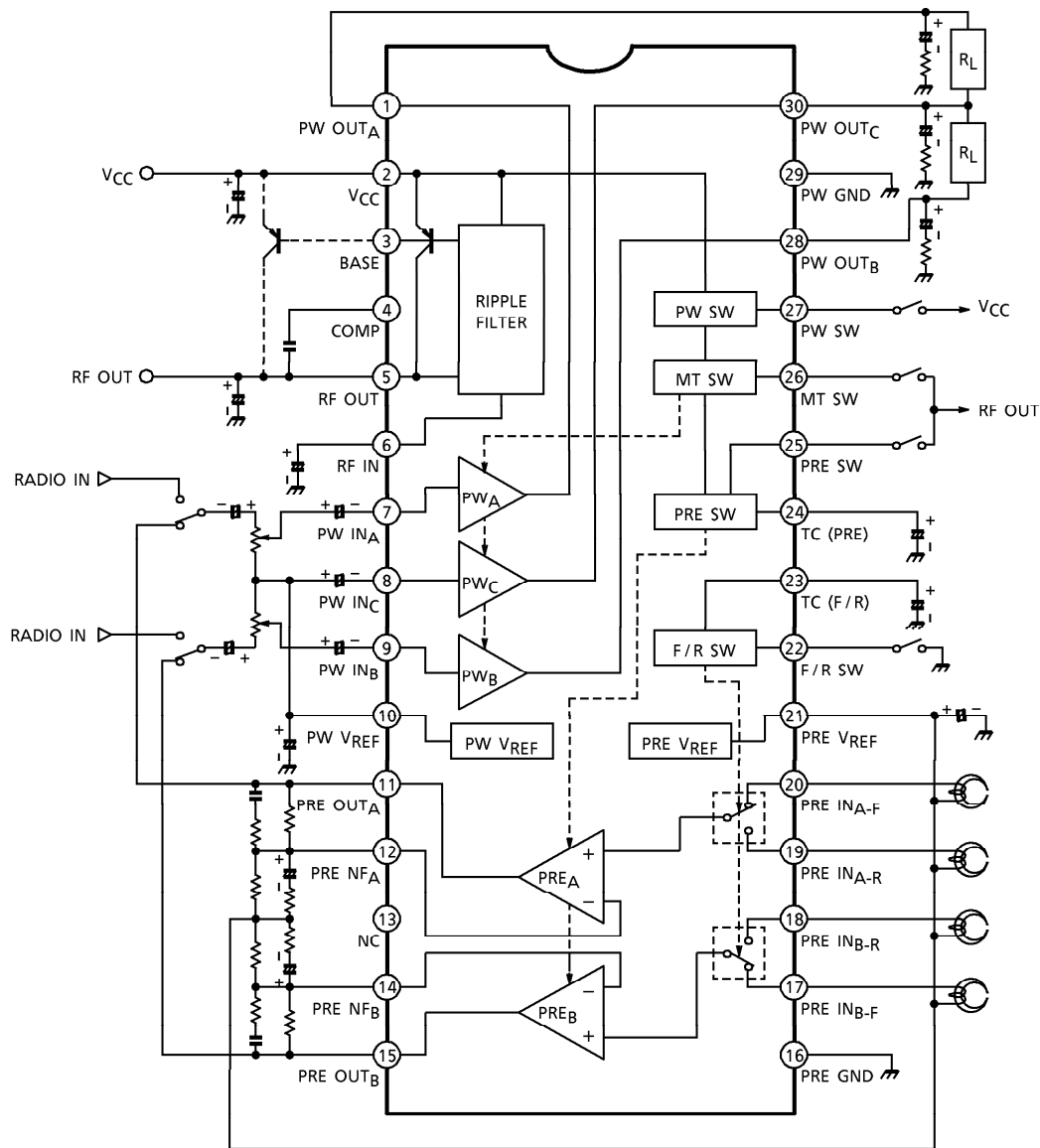

TERMINAL EXPLANATION

Terminal voltage : Typical terminal voltage at no signal with test circuit. ($V_{CC} = 1.2V$, $T_a = 25^\circ C$)

TERMINAL		FUNCTION	INTERNAL CIRCUIT	TERMINAL VOLTAGE (V)	
No.	NAME				
1	PW OUT _A	Output of power amplifier.		0.6	
28	PW OUT _B			0.6	
30	PW OUT _C	Output of common power amplifier.		0.6	
7	PW IN _A	Input of power amplifier.		0.75	
9	PW IN _B			0.75	
8	PW IN _C	Input of common power amplifier.		0.75	
2	V _{CC}	—			1.2
3	BASE	Base bias of an external PNP transistor for ripple filter.			0.5
4	COMP	Phase compensation of ripple filter circuit.			0.5
5	RF OUT	Ripple filter output. Ripple filter circuit supplies V _{REF} circuit, Pre-amplifier circuit, and F/R switch circuit with power source.			1.13
6	RF IN	Ripple filter terminal.	1.13		
10	PW V _{REF}	Reference voltage of power amplifier.		0.75	

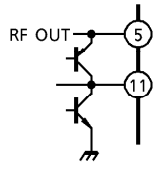
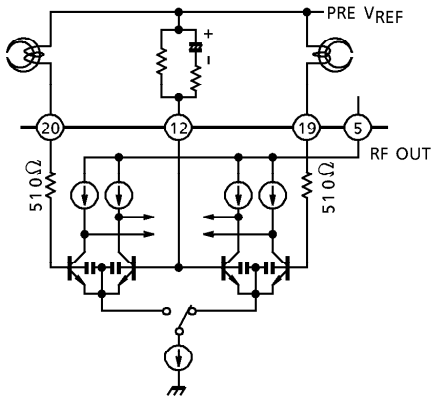
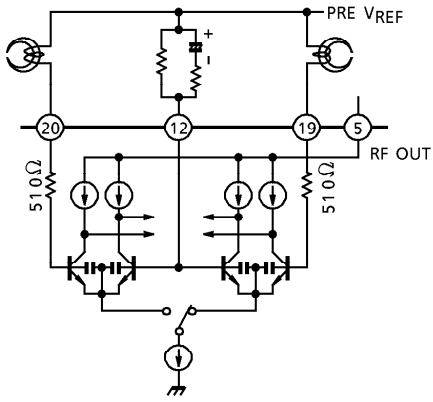
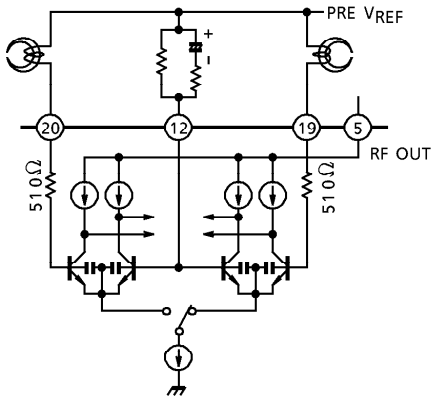
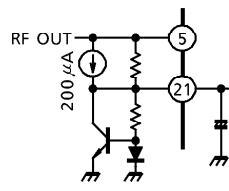
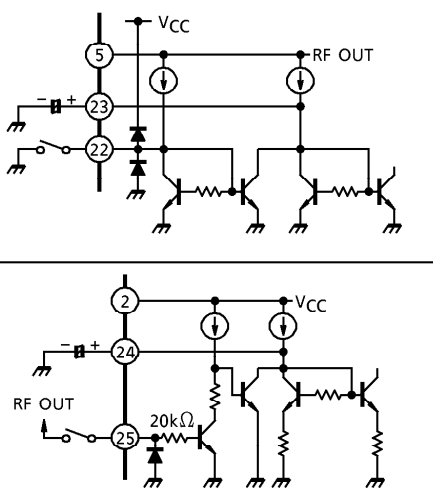
TERMINAL		FUNCTION	INTERNAL CIRCUIT	TERMINAL VOLTAGE (V)
No.	NAME			
11	PRE OUT _A	Output of pre-amplifier.		0.5
15	PRE OUT _B			
12	PRE NF _A	NF of pre-amplifier.		0.75
14	PRE NF _B			
17	PRE IN _{B-F}	Forward input of pre-amplifier. (at F/R SW : open)		0.75
20	PRE IN _{A-F}			
18	PRE IN _{B-R}	Reverse input of pre-amplifier. (at F/R SW : GND)		0.75
19	PRE IN _{A-R}			
13	NC	—	—	—
16	PRE GND	—	—	0
21	PRE V _{REF}	Reference voltage of pre-amplifier.		0.75
22	F/R SW	Forward / Reverse mode switch. (OPEN : Forward mode) (GND : Reverse mode)		—
23	TC (F/R)	Smoothing terminal. In order to reduce a pop noise at F/R switching.		0.7
24	TC (PRE)	Smoothing terminal. In order to reduce a pop noise at Pre-amplifier ON/OFF switching.		0.7
25	PRE SW	Pre-amplifier ON/OFF switch. (RF OUT : ON) (GND/OPEN : OFF)	—	

TERMINAL		FUNCTION	INTERNAL CIRCUIT	TERMINAL VOLTAGE (V)
No.	NAME			
26	MT SW	Muting switch for power amplifier. (RF OUT : MUTE OFF) (GND/OPEN : MUTE ON)		—
27	PW SW	Power ON/OFF switch. (VCC : ON) (GND/OPEN : OFF)		—
29	PW GND	—	—	0

MAXIMUM RATINGS (Ta = 25°C)

CHARACTERISTIC	SYMBOL	RATING	UNIT
Supply Voltage	V _{CC}	3	V
Output Current	Power	I _o (peak)	60
	Ripple Filter	I _{RF}	5
Power Dissipation (Note)	P _D	550	mW
Operating Temperature	T _{opr}	-25~75	°C
Storage Temperature	T _{stg}	-55~150	°C

(Note) : Derated above Ta = 25°C in the proportion of 4.4mW/°C.

ELECTRICAL CHARACTERISTICS

Unless otherwise specified : V_{CC} = 1.2V, f = 1kHz, Ta = 25°C, SW₁ : a, SW₂ : a, SW₃ : a, SW₇ : on
 Power-amplifier stage : R_g = 600Ω, R_L = 16Ω, SW₃ : b, SW₆ : a
 Pre-amplifier stage : R_g = 2.2kΩ, R_L = 10kΩ, SW₂ : b, SW₅ : a

CHARACTERISTIC	SYMBOL	TEST CIRCUIT	TEST CONDITION	MIN.	TYP.	MAX.	UNIT	
Quiescent Current	I _{CCQ1}	1	POWER OFF, SW ₁ : b, SW ₂ : b	—	0.1	5	μA	
	I _{CCQ2}		POWER Amp. OFF, SW ₂ : b	—	2.8	4.5	mA	
	I _{CCQ3}		V _{in} = 0	—	13	16		
Power-amplifier Stage	Voltage Gain	G _V	V _O = -22dBV	26	28	30	dB	
	Channel Balance			CB	—	0		1.5
	Output Power	P _O	2	V _{CC} = 1.5V, V _{in} (A) = V _{in} (B) THD = 10%	5	6	—	mW
	Total Harmonic Distortion	THD ₁		V _{CC} = 1V, P _O (A) = P _O (B) = 1mW	—	0.4	1.5	%
	Output Noise Voltage	V _{no}		BPF : 20Hz~20kHz, SW ₆ : b	—	48	70	μV _{rms}

CHARACTERISTIC		SYMBOL	TEST CIRCUIT	TEST CONDITION	MIN.	TYP.	MAX.	UNIT
Power-amplifier Stage	Ripple Rejection Ratio	RR ₁	2	V _{CC} = 1V, f _r = 100Hz, V _r = -32dBV I _{RF} = 0, SW ₆ : b, SW ₇ : open	45	54	—	dB
	Cross Talk (CH-A / CH-B)	CT ₁		V _O = -22dBV	30	38	—	
	Power Muting Attenuation	ATT ₁		V _O = -22dBV, SW ₂ : a→b	70	83	—	
Ripple Filter Stage	Output Voltage	V _{RF}	2	V _{CC} = 1V, I _{RF} = 0	0.88	0.92	—	V
	Ripple Rejection Ratio	RR ₂		V _{CC} = 1V, f _r = 100Hz, V _r = -32dBV I _{RF} = 30mA, SW ₇ : open	38	45	—	dB
Pre-amplifier Stage	Open Loop Voltage Gain	G _{VO}	2	V _O = -22dBV, SW ₅ : b	63	70	—	dB
	Closed Loop Voltage Gain	G _{VC}		V _O = -22dBV	—	34	—	
	Maximum Output Voltage	V _{om}		THD = 1%	160	290	—	mV _{rms}
	Total Harmonic Distortion	THD ₂		V _{CC} = 1V, V _O = 100mV _{rms}	—	0.06	0.3	%
	Equivalent Input Noise Voltage	V _{ni}		BPF : 20Hz~20kHz, SW ₈ : open NAB (f = 1kHz, G _V = 34dB)	—	1.7	2.7	μV _{rms}
	Cross Talk (CH-A / CH-B)	CT ₂		V _O = -22dBV	—	61	—	dB
	Cross Talk (Forward / Reverse)	CT ₃			—	61	—	
Pre Muting Attenuation	ATT ₂	V _O = -22dBV, SW ₃ : a→b	—	75	—			
Power ON Current	I ₂₇	1	V _{CC} = 0.9V	V ₁₀ ≥ 0.5V, SW ₁ : c	5	—	—	μA
Power OFF Voltage	V ₂₇			V ₁₀ ≤ 0.3V, SW ₁ : d	0	—	0.3	V
Power Amp. Mute OFF Current	I ₂₆			V ₃₀ ≥ 0.4V, SW ₂ : c	5	—	—	μA
Power Amp. Mute ON Voltage	V ₂₆			V ₃₀ ≤ 0.3V, SW ₂ : d	0	—	0.3	V
Pre. Amp. ON Current	I ₂₅			V ₂₄ ≥ 0.5V, SW ₃ : c	5	—	—	μA
Pre. Amp. OFF Voltage	V ₂₅			V ₂₄ ≤ 0.3V, SW ₃ : d	0	—	0.3	V
Reverse Mode Voltage	V ₂₂			V ₂₃ ≥ 0.5V, SW ₄ : c	0	—	0.3	V

TEST CIRCUIT 1

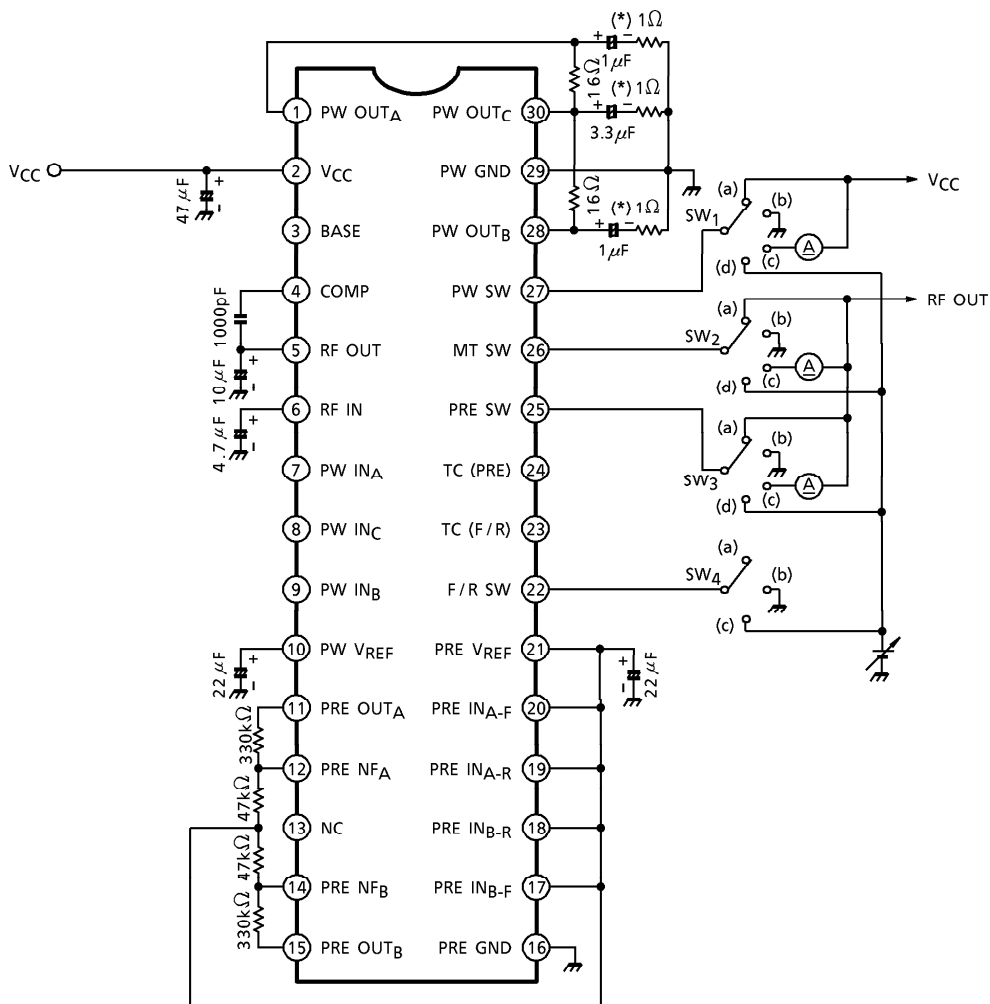

(*) Tantal Condenser

TEST CIRCUIT 2

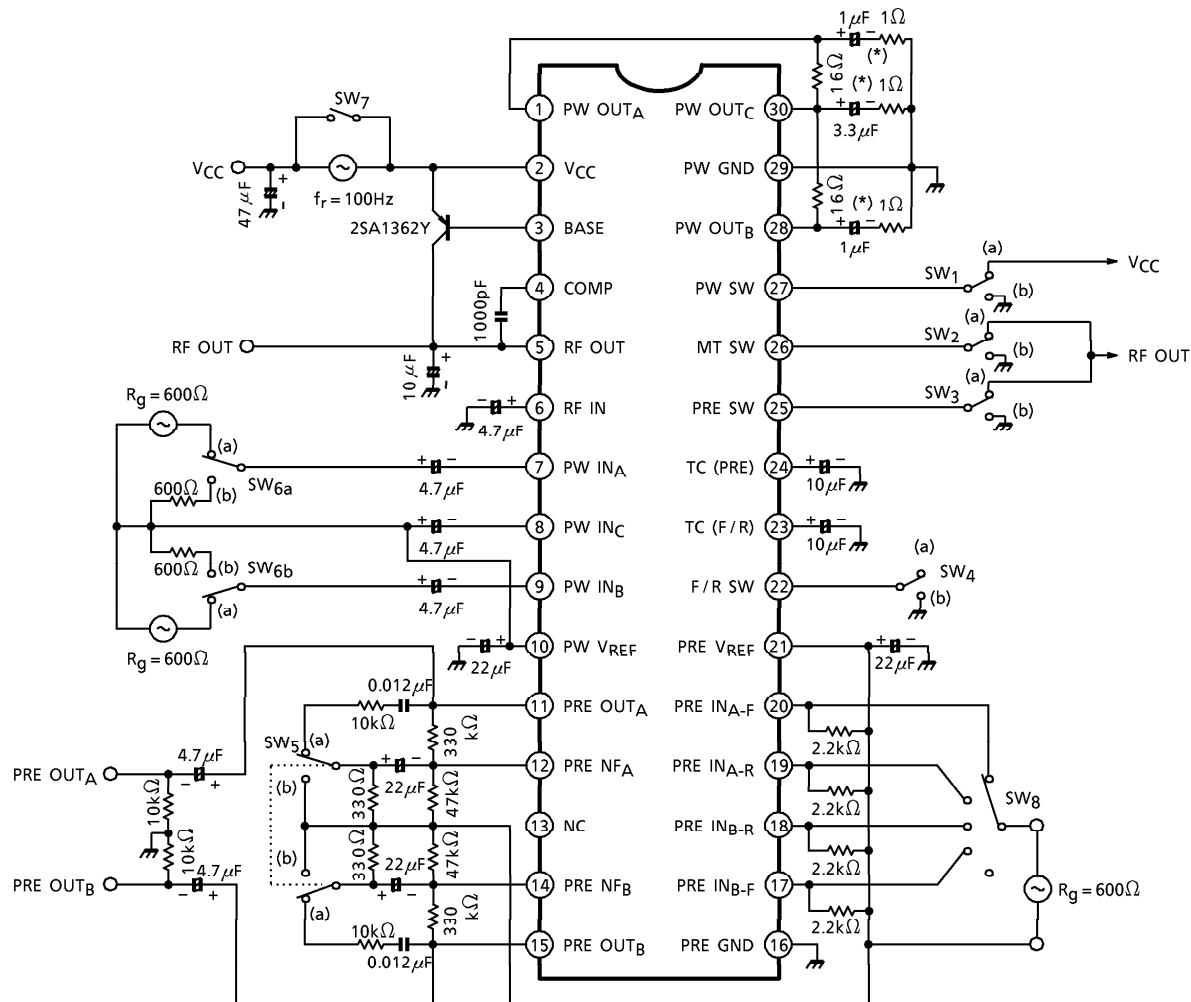

(*) Tantal Condenser

CHARACTERISTIC CURVES Unless otherwise specified : $V_{CC} = 1.2V$, $T_a = 25^\circ C$, $f = 1kHz$
 Pre-Amplifier Stage : $R_g = 2.2k\Omega$, $R_L = 10k\Omega$
 Power Amplifier Stage : $R_g = 600\Omega$, $R_L = 16\Omega$

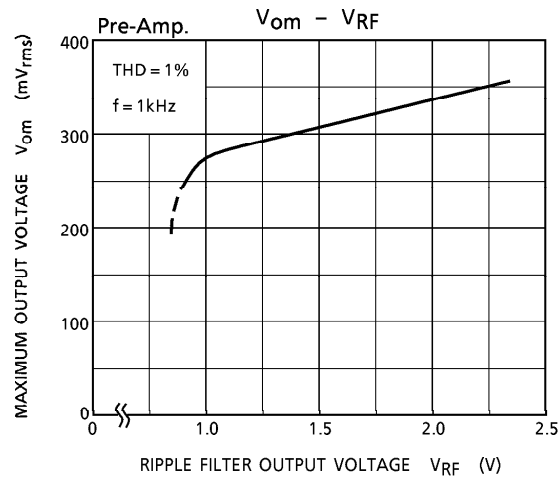
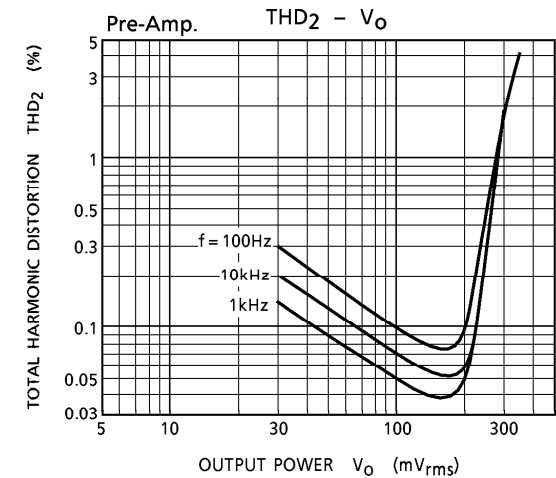
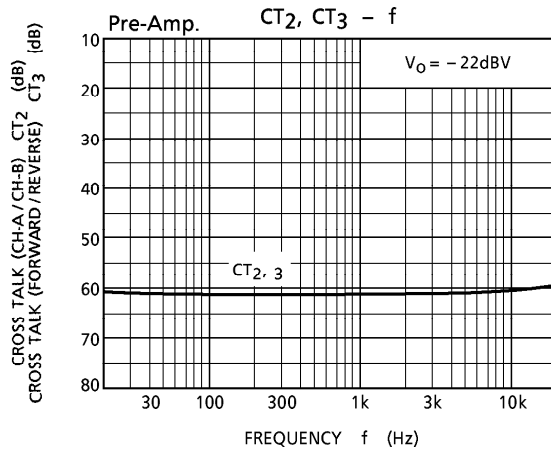
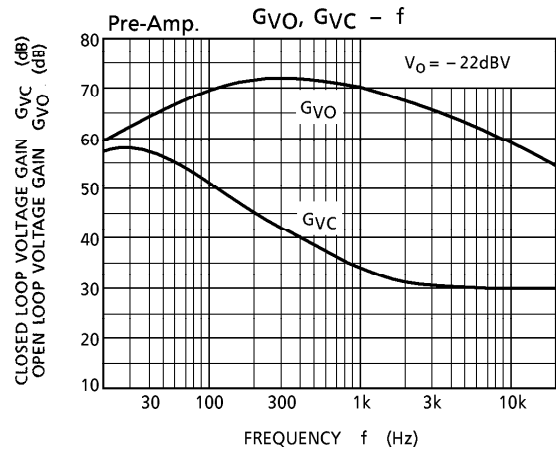
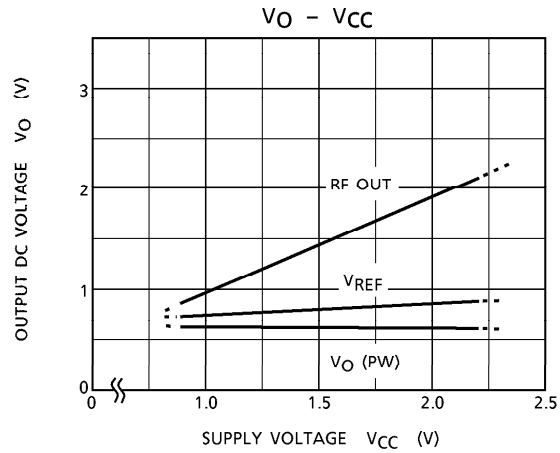
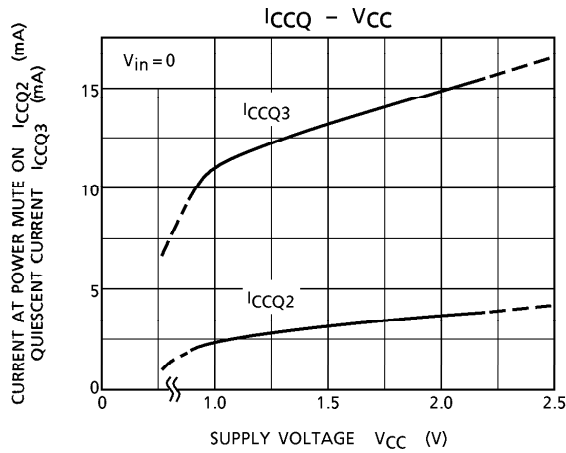

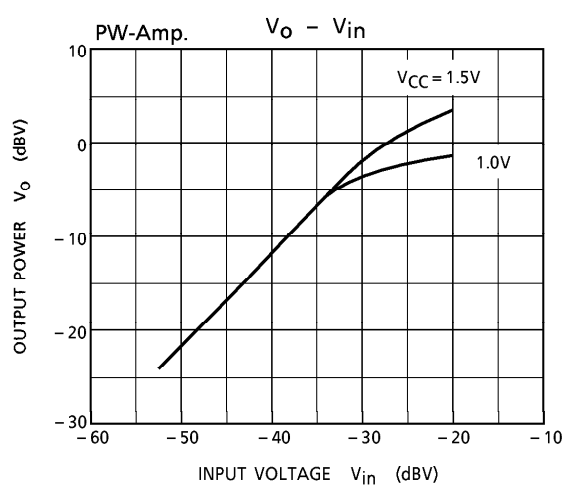
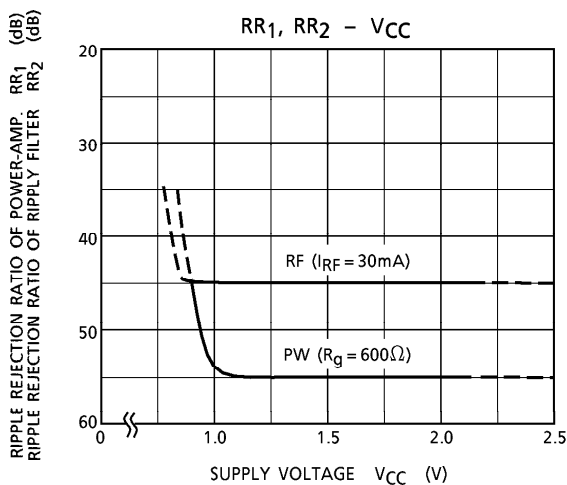
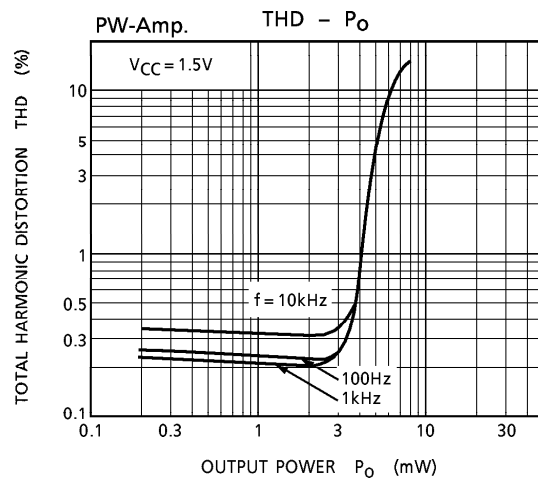
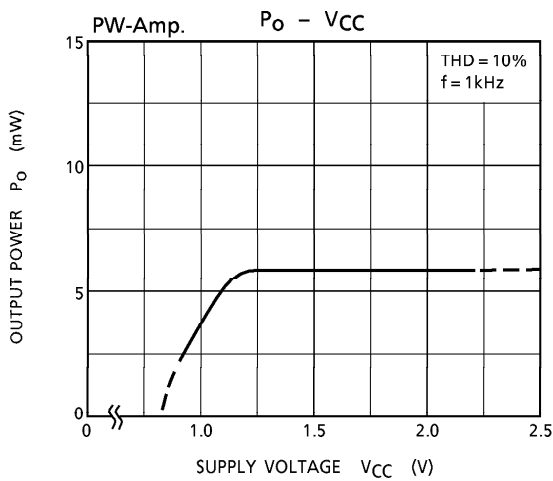
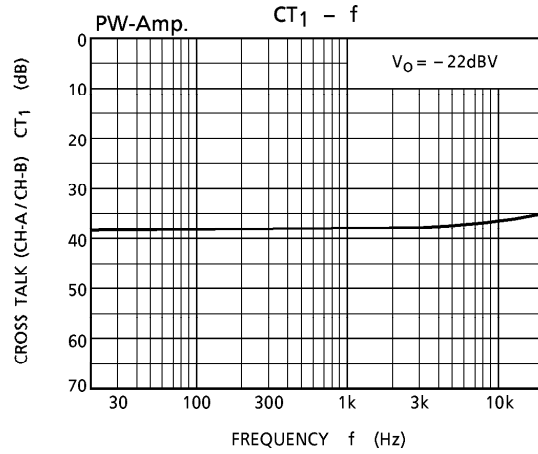
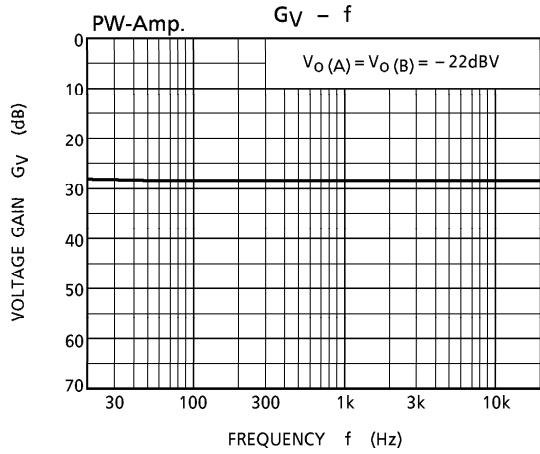

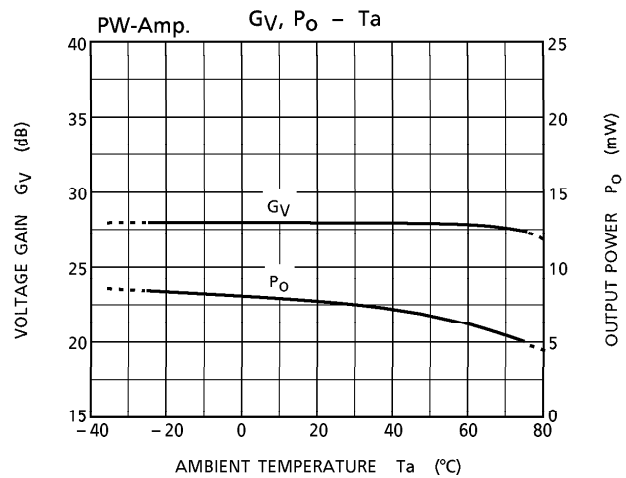
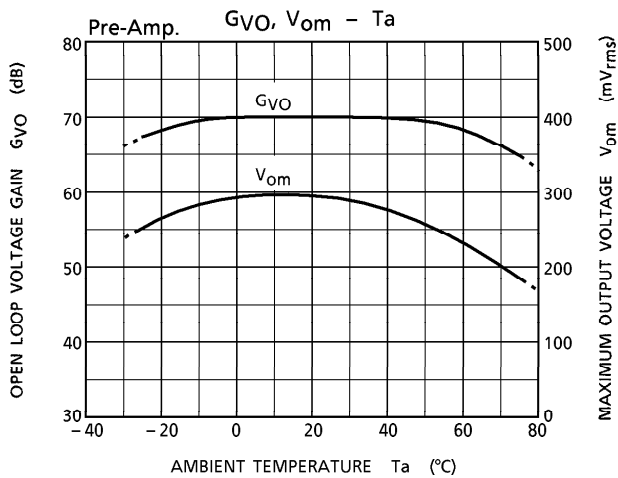
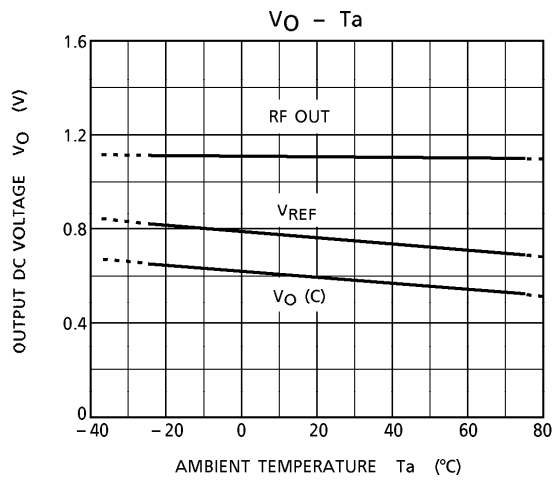
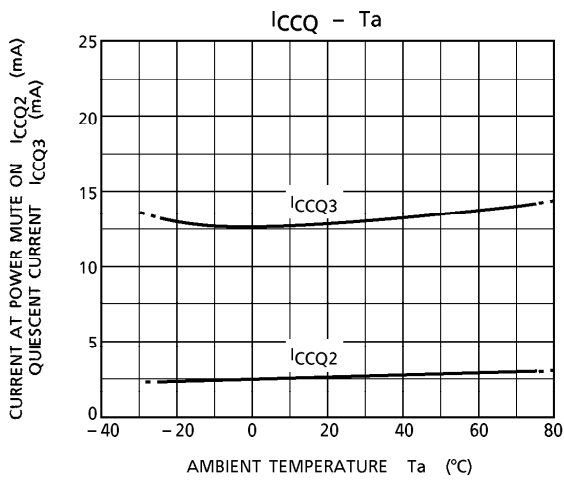
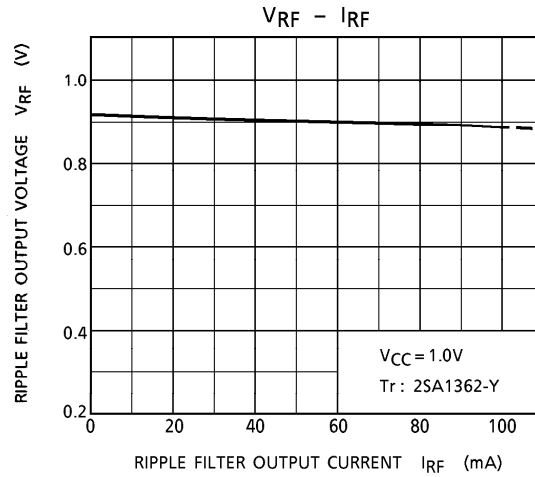
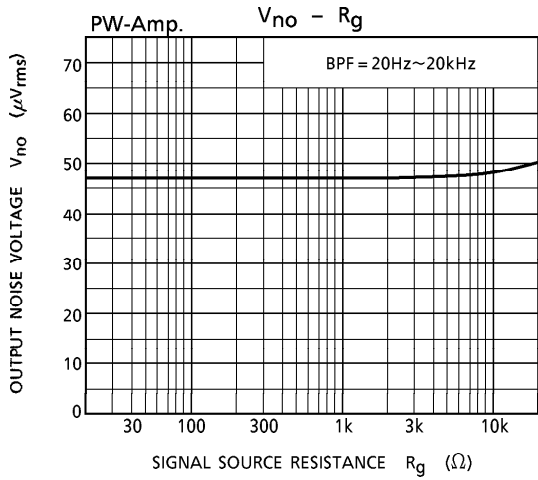

OUTLINE DRAWING
SSOP30-P-300

Unit : mm

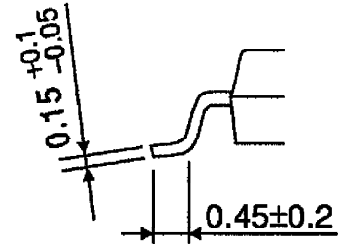
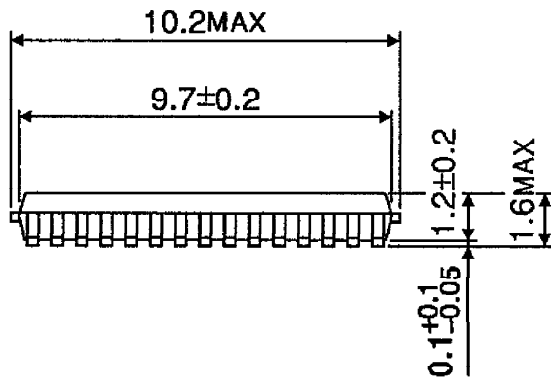
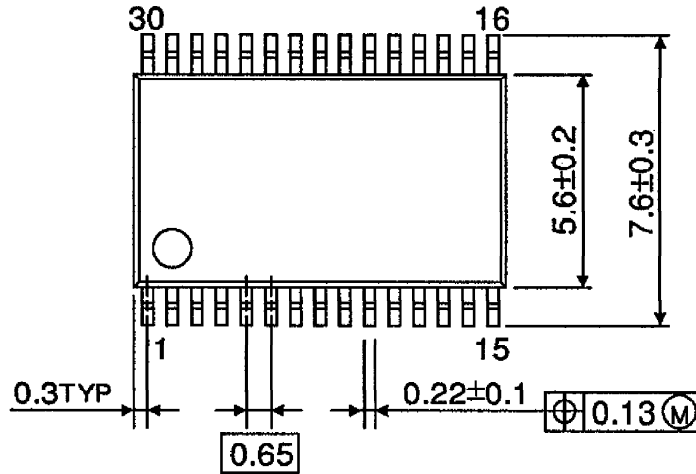

Weight : 0.17g (Typ.)