

# TA8061H

## DUAL HIGHSIDE DRIVER WITH DIAGNOSIS

The TA8061H is a 1.5A highside driver containing two circuits. Each circuit has a self-diagnostic function which produces a diagnostic output. The input is TTL-compatible.

This IC has other various protective functions.

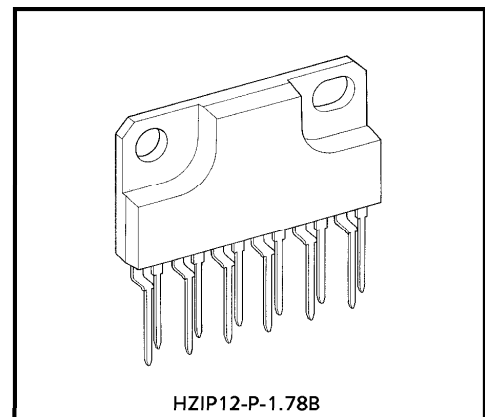

Weight : 4.0g (Typ.)

### FEATURES

- Output current capacity : 1.5A
- Diagnostic function : Load-open (10mA or less) and over-current (3A or more) detection
- Protective function : Short-circuit protection (latch) and thermal-shutdown / over-voltage protection (nonlatch)
- Low standby current : 0.5mA (Max.)
- Two circuits contained
- Power package HZIP-12pin

### BLOCK DIAGRAM AND PIN LAYOUT

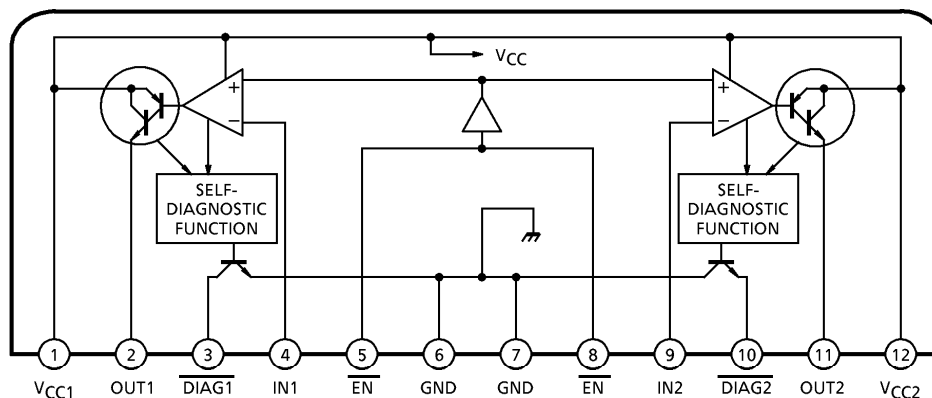

961001EBA2

- TOSHIBA is continually working to improve the quality and the reliability of its products. Nevertheless, semiconductor devices in general can malfunction or fail due to their inherent electrical sensitivity and vulnerability to physical stress. It is the responsibility of the buyer, when utilizing TOSHIBA products, to observe standards of safety, and to avoid situations in which a malfunction or failure of a TOSHIBA product could cause loss of human life, bodily injury or damage to property. In developing your designs, please ensure that TOSHIBA products are used within specified operating ranges as set forth in the most recent products specifications. Also, please keep in mind the precautions and conditions set forth in the TOSHIBA Semiconductor Reliability Handbook.
- The products described in this document are subject to foreign exchange and foreign trade control laws.
- The information contained herein is presented only as a guide for the applications of our products. No responsibility is assumed by TOSHIBA CORPORATION for any infringements of intellectual property or other rights of the third parties which may result from its use. No license is granted by implication or otherwise under any intellectual property or other rights of TOSHIBA CORPORATION or others.
- The information contained herein is subject to change without notice.

**PIN DESCRIPTION**

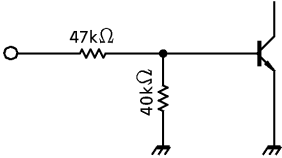
PIN No.	SYMBOL	DESCRIPTION
1, 12	V <sub>CC</sub>	Power supply pin. A function for protection against over-voltage is provided so that the output will turn off when the applied voltage exceeds 27.5V (Typ.). This function works to protect the IC and load.
2, 11	OUT	PNP-type complementary output pin with a current capacity of 1.5A. When the output pin is supplied with a current exceeding the detection current (typically 3A) because of load short-circuit, the output is latched to the OFF state to protect the IC. To restart, turn off the input once, then raise it high.
3, 10	$\overline{\text{DIAG}}$	Self-diagnosis detection pin. This signal goes low when the output is short-circuited or opened while the input is on (high). The output will be latched when the load is short-circuited, but will not when the load is opened. This pin supplies an NPN open-collector output.
4, 9	IN	TTL-compatible input pin. The circuit is shown as follows. 
5, 8	$\overline{\text{EN}}$	When this signal goes high, both channels 1 and 2 are placed in standby state (0.5mA Max.).
6, 7	GND	Grounded.

**TRUTH TABLE**

IN	OUT		$\overline{\text{DIAG}}$
H	H (ON)	Normal	H
		Abnormal	L
L	L (OFF)	—	H

**TIMING CHART**

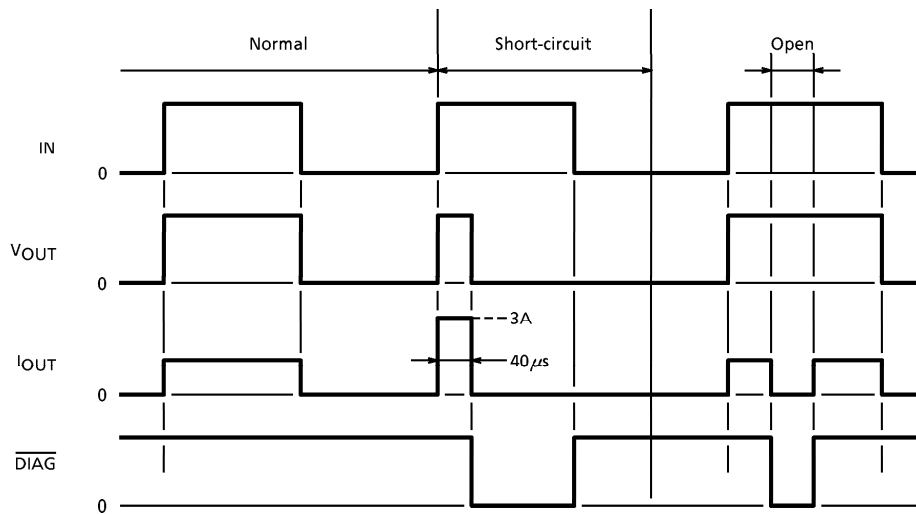

**MAXIMUM RATINGS (Ta = 25°C)**

CHARACTERISTIC	SYMBOL	RATING	UNIT
Power Supply Voltage	V <sub>CC</sub>	30	V
	V <sub>CC</sub>	60 (1s)	
Input Voltage	V <sub>IN</sub>	18	V
Output Voltage	V <sub>OUT</sub>	-0.3~V <sub>CC</sub>	V
Output Current	I <sub>OUT</sub>	-1.5	A
Power Dissipation	P <sub>D</sub>	25	W
Operating Temperature	T <sub>opr</sub>	-40~110	°C
Storage Temperature	T <sub>stg</sub>	-55~150	°C
Lead Temperature-time	T <sub>sol</sub>	260 (10s)	°C

ELECTRICAL CHARACTERISTICS ( $V_{CC} = 12V$ ,  $T_a = 25^\circ C$ )

CHARACTERISTIC	SYMBOL	PIN	TEST CIRCUIT	TEST CONDITION	MIN.	TYP.	MAX.	UNIT
Power Supply Current	$I_{CC}$	$V_{CC1, 2}$	—	In standby state	—	—	0.5	mA
			—	$\overline{EN} = "L"$ IN = "L"	—	4	8	
			—	CH1 or CH2 = ON	—	20	40	
			—	CH1, CH2 = ON	—	35	60	
Input Voltage	$V_{IH}$	IN1, 2	—	—	2	—	—	V
	$V_{IL}$		—	—	-0.3	—	0.8	
Input Current	$I_{IH}$	IN1, 2	—	$V_{IN} = 3V$	—	—	0.12	mA
	$I_{IL}$		—	$V_{IN} = 0.8V$	—	—	0.03	
Output Voltage	$V_{OH}$	OUT1, 2	—	$I_{OUT} = 1A$	—	1.2	1.5	V
	$V_{OL}$	DIAG1, 2	—	$I_{OUT} = 3mA$	—	0.2	0.5	
Output Leakage Current	$I_{LEAK}$	OUT1, 2	—	$V_{OUT} = 0V$	—	—	10	$\mu A$
		DIAG1, 2	—	$V_{OUT} = 5V$	—	—	10	
Over-current Detection	$I_{SD1}$	OUT1, 2	—	—	—	3.0	—	A
Load-Open Detection	$I_{SD2}$	OUT1, 2	—	—	—	25	—	mA
Over-voltage Detection	$V_{SD}$	$V_{CC1, 2}$	—	—	—	27.5	—	V
Shutdown Temperature	$T_{SD}$	—	—	—	—	150	—	$^\circ C$
Transfer Delay Time	$t_{pLH}$	OUT1, 2	—	$I_{OUT} = 1A$	—	1	—	$\mu s$
	$t_{pHL}$				—	5	—	

**OUTLINE DRAWING**  
HZIP12-P-1.78B

Unit : mm

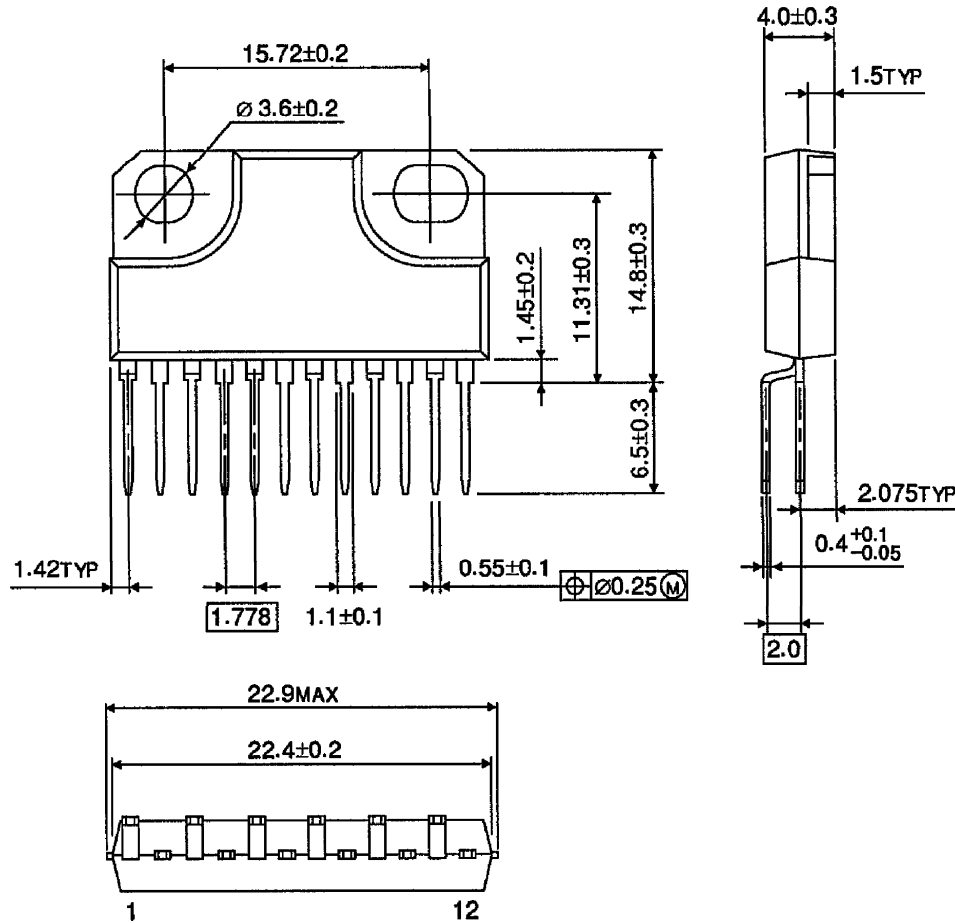

Weight : 4.0g (Typ.)