

# TA8029S

## FREQUENCY TO VOLTAGE CONVERTER

The TA8029S is a small 9-pin SIP IC incorporating an accurate frequency / voltage converter and two voltage comparators. It has a Schmitt input circuit and becomes active on the positive edge of the input. Its F / V output is stable even when it is supplied with a high-frequency input. Since the VCC pin connects to a shunt regulator, stable frequency detection is assured regardless of the battery voltage. In addition, its wide operating temperature range allows it to be used for a wide variety of applications.

### FEATURES

- Schmitt input circuit incorporated
- Stable F / V output in response to high-frequency input
- Two comparators served by single power supplies are incorporated.
- Shunt regulator incorporated
- Operating temperature range : from  $-40\sim 85^{\circ}\text{C}$
- Small plastic SIP-9 pin

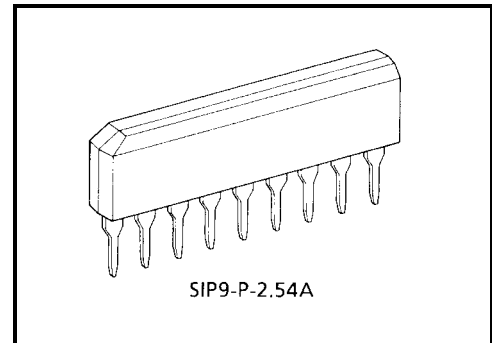

Weight: 0.92 g (typ.)

### BLOCK DIAGRAM AND PIN LAYOUT

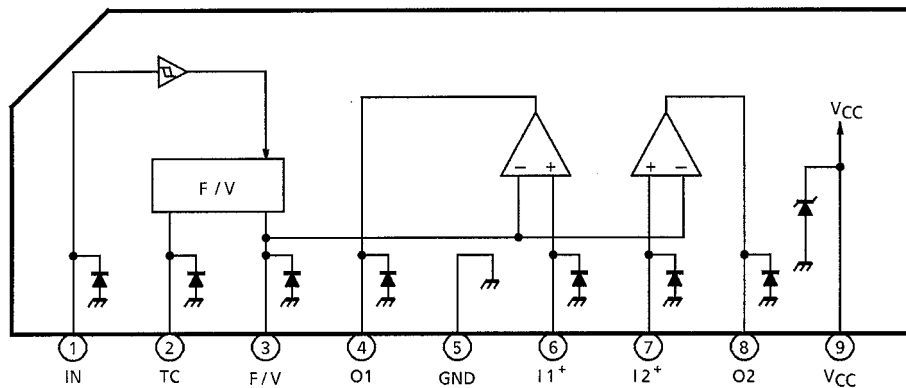

## PIN DESCRIPTION

PIN No.	SYMBOL	DESCRIPTION
1	IN	Frequency input pin. The IC becomes active on the leading edge of the input.
2	TC	One-shot pulse setting pin which connects to a capacitor.
3	F / V	F / V conversion output pin which connects to an charging capacitor and resistor. The signal from this pin is also the input to the two built-in comparator.
4	O1	Comparator 1 output pin. This pin provides an NPN transistor open-collector output and has a current capacity of up to 30mA.
5	GND	Grounded
6	$I_1^+$	Non-inverted PNP input pin for comparator 1.
7	$I_2^+$	Non-inverted PNP input pin for comparator 2.
8	O2	Comparator 2 output pin. This pin provides an NPN transistor open-collector output and has a current capacity of up to 30mA.
9	$V_{CC}$	Power supply pin which connects to a 6V Zener diode.

## TIMING CHART

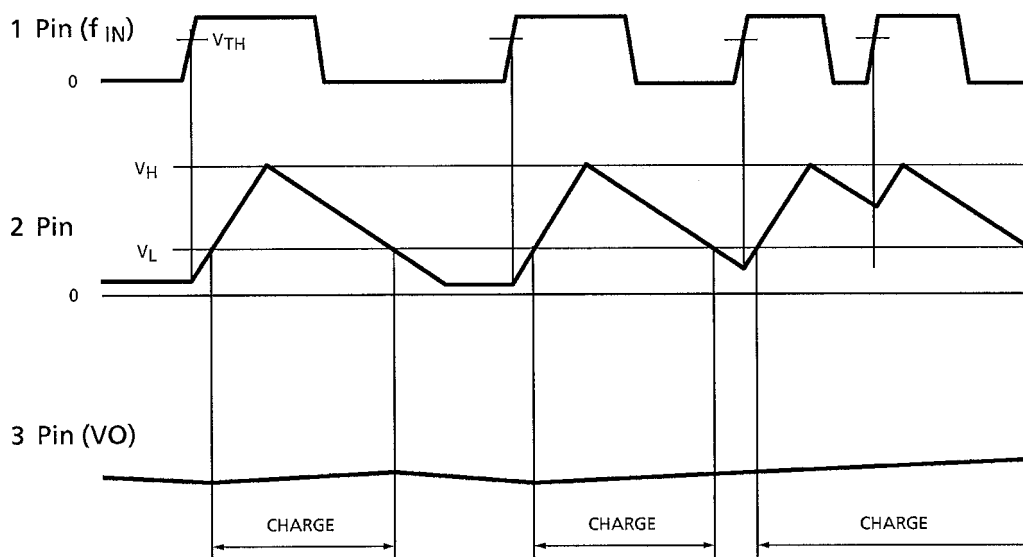

## MAXIMUM RATINGS (Ta = 25°C)

CHARACTERISTIC	SYMBOL	RATING	UNIT
Supply Current	I <sub>CC</sub>	30	mA
Input Voltage	V <sub>IN</sub>	-0.3~30	V
Output Voltage	V <sub>OUT</sub>	-0.3~30	V
Output Current	I <sub>OUT</sub>	30	mA
Power Dissipation	P <sub>D</sub>	350 (Note)	mW
Operating Temperature	T <sub>opr</sub>	-40~85	°C
Storage Temperature	T <sub>stg</sub>	-55~150	°C

Note: Ta ≤ 85°C

## ELECTRICAL CHARACTERISTICS (Ta = 25°C, V<sub>CC</sub> = 5V)

CHARACTERISTIC	SYMBOL	PIN	TEST CIRCUIT	TEST CONDITION	MIN	TYP.	MAX	UNIT
Current Consumption	I <sub>CC</sub>	V <sub>CC</sub>	—		—	3.0	5	mA
Regulated Voltage	V <sub>R</sub>	V <sub>CC</sub>	—	I <sub>CC</sub> = 12mA	5.5	6.0	6.5	V
Input Current	I <sub>IN</sub>	IN	—	V <sub>IN</sub> = 0~20V	-10	—	10	μA
Input Voltage	V <sub>IH</sub>	IN	—		2.8	—	—	V
	V <sub>IL</sub>		—		—	—	0.8	
Input Rise Rate	V <sub>LH</sub>	IN	—		0.5	—	—	V / ms
Input Fall Rate	V <sub>HL</sub>	IN	—		0.1	—	—	V / ms
Output Current	I <sub>OL</sub>	TC	—	V <sub>TC</sub> = 2.5V	—	43	—	μA
	I <sub>OH</sub>		—	V <sub>TC</sub> = 2.5V	—	-73	—	
	I <sub>OH</sub>	F / V	—		-250	-350	-500	
F / V Conversion Coefficient	K	F / V	—	C <sub>T</sub> = 0.01μF, R <sub>T</sub> = 27kΩ f = 100Hz (Note 1)	—	7.8	—	—
Linearity			—	C <sub>T</sub> = 0.01μF, R <sub>T</sub> = 27kΩ (Note 2)	—	±3.0	—	%
Input Offset Voltage	V <sub>IO</sub>	I <sub>1</sub> <sup>+</sup> / I <sub>2</sub> <sup>+</sup>	—		—	2	10	mV
Input Current	I <sub>IN</sub>	I <sub>1</sub> <sup>+</sup> / I <sub>2</sub> <sup>+</sup>	—		—	-0.2	-1	μA
Common-mode Input Voltage	V <sub>CM</sub>	I <sub>1</sub> <sup>+</sup> / I <sub>2</sub> <sup>+</sup>	—		0	—	V <sub>CC</sub> -1.5	V
Voltage Gain	A <sub>V</sub>		—		—	100	—	dB
Output Voltage	V <sub>OL</sub>	O <sub>1</sub> / O <sub>2</sub>	—	I <sub>OL</sub> = 10mA	—	—	0.5	V
Output Leakage Current	I <sub>LEAK</sub>	O <sub>1</sub> / O <sub>2</sub>	—	V <sub>O</sub> = 16V	—	—	5	μA

Notes:

1. Calculated from  $V_O = K \cdot V_{CC} \cdot C_T \cdot R_T \cdot f$
2. Straight line deviation at f = 50Hz and f = 150Hz relative to that at f = 100Hz

**STANDARD CHARACTERISTICS**

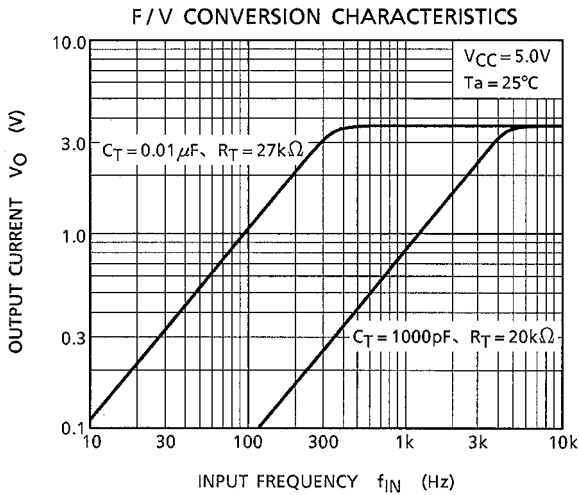

**EXAMPLE OF APPLICATION CIRCUIT**

**1. FREQUENCY-VOLTAGE CONVERSION CIRCUIT**

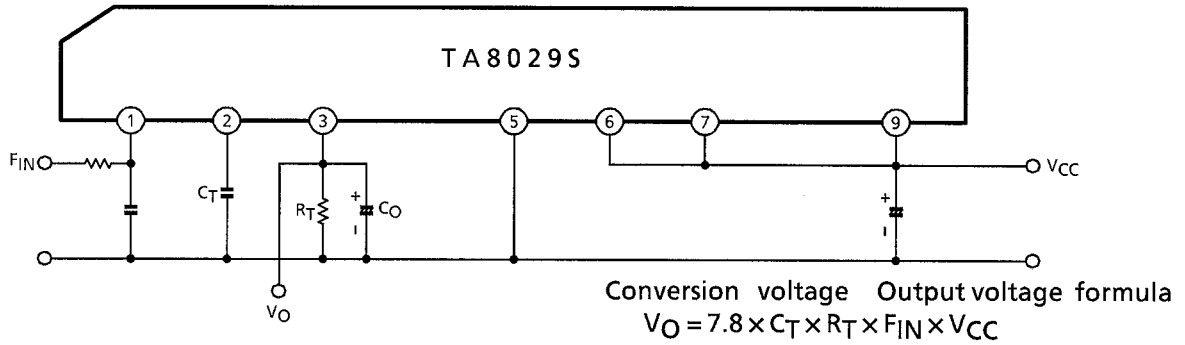

**2. FREQUENCY DETECTION CIRCUIT**

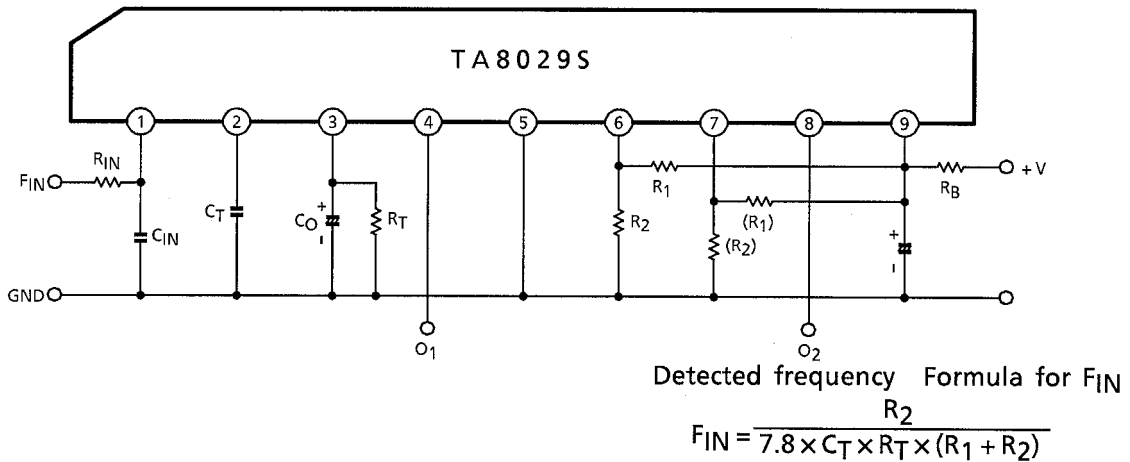

**RECOMMENDED CONDITION**

PART NAME	MIN	MAX	UNIT
$C_T$	1000		pF
$R_T$	20		k $\Omega$
$f_{IN}$		5	kHz

## PACKAGE DIMENSIONS

SIP9-P-2.54A

Unit : mm

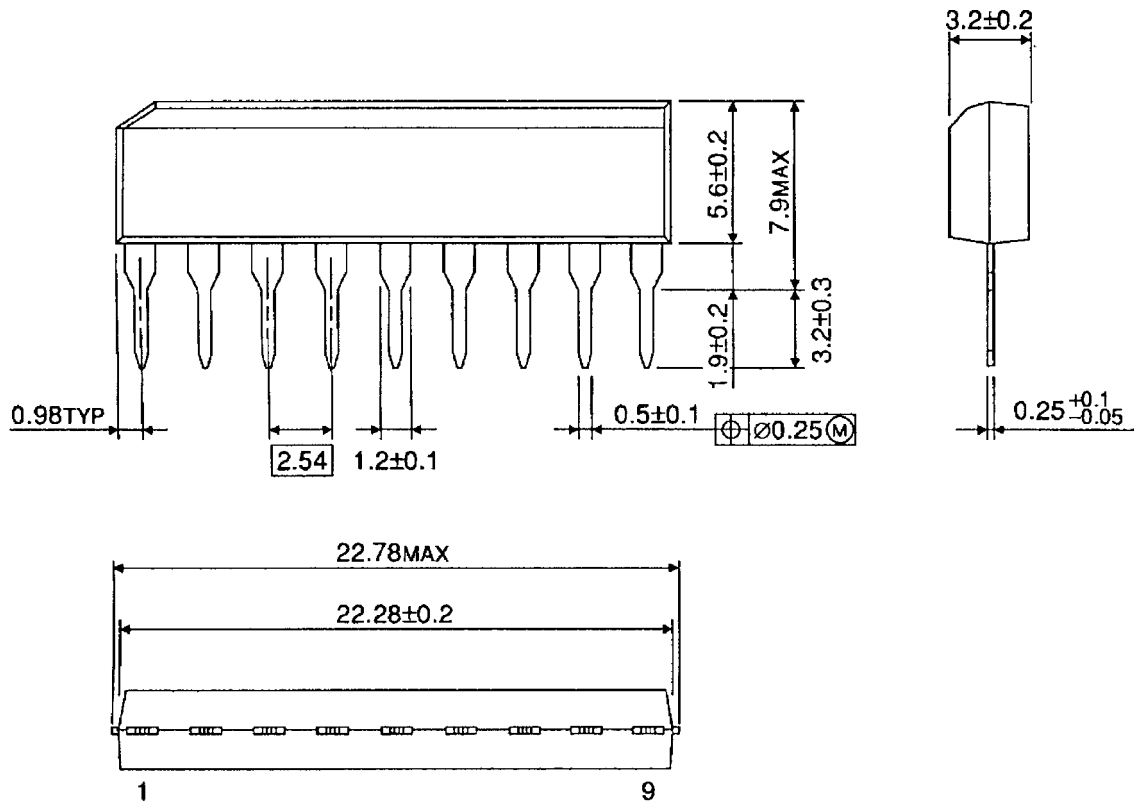

Weight: 0.92g (Typ.)

**RESTRICTIONS ON PRODUCT USE**

000707EAA\_S

- TOSHIBA is continually working to improve the quality and reliability of its products. Nevertheless, semiconductor devices in general can malfunction or fail due to their inherent electrical sensitivity and vulnerability to physical stress. It is the responsibility of the buyer, when utilizing TOSHIBA products, to comply with the standards of safety in making a safe design for the entire system, and to avoid situations in which a malfunction or failure of such TOSHIBA products could cause loss of human life, bodily injury or damage to property.  
In developing your designs, please ensure that TOSHIBA products are used within specified operating ranges as set forth in the most recent TOSHIBA products specifications. Also, please keep in mind the precautions and conditions set forth in the "Handling Guide for Semiconductor Devices," or "TOSHIBA Semiconductor Reliability Handbook" etc..
- The information contained herein is presented only as a guide for the applications of our products. No responsibility is assumed by TOSHIBA CORPORATION for any infringements of intellectual property or other rights of the third parties which may result from its use. No license is granted by implication or otherwise under any intellectual property or other rights of TOSHIBA CORPORATION or others.
- The information contained herein is subject to change without notice.