

TOSHIBA BIPOLAR LINEAR INTEGRATED CIRCUIT SILICON MONOLITHIC

TA7796P, TA7796Z**5 BAND GRAPHIC EQUALIZER**

TA7796P, TA7796Z are 5-Band graphic equalizer IC, which have 5 resonance circuit and an output buffer amplifier. 5 band graphic equalizer for one channel can be formed easily by externally connecting capacitors and variable resistors which fix f_0 (resonance frequency).

Dual inline package 16pin TA7796P

Zig-Zag inline package 16pin TA7796Z

FEATURES

- Few External Parts
- Low Distortion
: THD = 0.007% (Typ.)
($V_O = 0.245V_{rms}$ (- 10dBm), $f = 1.1kHz$ BW = 20~20kHz, FLAT)
- Low Noise
: $V_{NO} = 3.0\mu V_{rms}$ (Typ.)
($R_g = 620\Omega$, $V_{in} = 0$, BW = 20~20kHz, FLAT)
- Wide Operating Supply Voltage Range
: $V_{CC} = 4.0\sim 16V$ ($T_a = 25^\circ C$)

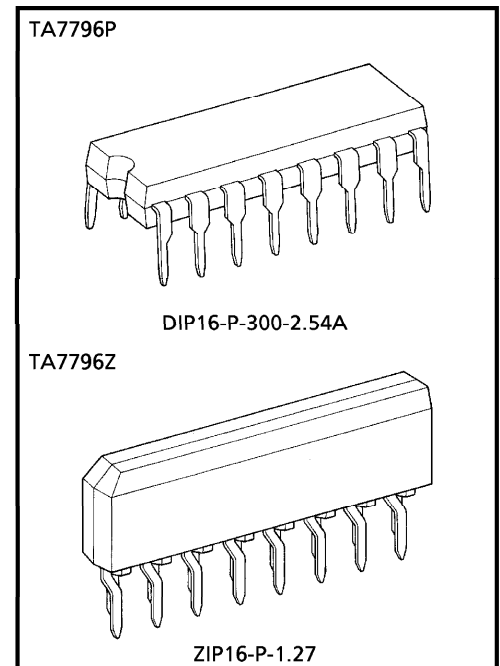
**Weight**

DIP16-P-300-2.54A : 1.0g (Typ.)
ZIP16-P-1.27 : 0.99g (Typ.)

BLOCK DIAGRAM

TA7796P

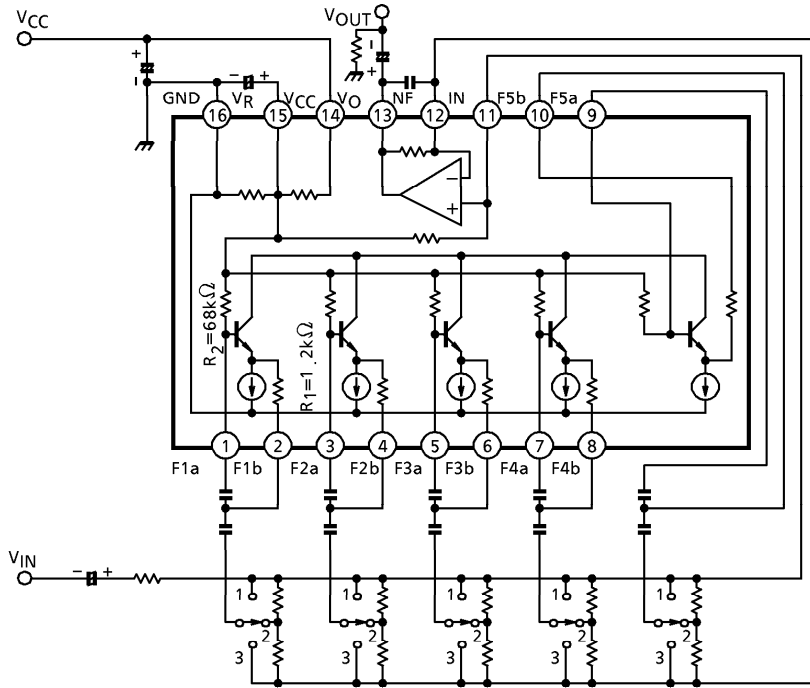

TA7796Z

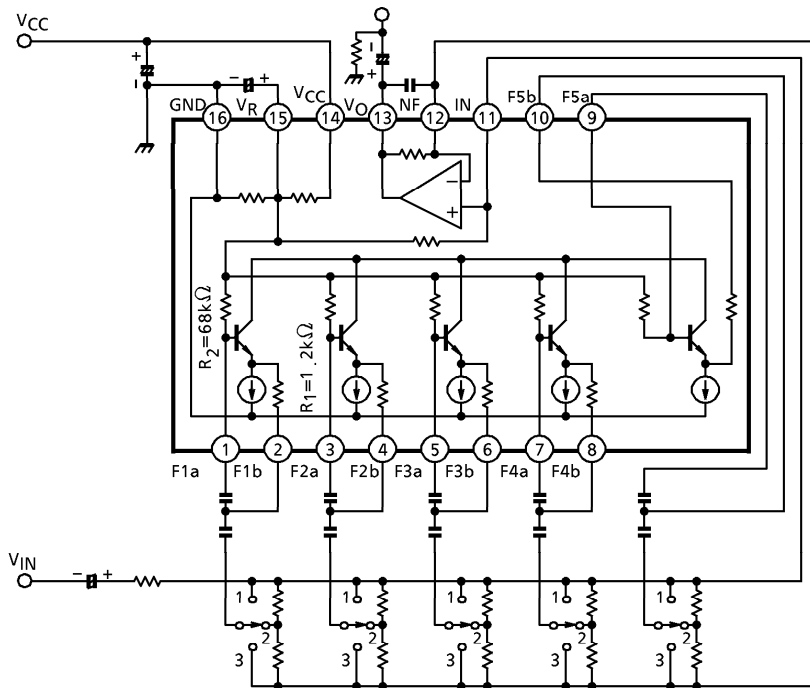

MAXIMUM RATINGS (Ta = 25°C)

CHARACTERISTIC	SYMBOL	RATING	UNIT
Supply Voltage	V _{CC}	16	V
Power Dissipation	P _D (Note)	750	mW
Operating Temperature	T _{opr}	-30~75	°C
Storage Temperature	T _{stg}	-55~150	°C

(Note) Derated above Ta = 25°C in the proportion of 6mW/°C for TA7796P, TA7796Z.

ELECTRICAL CHARACTERISTICS (Unless otherwise specified, V_{CC} = 8V, f = 1.1kHz, R_L = 10Ω, Ta = 25°C)

CHARACTERISTIC	SYMBOL	TEST CIRCUIT	TEST CONDITION	MIN.	TYP.	MAX.	UNIT
Quiescent Current	I _{CCQ}	—	V _{in} = 0	3.5	6.1	9.3	mA
Voltage Gain	G _V (FLT)	—	V _{out} = 0.775V _{rms} (0dBm)	-2.5	-0.5	1.5	dB
		—	V _{out} = 0.775V _{rms} (0dBm), f = 110Hz	10.0	11.5	14.0	
	G _V (BST)	—	V _{out} = 0.775V _{rms} (0dBm), f = 340Hz	10.0	11.5	14.0	
		—	V _{out} = 0.775V _{rms} (0dBm), f = 1.1kHz	10.0	11.5	14.0	
		—	V _{out} = 0.775V _{rms} (0dBm), f = 3.4kHz	10.0	11.5	14.0	
		—	V _{out} = 0.775V _{rms} (0dBm), f = 11kHz	10.0	11.5	14.0	
	G _V (CUT)	—	V _{out} = 0.775V _{rms} (0dBm), f = 110Hz	-14.0	-11.5	-10.0	
		—	V _{out} = 0.775V _{rms} (0dBm), f = 340Hz	-14.0	-11.5	-10.0	
		—	V _{out} = 0.775V _{rms} (0dBm), f = 1.1kHz	-14.0	-11.5	-10.0	
		—	V _{out} = 0.775V _{rms} (0dBm), f = 3.4kHz	-14.0	-11.5	-10.0	
—		V _{out} = 0.775V _{rms} (0dBm), f = 11kHz	-14.0	-11.5	-10.0		
Total Harmonic Distortion	THD (FLT)	—	V _{out} = 0.245V _{rms} (-10dBm)	—	0.007	0.10	%
Output Noise Voltage	V _{no} (FLT)	—	R _g = 620Ω, V _{in} = 0, BW = 20~20kHz	—	3.0	8.0	μV _{rms}

TYP. DC VOLTAGE OF EACH TERMINAL

TA7796P (V_{CC} = 8V, Ta = 25°C)

TERMINAL No.	1	2	3	4	5	6	7	8
DC-VOLTAGE (V)	4.70	3.35	4.70	3.35	4.70	3.35	4.70	3.35
TERMINAL No.	9	10	11	12	13	14	15	16
DC-VOLTAGE (V)	4.70	3.35	4.00	4.00	4.00	8.00	4.70	0

TA7796Z (V_{CC} = 8V, Ta = 25°C)

TERMINAL No.	1	2	3	4	5	6	7	8
DC-VOLTAGE (V)	4.70	3.35	4.00	4.00	4.00	8.00	4.70	0
TERMINAL No.	9	10	11	12	13	14	15	16
DC-VOLTAGE (V)	4.70	3.35	4.70	3.35	4.70	3.35	4.70	3.35

TEST CIRCUIT
TA7796P

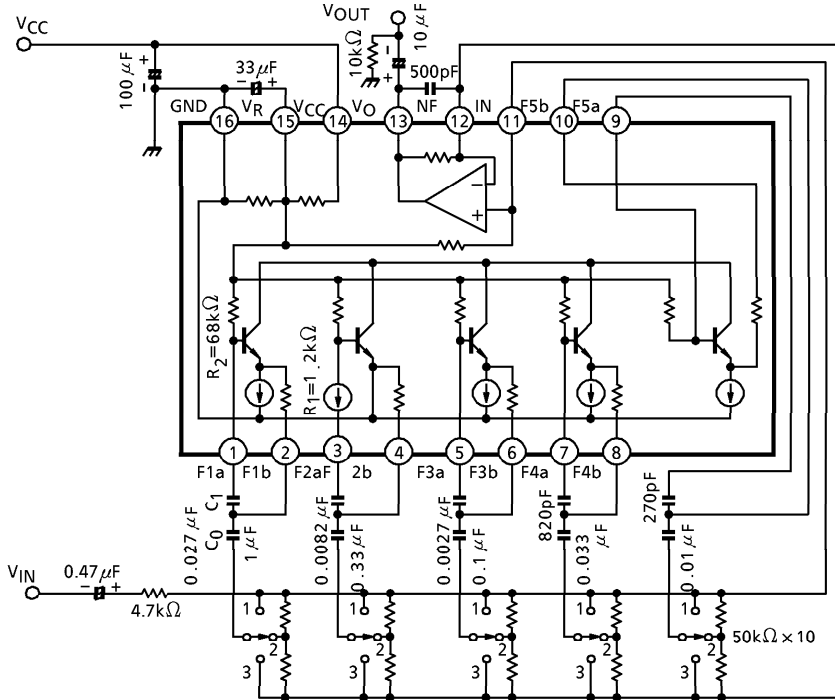

- 1 : CUT 2 : FLAT 3 : BOOST
- f_o (Resonance Frequency)

$$f_o = \frac{1}{2\pi \sqrt{C_0 \cdot C_1 \cdot R_1 \cdot R_2}}$$

($R_1 = 1.2k\Omega$, $R_2 = 68k\Omega$,
on chip resistor)

C_0 (F)	C_1 (F)	f_o (Hz)
1 μ	0.027 μ	107
0.33 μ	0.0082 μ	340
0.1 μ	0.0027 μ	1.07k
0.033 μ	820p	3.40k
0.01 μ	270p	10.7k

TA7796Z

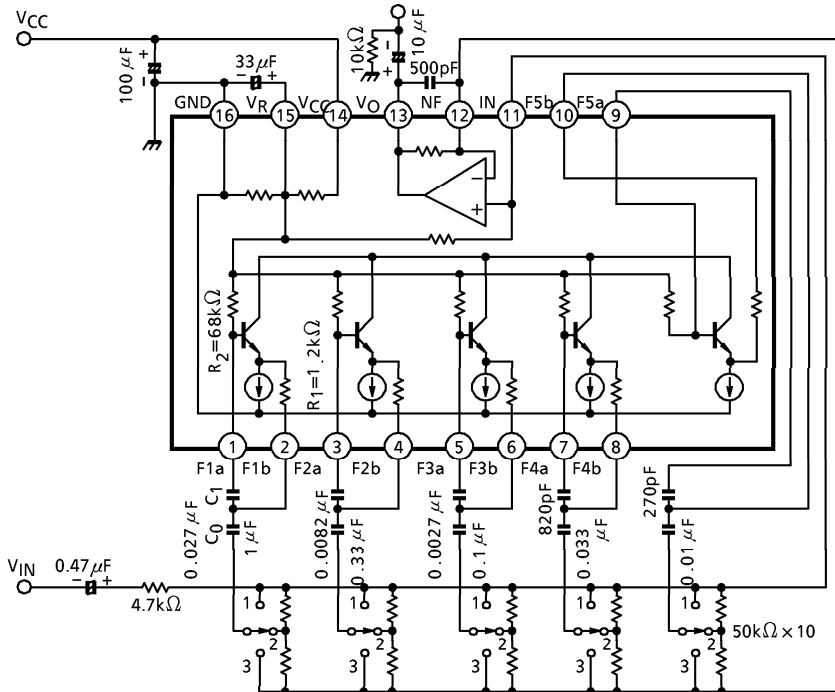

- 1 : CUT 2 : FLAT 3 : BOOST
- f_o (Resonance Frequency)

$$f_o = \frac{1}{2\pi \sqrt{C_0 \cdot C_1 \cdot R_1 \cdot R_2}}$$

($R_1 = 1.2k\Omega$, $R_2 = 68k\Omega$,
on chip resistor)

C_0 (F)	C_1 (F)	f_o (Hz)
1 μ	0.027 μ	107
0.33 μ	0.0082 μ	340
0.1 μ	0.0027 μ	1.07k
0.033 μ	820p	3.40k
0.01 μ	270p	10.7k

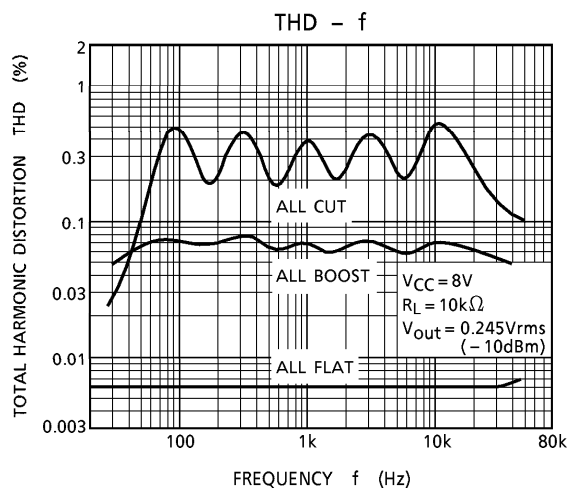
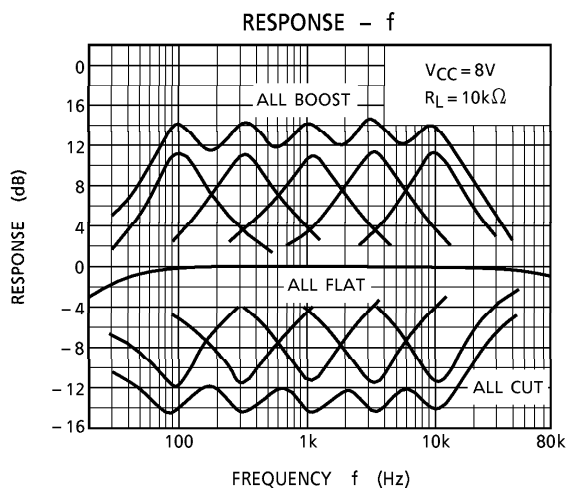
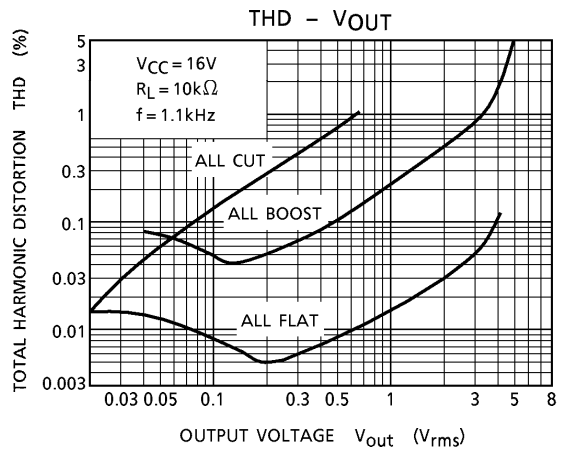
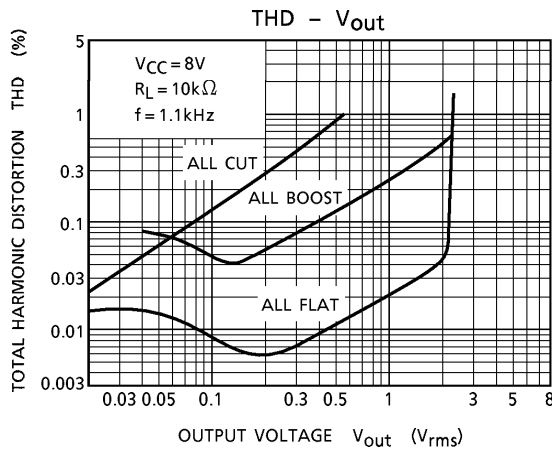
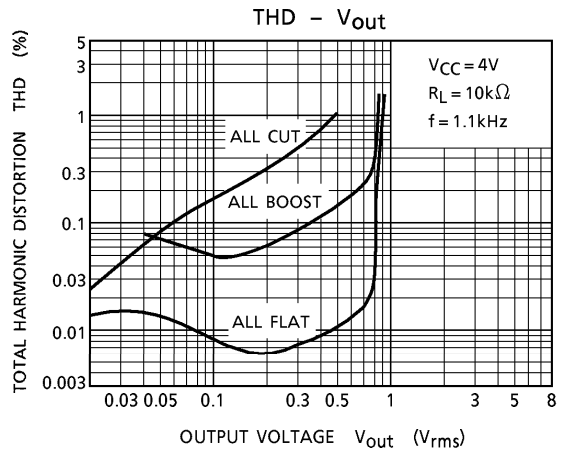
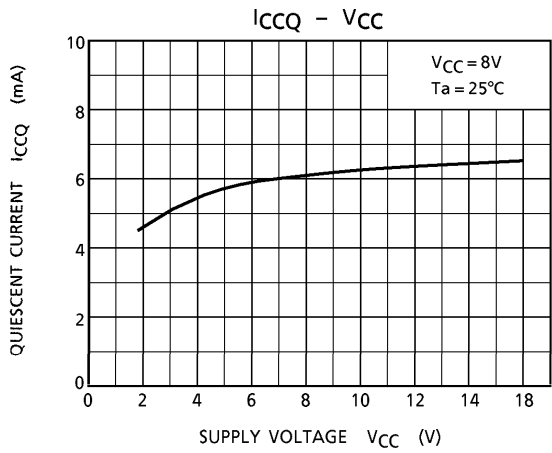

APPLICATION
TA7796P

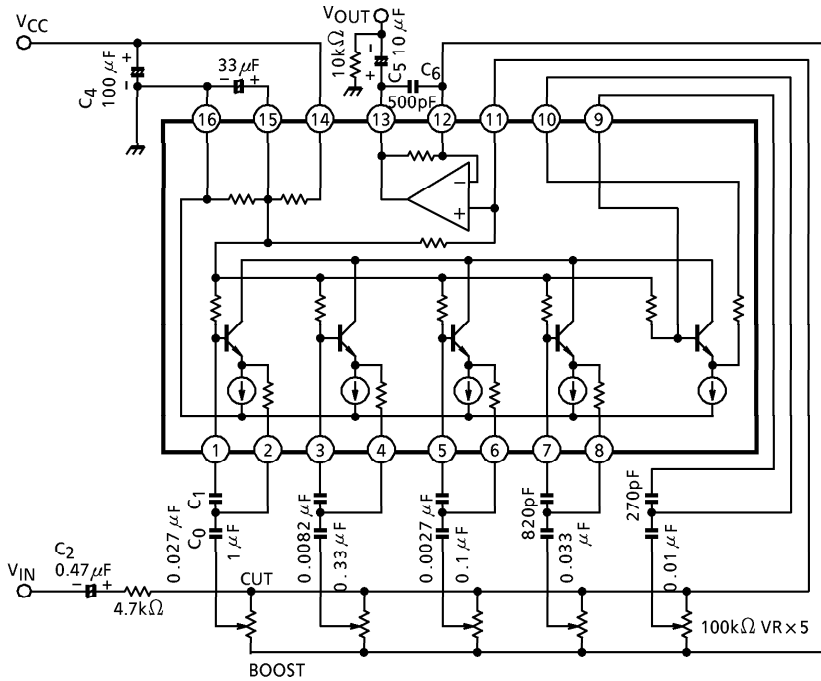

• Description of external parts.

C₀, C₁ : Capacitors used to fix f₀ (resonance frequency).

C₂ : Input capacitor.

C₃ : Decoupling capacitor.

C₄ : Power capacitor.

C₅ : Output capacitor.

TA7796Z

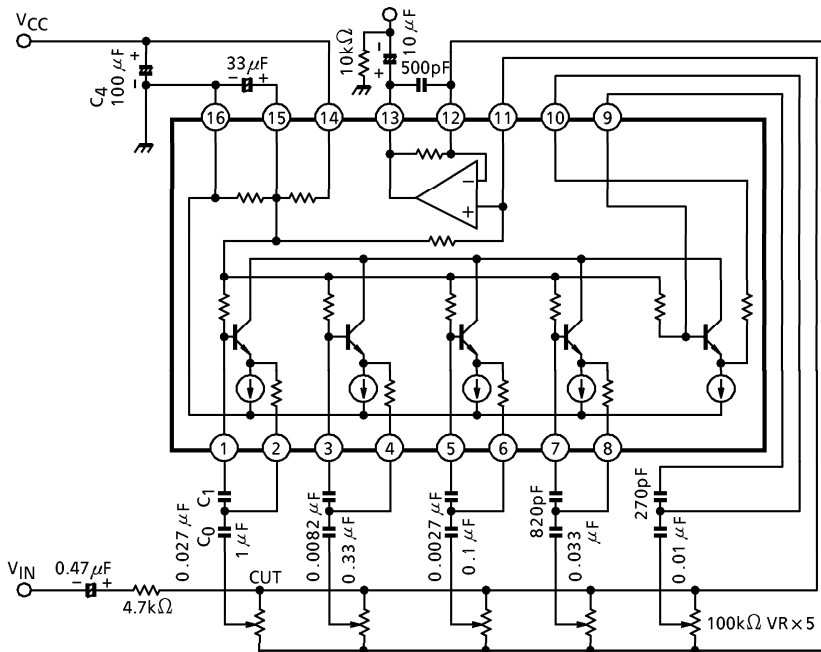

• Description of external parts.

C₀, C₁ : Capacitors used to fix f₀ (resonance frequency).

C₂ : Input capacitor.

C₃ : Decoupling capacitor.

C₄ : Power capacitor.

C₅ : Output capacitor.

PACKAGE DIMENSIONS
DIP16-P-300-2.54A

Unit : mm

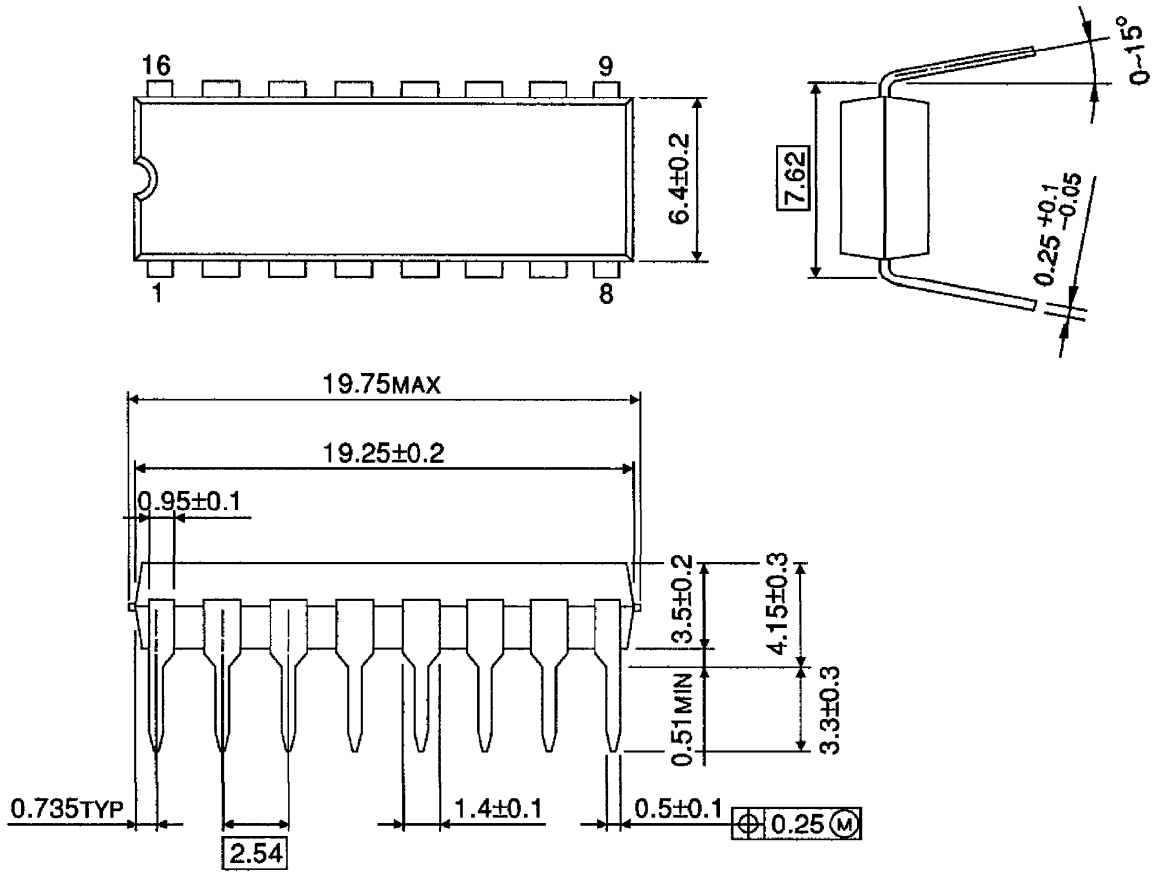

Weight : 1.0g (Typ.)

PACKAGE DIMENSIONS
ZIP16-P-1.27

Unit : mm

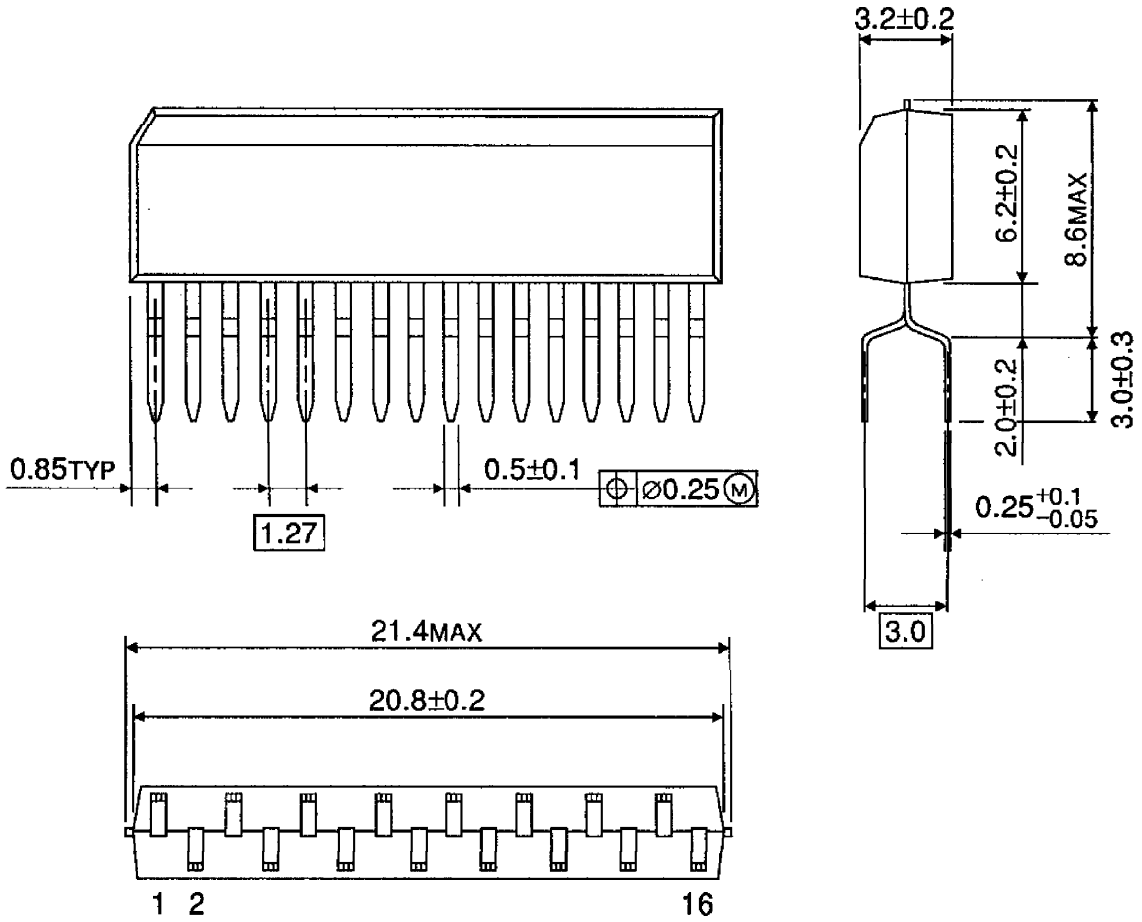

Weight : 0.99g (Typ.)

RESTRICTIONS ON PRODUCT USE

000707EBA

- TOSHIBA is continually working to improve the quality and reliability of its products. Nevertheless, semiconductor devices in general can malfunction or fail due to their inherent electrical sensitivity and vulnerability to physical stress. It is the responsibility of the buyer, when utilizing TOSHIBA products, to comply with the standards of safety in making a safe design for the entire system, and to avoid situations in which a malfunction or failure of such TOSHIBA products could cause loss of human life, bodily injury or damage to property. In developing your designs, please ensure that TOSHIBA products are used within specified operating ranges as set forth in the most recent TOSHIBA products specifications. Also, please keep in mind the precautions and conditions set forth in the "Handling Guide for Semiconductor Devices," or "TOSHIBA Semiconductor Reliability Handbook" etc..
- The TOSHIBA products listed in this document are intended for usage in general electronics applications (computer, personal equipment, office equipment, measuring equipment, industrial robotics, domestic appliances, etc.). These TOSHIBA products are neither intended nor warranted for usage in equipment that requires extraordinarily high quality and/or reliability or a malfunction or failure of which may cause loss of human life or bodily injury ("Unintended Usage"). Unintended Usage include atomic energy control instruments, airplane or spaceship instruments, transportation instruments, traffic signal instruments, combustion control instruments, medical instruments, all types of safety devices, etc.. Unintended Usage of TOSHIBA products listed in this document shall be made at the customer's own risk.
- The products described in this document are subject to the foreign exchange and foreign trade laws.
- The information contained herein is presented only as a guide for the applications of our products. No responsibility is assumed by TOSHIBA CORPORATION for any infringements of intellectual property or other rights of the third parties which may result from its use. No license is granted by implication or otherwise under any intellectual property or other rights of TOSHIBA CORPORATION or others.
- The information contained herein is subject to change without notice.