

AM / FM 1 CHIP TUNER SYSTEM IC (1.5V USE)

The TA7792P, TA7792F are AM / FM 1 chip tuner system (FM FRONT END + AM / FM IF) ICs, which are designed for low voltage operation (1.5V, 3.0V). Those are especially suitable for stereo headphone radio and radio cassette recorder equipments. These item can realize the low power dissipation and few external parts.

FEATURES

- AM detector coil-less
- FM mixer coil-less
- Switchover between AM / FM mode is possible with one-make switch.
- Operating supply voltage range
 $V_{CC}(\text{opr}) = 0.95 \sim 5V$ ($T_a = 25^\circ\text{C}$)
- Excellent low supply current ($V_{CC} = 1.5V$, $T_a = 25^\circ\text{C}$)
 $I_{CC}(\text{AM}) = 1.2\text{mA}$ (Typ.)
 $I_{CC}(\text{FM}) = 4.0\text{mA}$ (Typ.)

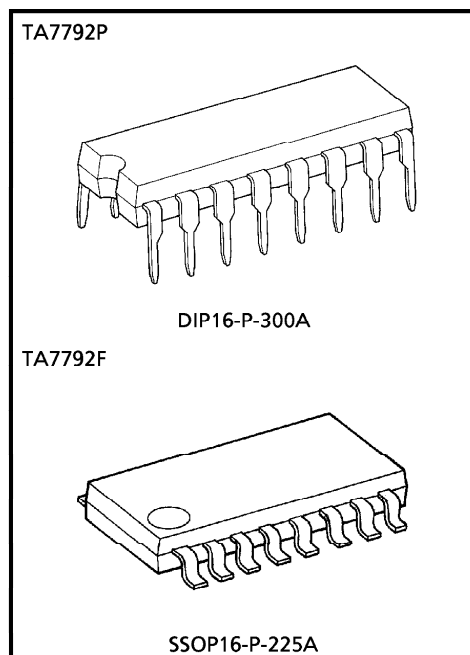

Weight DIP16-P-300A : 1.00g (Typ.)
SSOP16-P-225A : 0.14g (Typ.)

BLOCK DIAGRAM

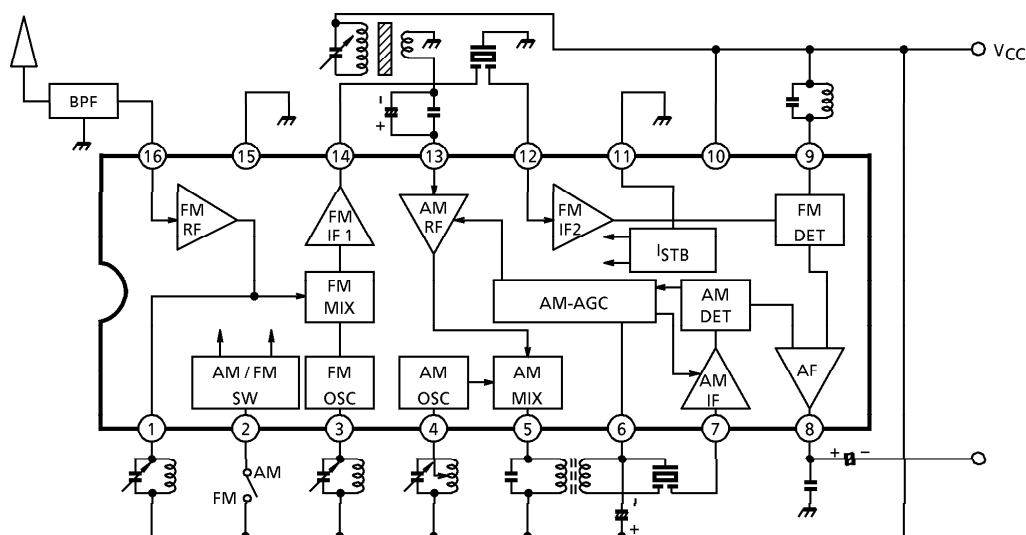

© The information contained herein is presented only as a guide for the applications of our products. No responsibility is assumed by TOSHIBA CORPORATION for any infringements of intellectual property or other rights of the third parties which may result from its use. No license is granted by implication or otherwise under any intellectual property or other rights of TOSHIBA CORPORATION or others.

© These TOSHIBA products are intended for use in general commercial applications (office equipment, communication equipment, measuring equipment, domestic appliances, etc.). please make sure that you consult with us before you use these TOSHIBA products in equipment which requires extraordinarily high quality and/or reliability, and in equipment which may involve life threatening or critical application, including but not limited to such uses as atomic energy control, airplane or spaceship instrumentation, traffic signals, medical instrumentation, combustion control, all types of safety devices, etc. TOSHIBA cannot accept and hereby disclaims liability for any damage which may occur in case the TOSHIBA products are used in such equipment or applications without prior consultation with TOSHIBA.

APPLICATION NOTE

<FM SECTION>

- RF amplifier (See Fig.1)

This stage is composed of the emitter-grounded and cascade connection amplifier.

The input impedance of pin⑩ is about 260Ω , which is determined by D_1 .

- Mixer amplifier (See Fig.2)

The amplified RF signal is transformed into IF signal by the mixer circuit which is composed of a differential amplifier.

The amplified IF signal is appeared through the emitter follower circuit at pin⑭. The output impedance of pin ⑭ is about 300Ω , due to match the impedance of the ceramic filter.

(Note)

The spurious characteristic is determined by the characteristic of the ceramic filter (10.7MHz), because the mixer coil is dispensable. It is possible to improve the spurious characteristic that the two ceramic filters of different characteristics are connected in series.

- IF limiter amplifier (See Fig.3)

The IF limiter amplifier is composed of six emitter-grounded amplifiers and a differential amplifier. The basis composition of the emitter-grounded amplifiers is shown as Fig.3.

- Detector circuit

This stage is composed of the quadrature detector circuit, which has double balanced.

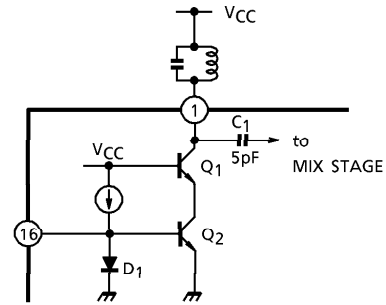

Fig.1

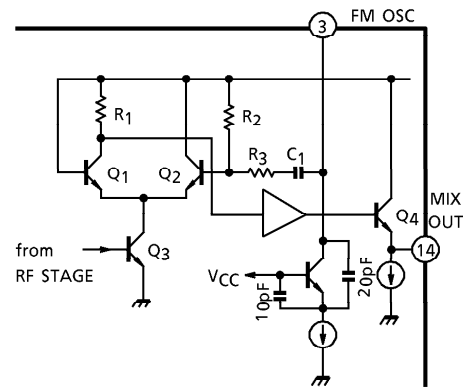

Fig.2

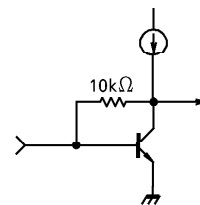

Fig.3

<AM SECTION>

● RF amplifier (See Fig.4)

This stage is composed of emitter-grounded amplifier, the input impedance of which has about $7.3k\Omega$. It is necessary to connect as Fig.4, because the condenser, C_1 is available to the audio by-pass of the RF-AGC, the noise of low frequency.

● Mixer circuit

The amplified RF signal is transformed into IF signal by the mixer circuit, which is composed of a differential amplifier.

● IF amplifier

This stage is composed of four emitter-grounded amplifiers and the two differential amplifiers. The input impedance is rather high, because it is changed by the amplitude of input signal (AGC level). So the input terminal of the IF amplifier must be matched with the impedance of ceramic filter.

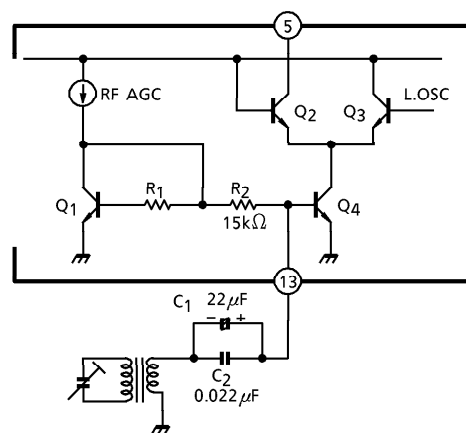

Fig.4

<COMMON SECTION>

● AM / FM mode switchover

Switchover between AM / FM mode is possible with one-make switch. In case of the opened, this IC has AM mode.

Another in case that the terminal is connected to V_{CC} directly, that has FM mode.

And the terminal of pin② is V_{CC} terminal of FM FRONT END section, too.

● Output circuit (See Fig.5)

Both of the AM / FM detector signal is appeared through the pin⑧.

Those output are chosen by the mode switchover. At the same time, the output impedance is changed as follow at AM / FM mode, due to cut the AM carrier signal and pass the FM composite signal smoothly, with only one condenser.

$$R_{out}(AM) = 8k\Omega \text{ (Typ.)}$$

$$R_{out}(FM) = 1.4k\Omega \text{ (Typ.)}$$

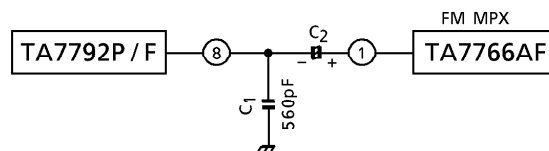

Fig.5

MAXIMUM RATINGS (Ta = 25°C)

CHARACTERISTIC	SYMBOL	RATING	UNIT
Supply Voltage	V _{CC}	5	V
Power Dissipation	TA7792P	750	mW
	TA7792F	350	
Operating Temperature	T _{opr}	-25~75	°C
Storage Temperature	T _{stg}	-55~150	°C

(Note) Derated above Ta = 25°C in the proportion of 6mW/°C for TA7792P, and of 2.8mW/°C for TA7792F.

ELECTRICAL CHARACTERISTICS

Unless otherwise specified, Ta = 25°C, V_{CC} = 1.5V

FM : V_{in} = 60dB μ V EMF, f = 83MHz, f_m = 1kHz, Δ f = \pm 22.5kHz

AM : V_{in} = 60dB μ V EMF, f = 1MHz, f_m = 1kHz, MOD = 30%

CHARACTERISTIC	SYMBOL	TEST CIR-CUIT	TEST CONDITION	MIN.	TYP.	MAX.	UNIT	
Supply Current	I _{CC} (FM)	1	V _{in} = 0	—	4.0	5.2	mA	
	I _{CC} (AM)	1	V _{in} = 0	—	1.2	1.8		
FM	Input Limiting Voltage	V _{in} (lim)	-3dB limiting	—	10	16	dB μ V EMF	
	Total Harmonic Distortion	THD (FM)		—	0.25	—	%	
	Signal To Noise Ratio	S/N (FM)		—	62	—	dB	
	Quiescent Sensitivity	Q _S		S/N = 30dB	—	12	—	dB μ V EMF
	AM Rejection Ratio	AMR		MOD = 30%	—	30	—	dB
	Oscillator Voltage	V _{osc}	2	f = 60MHz	53	90	135	mV _{rms}
	Oscillator Stop Supply Voltage	V _{stop} (FM)	1	V _{in} < -20dB μ V EMF	—	0.85	0.95	V
	Recovered Output Voltage	V _{OD} (FM)	1		28	45	68	mV _{rms}
AM	Voltage Gain	G _V	V _{in} = 30dB μ V EMF	14	25	50	mV _{rms}	
	Recovered Output Voltage	V _{OD} (AM)		25	40	60	mV _{rms}	
	Total Harmonic Distortion	THD (AM)		—	1.5	—	%	
	Signal To Noise Ratio	S/N (AM)		—	40	—	dB	
	Oscillator Stop Supply Voltage	V _{stop} (AM)	1	V _{in} < -20dB μ V EMF	—	0.85	0.95	V
Output Resistance Pin [Ⓢ]	FM	R _O (FM)	f = 1kHz	—	1.4	—	k Ω	
	AM	R _O (AM)	f = 1kHz	—	8	—		

※ V_{in} : Open Display

TERMINAL VOLTAGE : Terminal voltage at no signal with test circuit ($V_{CC} = 1.5V$, $T_a = 25^\circ C$)

PIN No. PIN NAME	SYMBOL	TYP.		UNIT	PIN No. PIN NAME	SYMBOL	TYP.		UNIT		
		AM	FM				AM	FM			
1	FM RF OUT	V ₁	—	1.5	V	9	FM DET	V ₉	1.5	1.5	V
2	V _{CC1}	V ₂	—	1.5	V	10	V _{CC2}	V ₁₀	1.5	1.5	V
3	FM OSC	V ₃	—	1.5	V	11	GND2	V ₁₁	0	0	V
4	AM OSC	V ₄	1.5	1.5	V	12	FM IF IN	V ₁₂	—	0.7	V
5	AM MIX OUT	V ₅	1.5	1.5	V	13	AM RF IN	V ₁₃	0.7	—	V
6	AM AGC	V ₆	0.8	—	V	14	FM MIX OUT	V ₁₄	—	0.8	V
7	AM IF IN	V ₇	1.4	1.5	V	15	GND1	V ₁₅	0	0	V
8	AF OUT	V ₈	0.6	0.6	V	16	FM RF IN	V ₁₆	—	0.7	V

TEST CIRCUIT 1

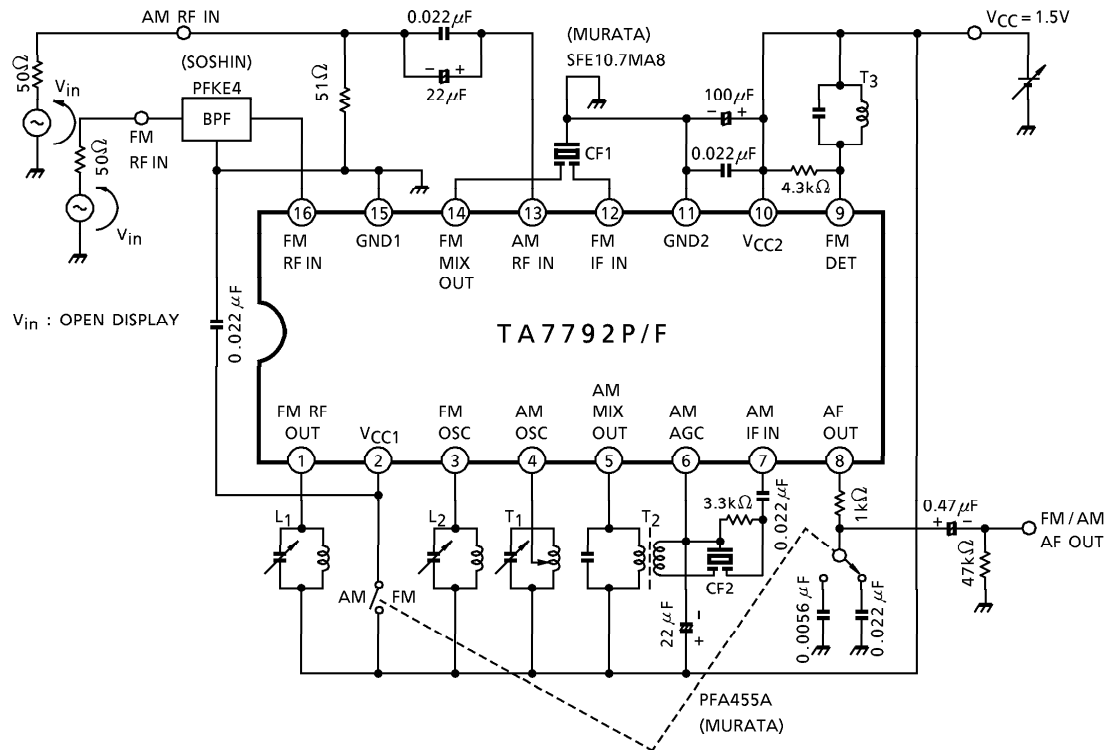

TEST CIRCUIT 2

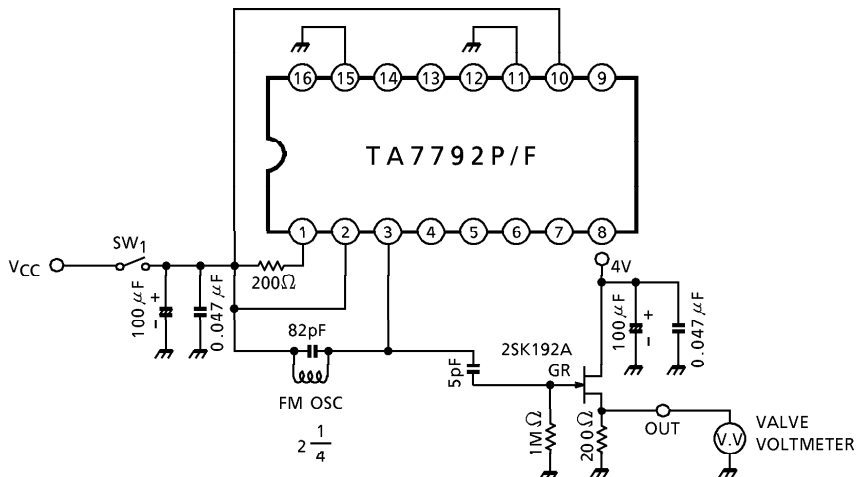

COIL DATA (Test circuit)

Ⓢ : SUMIDA ELECTRIC Co., Ltd.

COIL STAGE	TEST FREQUENCY	L (μH)	C ₀ (pF)	Q ₀	TURN				WIRE (mm φ)	REFERENCE
					1-2	2-3	1-3	4-6		
L ₁ FM RF	100MHz	0.053	—	100	—	—	1 $\frac{3}{4}$	—	0.5UEW	Ⓢ 0258-000-020
L ₂ FM OSC	100MHz	0.065	—	100	—	—	2 $\frac{1}{4}$	—	0.5UEW	Ⓢ 0258-000-021
T ₁ AM OSC	796kHz	288	—	115	13	73	—	—	0.08UEW	Ⓢ 4147-1356-038
T ₂ AM IFT	455kHz	—	180	120	—	—	180	15	0.06UEW	Ⓢ 2150-2162-165
T ₃ FM DET	10.7MHz	—	82	110	—	—	13	—	0.12UEW	Ⓢ 4152-4095-015

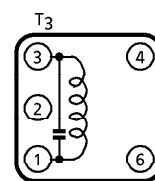
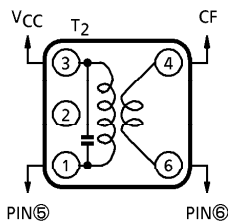
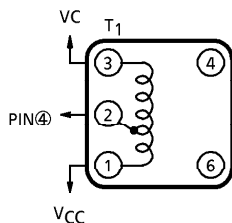
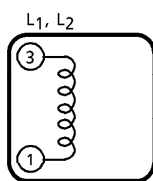

CHARACTERISTICS CURVES

FM (F/E + IF) V_{OD} , AMR, V_{no} , THD - V_{in}

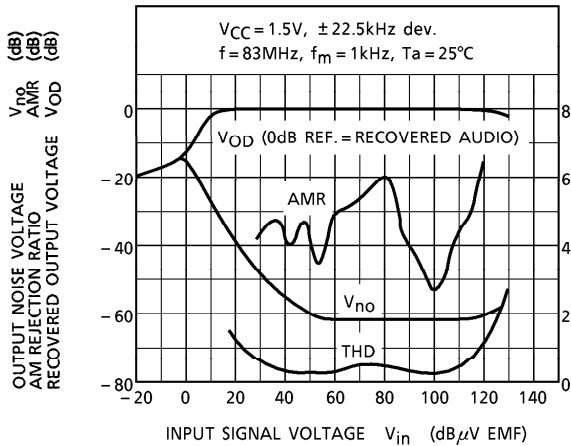

FM (IF) V_{OD} , AMR, V_{no} , THD - V_{in}

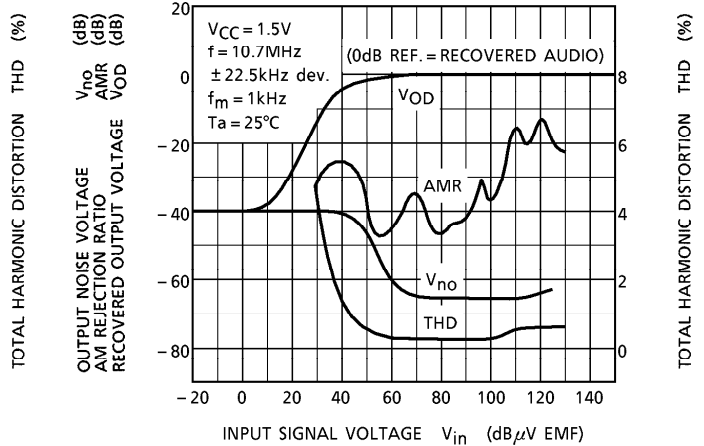

AM I_{CC} , V_{OD} - V_{CC}

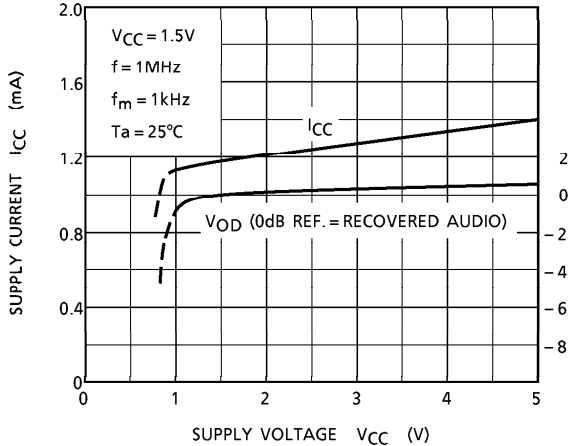

FM (F/E + IF) Q_s , $V_{in}(lim)$, Δf_{osc} , I_{CC} - V_{CC}

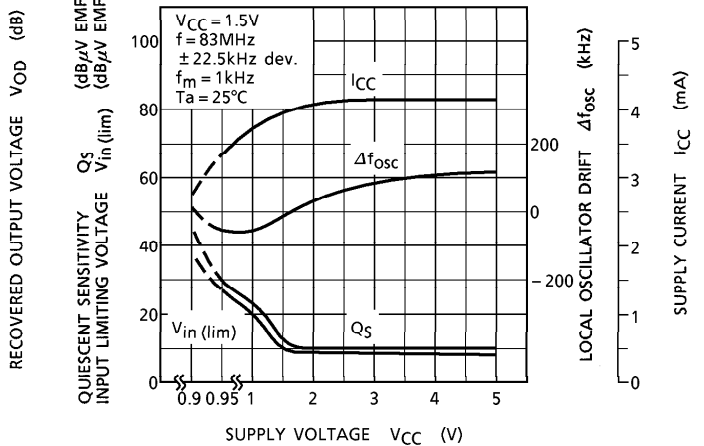

FM (IF) V_{OD} , V_8 (DC), THD - Δf

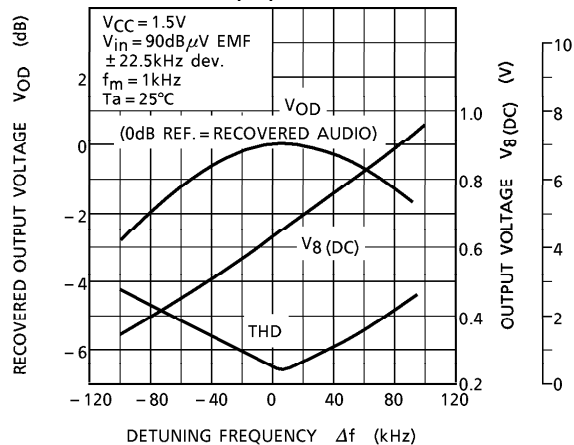

AM V_{OD} , V_{no} , THD - V_{in}

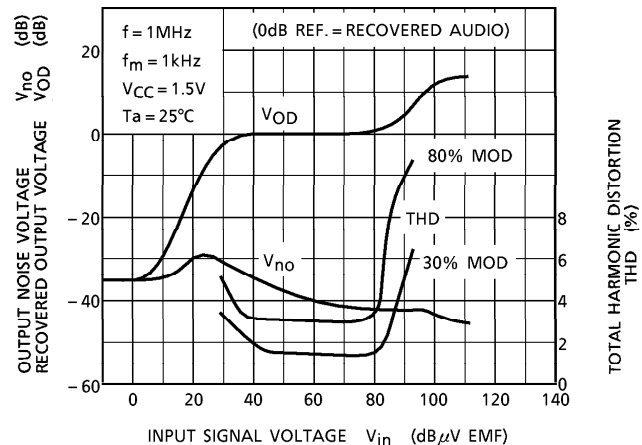

OUTLINE DRAWING
DIP16-P-300A

Unit : mm

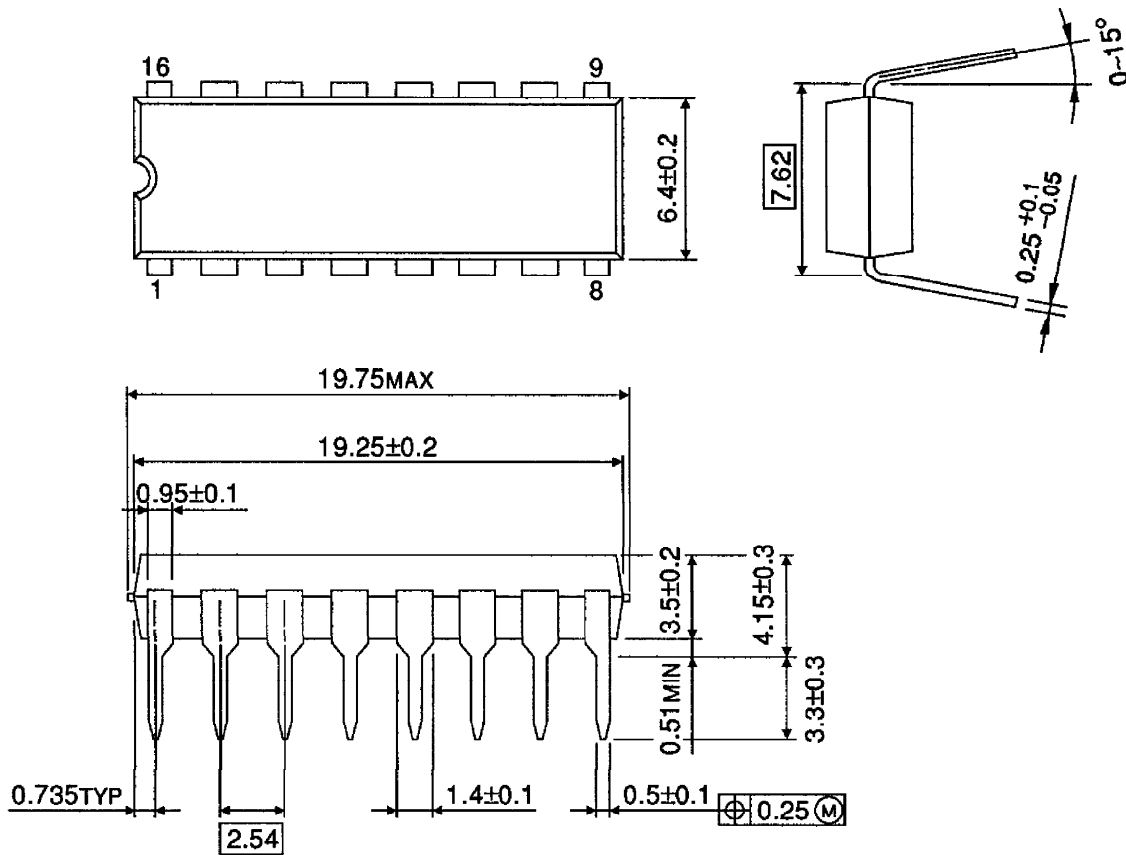

Weight : 1.00g (Typ.)

TA7792P - 8
1996 - 4 - 22
TOSHIBA CORPORATION

OUTLINE DRAWING
SSOP16-P-225A

Unit : mm

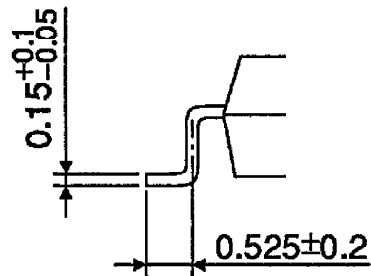
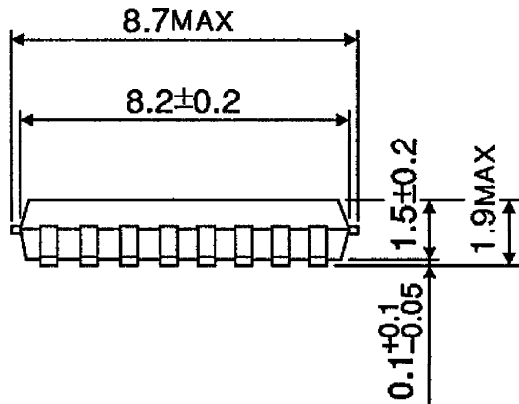
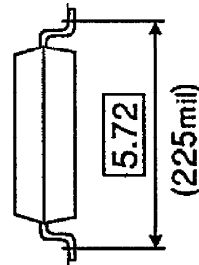
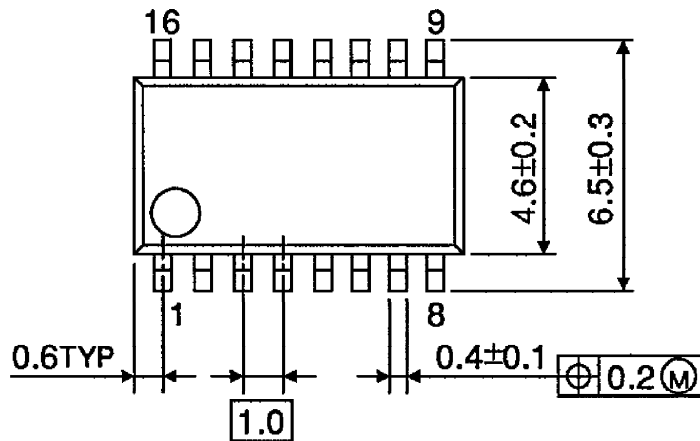

Weight : 0.14g (Typ.)