

TOSHIBA BIPOLAR LINEAR INTEGRATED CIRCUIT SILICON MONOLITHIC

TA7279P, TA7279AP

DUAL BRIDGE DRIVER

The TA7279P, TA7279AP are dual bridge driver designed for DC motor rotation control.

FEATURES

- Wide Range of Operating Voltage
: $V_{CC (opr.)} = 6\sim 18\text{ V (P, AP)}$,
 $V_S (opr.) = 0\sim 16\text{ V (P)} / 0\sim 18\text{ V (AP)}$
- Output Current Up to 1.0 A (AVE.), 3.0 A (PEAK)
- Built-in Thermal Shut Down and Current Limiter
- Input Hysteresis for Stable Operation

BLOCK DIAGRAM

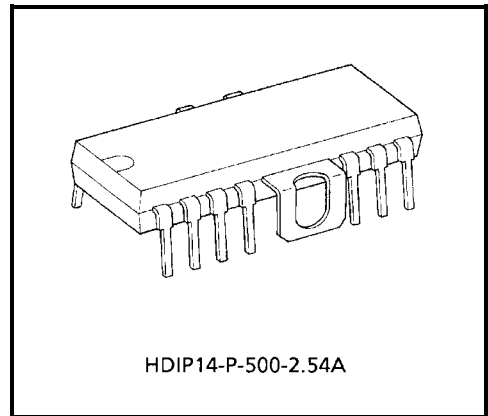

Weight: 3.00 g (Typ.)

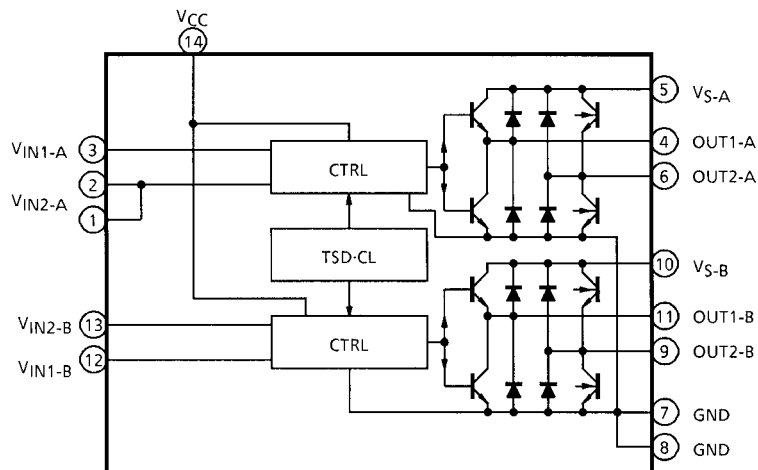

PIN FUNCTION

PIN No.	SYMBOL	FUNCTIONAL DESCRIPTION
1	V _{IN2-A}	A-ch input terminal
2	V _{IN2-A}	
3	V _{IN1-A}	A-ch input terminal
4	OUT1-A	A-ch output terminal
5	V _{S-A}	A-ch Motor drive power supply
6	OUT2-A	A-ch output terminal
7	GND	GND terminal
8	GND	
9	OUT2-B	B-ch output terminal
10	V _{S-B}	B-ch Motor drive power supply
11	OUT1-B	B-ch output terminal
12	V _{IN1-B}	B-ch input terminal
13	V _{IN2-B}	B-ch input terminal
14	V _{CC}	Logic power supply

APPLICATION NOTE

(1) Input circuit

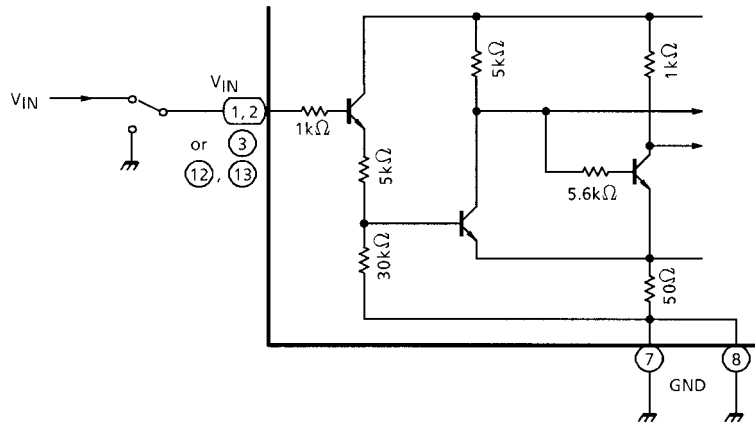

Input terminals of (2), (3), (12) and (13) Pin are all high active type and have a hysteresis. 3 μ A Typ. of input current is required.

The input circuit is an active high type, as shown in the diagram. When voltage higher than the specified $V_{IN(H)}$ is applied, the output is logic "H". When voltage lower than the specified $V_{IN(L)}$ is applied or if the input is grounded, the output is logic "L". Since the input current I_N flows to the input when logic "H", be careful with the output impedance at the previous step.

(2) Output circuit

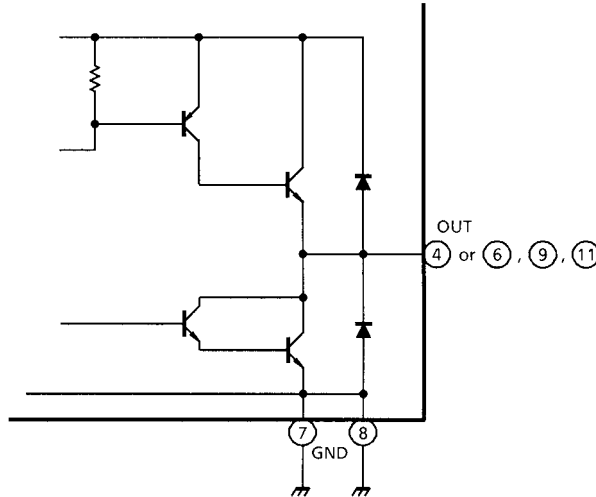

FUNCTION

IN1	IN2	OUT1	OUT2	MODE
1	1	L	L	Brake
0	1	L	H	CW / CCW
1	0	H	L	CCW / CW
0	0	High Impedance		STOP

MAXIMUM RATINGS (Ta = 25°C)

CHARACTERISTIC		SYMBOL	RATING	UNIT
Supply Voltage	AP	V _{CC} (MAX.)	25	V
	P		20	
Motor Drive Voltage	AP	V _S (MAX.)	25	V
	P		18	
Output Current	PEAK	I _O (PEAK)	3.0	A
	AVE.	I _O (AVE.)	1.0	
Power Dissipation		P _D (Note)	2.3	W
Operating Temperature		T _{opr}	-30~75	°C
Storage Temperature		T _{stg}	-55~150	°C

Note: No heat sink.

ELECTRICAL CHARACTERISTICS (Ta = 25°C)

CHARACTERISTIC		SYMBOL	TEST CIR-CUIT	TEST CONDITION	MIN	TYP.	MAX	UNIT
Supply Current		I _{CC1}	1	V _{CC} = 18 V, Output Off, Stop mode	14	28	41	mA
		I _{CC2}	1	V _{CC} = 18 V, Output Off, CW / CCW mode	10	29	38	
		I _{CC3}	1	V _{CC} = 18 V, Output Off, Brake mode	8	20	35	
Input Operating Voltage	1 (High)	V _{IN} (H)	—	T _J = 25°C	3.0	—	V _{CC}	V
	2 (Low)	V _{IN} (L)	—	T _J = 25°C	—	—	0.8	
Input Current		I _{IN}	2	Sink, V _{IN} = 3 V	—	3	10	μA
Output Saturation Voltage	Upper	V _{SATU-1}	3	I _O = 0.1 A, V _{CC} = V _S = 18 V	—	—	1.1	V
	Lower	V _{SATL-1}	3	I _O = 0.1 A, V _{CC} = V _S = 18 V	—	—	1.0	
	Upper	V _{SATU-2}	3	I _O = 1.0 A, V _{CC} = V _S = 18 V	—	1.2	1.5	
	Lower	V _{SATL-2}	3	I _O = 1.0 A, V _{CC} = V _S = 18 V	—	1.05	1.4	
Leakage Current	Upper	I _{LU}	—	V _S = 25 V	—	—	50	μA
	Lower	I _{LL}	—	V _S = 25 V	—	—	50	
Diode Forward Drop	Upper	V _{FU}	4	I _F = 1 A	—	2.0	—	V
	Lower	V _{FL}	4	I _F = 1 A	—	1.3	—	

TEST CIRCUIT 1.

$I_{CC1, 2, 3}$

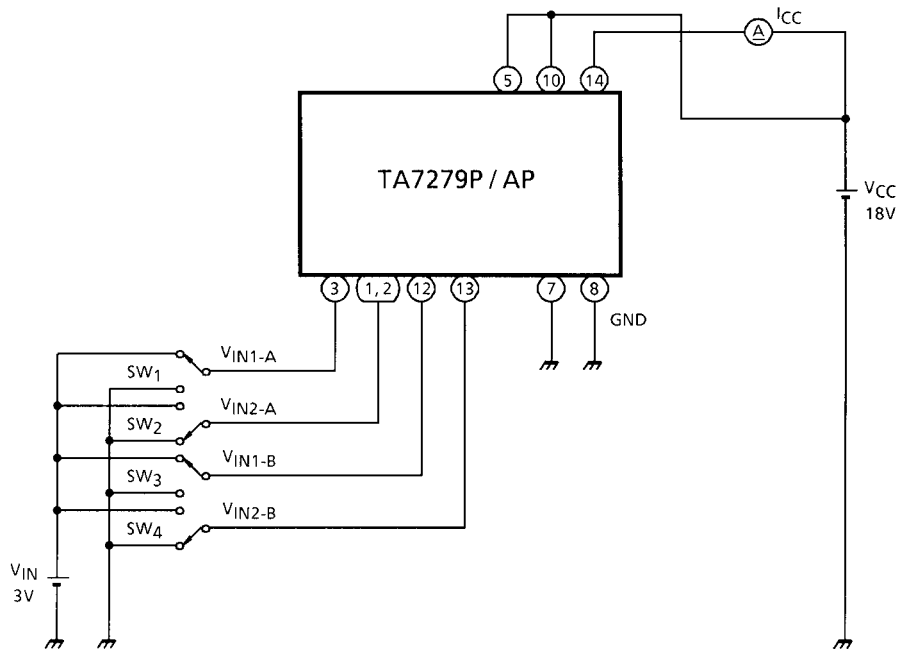

TEST CIRCUIT 2.

I_{IN} (H), (L)

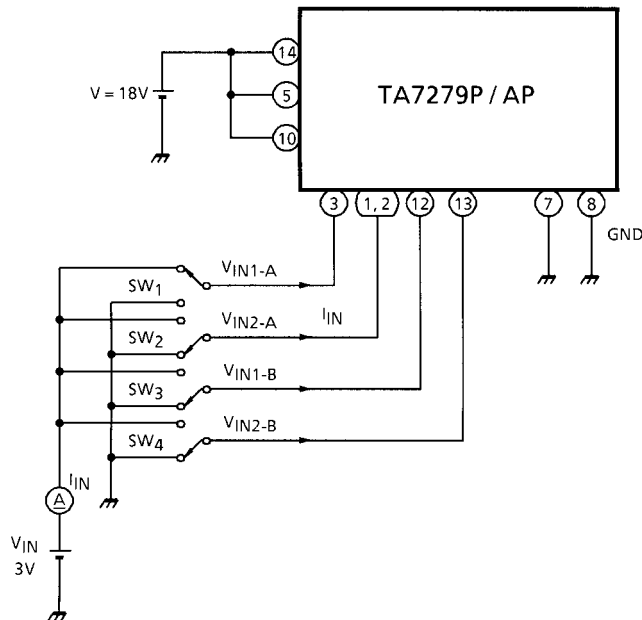

TEST CIRCUIT 3.
 $V_{SATU-1, 2} / V_{SATL-1, 2}$

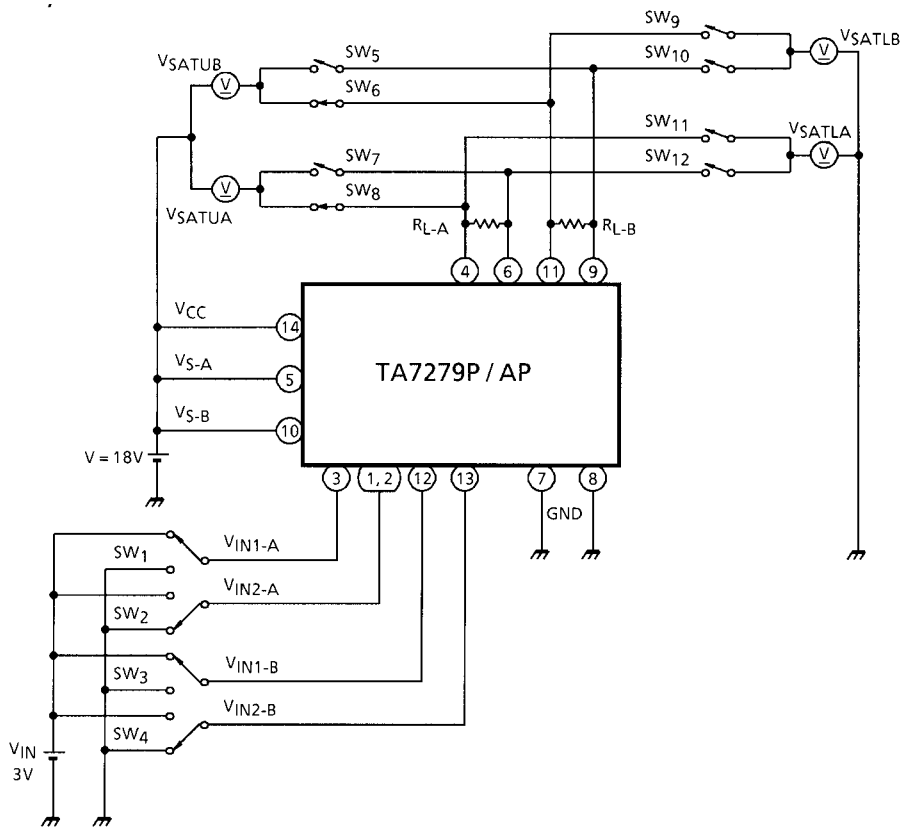

TEST CIRCUIT 4.
 $V_{FU, L}$

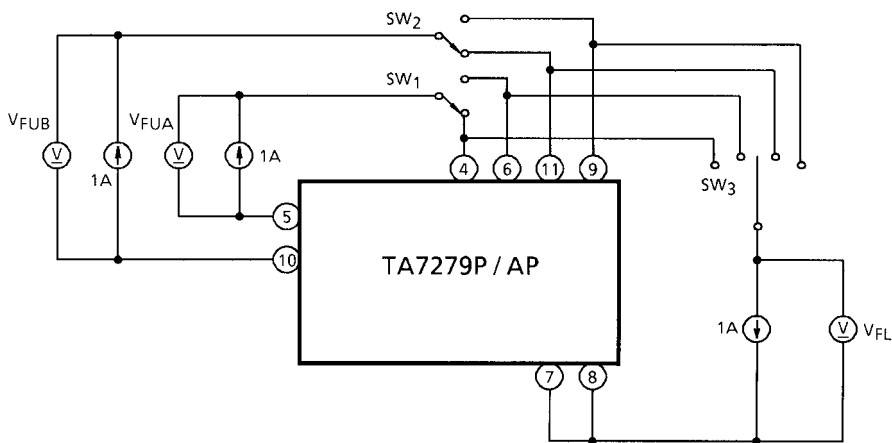

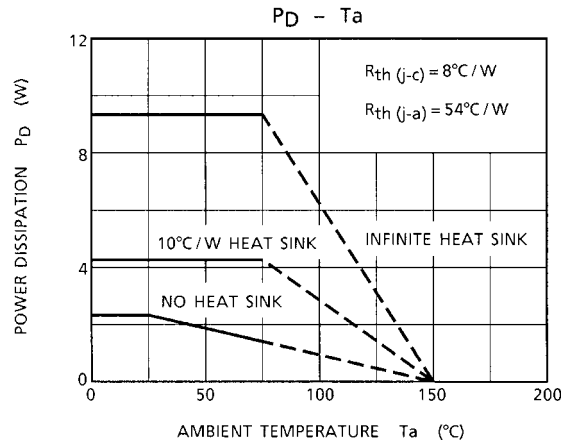

APPLICATION CIRCUIT

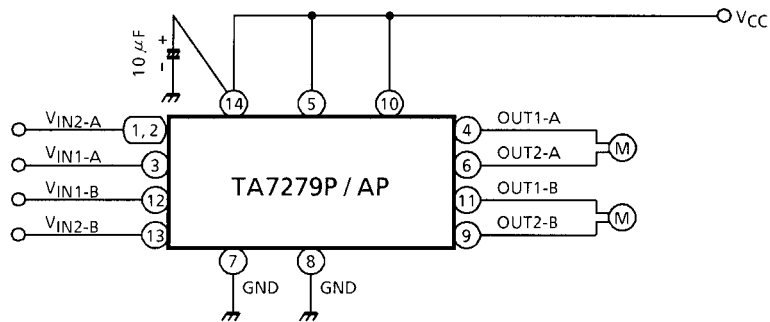

Problems may result if a capacitor is inserted in parallel to the motor as a measure against noise. If measures against noise are necessary, connect capacitors as shown in the diagram below. A larger bypass capacitor between VCC and GND is effective against noise and other problems. (A capacitance higher than 100 µF is recommended.)

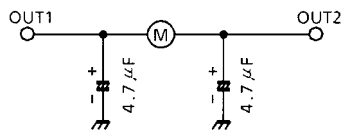

Note: Utmost care is necessary in the design of the output line, VS and GND line since IC may be destroyed due to short-circuit between outputs, air contamination fault, or fault by improper grounding.

PACKAGE DIMENSIONS

HDIP14-P-500-2.54A

Unit: mm

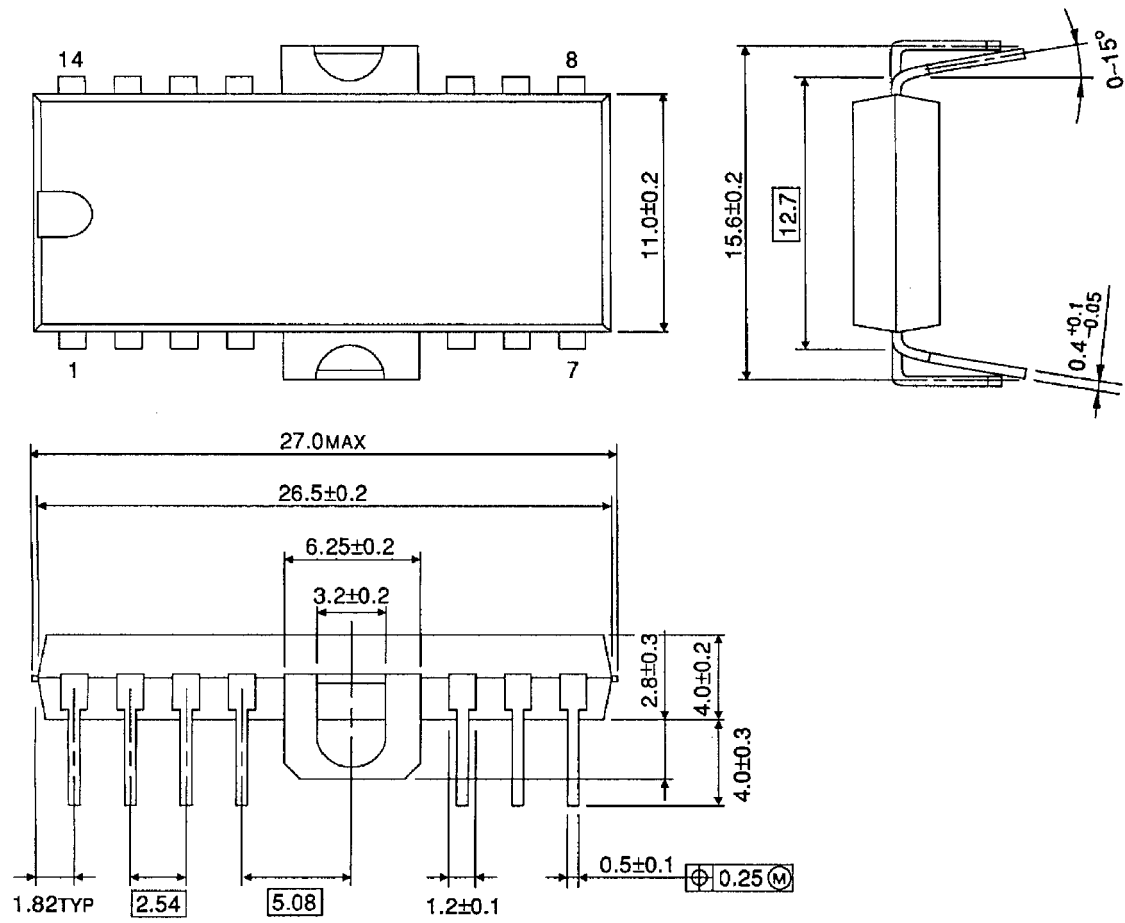

Weight: 3.00 g (Typ.)

RESTRICTIONS ON PRODUCT USE

000707EBA

- TOSHIBA is continually working to improve the quality and reliability of its products. Nevertheless, semiconductor devices in general can malfunction or fail due to their inherent electrical sensitivity and vulnerability to physical stress. It is the responsibility of the buyer, when utilizing TOSHIBA products, to comply with the standards of safety in making a safe design for the entire system, and to avoid situations in which a malfunction or failure of such TOSHIBA products could cause loss of human life, bodily injury or damage to property.
In developing your designs, please ensure that TOSHIBA products are used within specified operating ranges as set forth in the most recent TOSHIBA products specifications. Also, please keep in mind the precautions and conditions set forth in the "Handling Guide for Semiconductor Devices," or "TOSHIBA Semiconductor Reliability Handbook" etc..
- The TOSHIBA products listed in this document are intended for usage in general electronics applications (computer, personal equipment, office equipment, measuring equipment, industrial robotics, domestic appliances, etc.). These TOSHIBA products are neither intended nor warranted for usage in equipment that requires extraordinarily high quality and/or reliability or a malfunction or failure of which may cause loss of human life or bodily injury ("Unintended Usage"). Unintended Usage include atomic energy control instruments, airplane or spaceship instruments, transportation instruments, traffic signal instruments, combustion control instruments, medical instruments, all types of safety devices, etc.. Unintended Usage of TOSHIBA products listed in this document shall be made at the customer's own risk.
- The products described in this document are subject to the foreign exchange and foreign trade laws.
- The information contained herein is presented only as a guide for the applications of our products. No responsibility is assumed by TOSHIBA CORPORATION for any infringements of intellectual property or other rights of the third parties which may result from its use. No license is granted by implication or otherwise under any intellectual property or other rights of TOSHIBA CORPORATION or others.
- The information contained herein is subject to change without notice.