

**TA7270P
TA7271P**

T-74-05-01

5.8W DUAL AUDIO POWER AMPLIFIER.
19W BTL AUDIO POWER AMPLIFIER.

The TA7270P/TA7271P are dual audio power amplifier for consumer applications. It is designed for high power, low distortion and low noise. It also contains various kind of protectors. It is suitable for car-audio power amplifier with high performance.

- Two Kinds of Pin Configuration are Available: Normal (TA7270P) and Reverse (TA7271P) for Easier Layout Design of PC-board when Used in BTL-Stereo Application.

- Operating Supply Voltage Range:
VCC (opr)=9 ~ 18V

- High Power
VCC=13.2V, f=1kHz, RL=4Ω

BTL	19W (Typ.)	THD=10%
	15W (Typ.)	THD=1%
DUAL	5.8W (Typ.)	THD=10%

- Low Distortion
VCC=13.2V, f=1kHz, RL=4Ω

BTL	0.03% (Typ.)	POUT=4W, Gv=40dB
DUAL	0.06% (Typ.)	POUT=1W, Gv=52dB

- Low Noise
VCC=13.2V, RL=4Ω

BTL	0.14mVrms (Typ.)	Gv=40dB, Rg=0, DIN NOISE: DIN 45405
DUAL	0.7 mVrms (Typ.)	Gv=52dB, Rg=10kΩ, BW=20Hz ~ 20kHz

- Protector: Thermal Shut Down, Over Voltage Protection.
BTL-OCL DC Short Protection.

Unit in mm

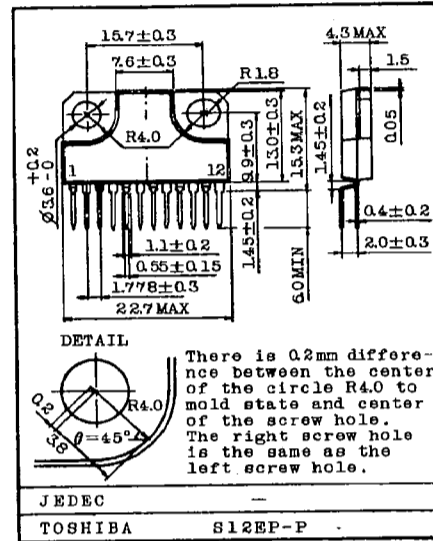

Weight : 4.04g (TYP.)

AUDIO LINEAR IC

9097247 TOSHIBA, ELECTRONIC

02E 16987 D

TA7270P
TA7271P

T-74-05-01

MAXIMUM RATINGS (Ta=25°C)

CHARACTERISTIC	SYMBOL	RATING	UNIT
Peak Supply Voltage (0.2 sec)	V _{CC surge}	45	V
DC Supply Voltage	V _{CC DC}	25	V
Operating Supply Voltage	V _{CC opr}	18	V
Output Current (peak)	I _{O(peak)}	4.5	A
Power Dissipation	P _D	25	W
Operating Temperature	T _{opr}	-30 ~ 75	°C
Storage Temperature	T _{stg}	-55 ~ 150	°C

ELECTRICAL CHARACTERISTICS

(Unless otherwise specified, V_{CC}=13.2V, R_L=4Ω, R_g=600Ω, f=1kHz, Ta=25°C)

CHARACTERISTIC	SYMBOL	TEST CIR-CUIT	TEST CONDITION	MIN.	TYP.	MAX.	UNIT	
Quiescent Current	I _{CCQ}	2	V _{IN} =0	-	80	145	mA	
BTL CONNECTION MODE	Output Power	P _{OUT(1)}	THD=10%	16	19	-	W	
		P _{OUT(2)}	THD=1%	12	15	-	W	
	Total Harmonic Distortion	THD(1)	P _{OUT} =4W, G _v =40dB	-	0.03	0.25	%	
	Output Offset Voltage	V _{OFF}	1	V _{IN} =0	-	0	0.35	V
	Voltage Gain	G _{v(1)}	1	V _{OUT} =0dBm	-	40	-	dB
	Output Noise Voltage	V _{NO(1)}	1	R _g =0 DIN45405 Noise Filter	-	0.14	-	mV _{rms}
	Ripple Rejection Ratio	R.R(1)	1	f _{ripple} =100Hz V _{ripple} =0dBm	-	-52	-40	dB
DUAL MODE	Output Power	P _{OUT(3)}	2	THD=10%	5	5.8	-	W
	Total Harmonic Distortion	THD(2)	2	P _{OUT} =1W	-	0.06	0.30	%
	Voltage Gain	G _{v(2)}	2	V _{OUT} =0dBm	50	52	54	dB
	Voltage Gain Ratio	4G _v	2	V _{OUT} =0dBm	-1	0	1	dB
	Output Noise Voltage	V _{NO(2)}	2	R _g =10kΩ BW=20Hz ~ 20kHz	-	0.7	1.5	mV _{rms}
	Ripple Rejection Ratio	R.R(2)	2	f _{ripple} =100Hz V _{ripple} =0dBm	-	-52	-40	dB
	Cross Talk	C.T	2	V _{OUT} =0dBm	-	-57	-	dB
Input Resistance	R _{IN}	2	f=1kHz	-	33	-	kΩ	

TOSHIBA

TA7270P
TA7271P
T-74-05-01

TEST CIRCUIT/APPLICATION CIRCUIT

TA7270P

(1) BTL AMPLIFIER

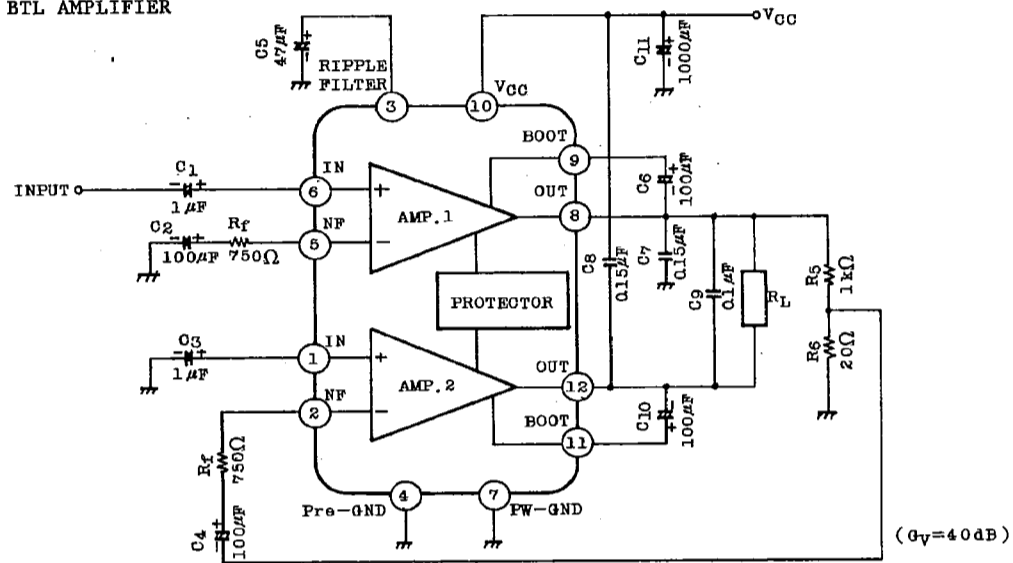

(2) DUAL AMPLIFIER

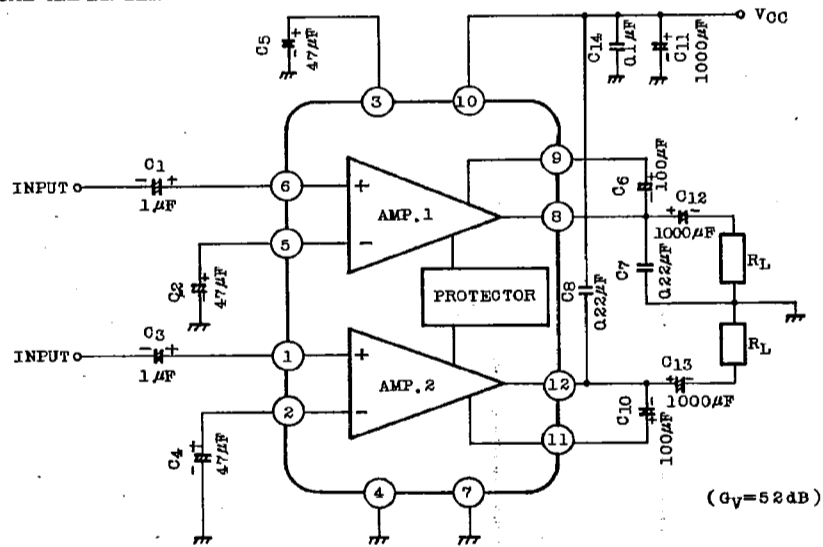

AUDIO LINEAR IC

TA7270P
TA7271P

T-74-05-01

TEST CIRCUIT/APPLICATION CIRCUIT

TA7271P

(1) BTL AMPLIFIER

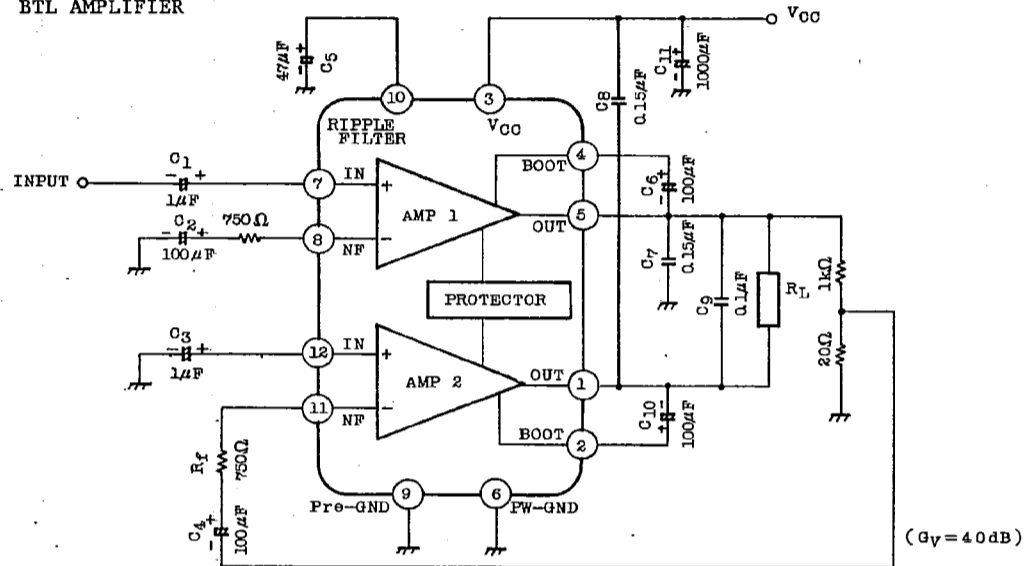

(2) DUAL AMPLIFIER

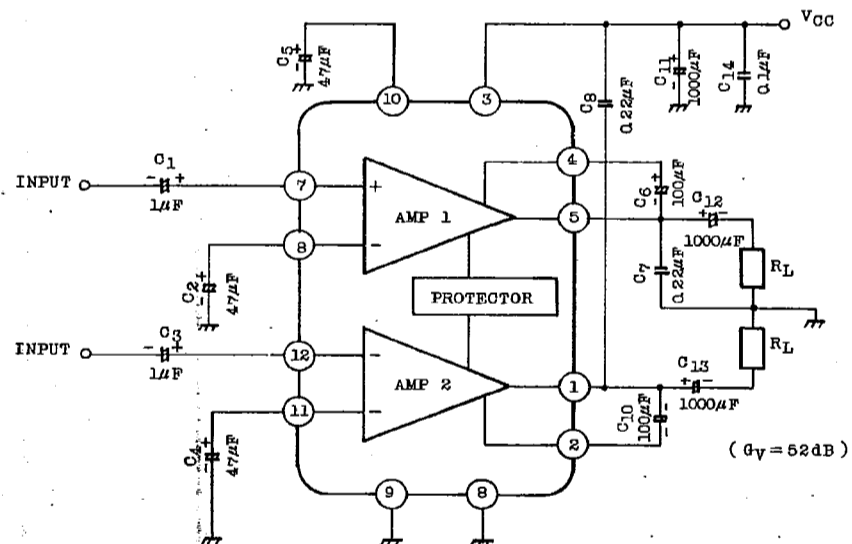

TOSHIBA

TA7270P
TA7271P
T-74-05-01

TYPICAL DC VOLTAGE OF EACH TERMINAL

(V_{CC}=13.2V, T_a=25°C, DUAL MODE TEST CIRCUIT)

TERMINAL No.	1	2	3	4	5	6	7	8	9	10	11	12	
DC Voltage (V)	TA7270P	1.5	1.5	4.4	GND	1.5	1.5	GND	6.6	12.7	V _{CC}	12.7	6.6
	TA7271P	6.6	12.7	V _{CC}	12.7	6.6	GND	1.5	1.5	GND	4.4	1.5	1.5

APPLICATION INFORMATION

(This explanatory terminal number is for TA7270P)

1. VOLTAGE GAIN

(1) Dual Mode

The closed loop voltage gain G_v is determined by R₁, R₂, R₃, R₄ and R_f.

$$G_v = 20 \log \frac{R_2 + R_f + R_1}{R_f + R_1} + 20 \log \frac{R_3 + R_4}{R_4} \text{ (dB)}$$

when R_f=0, G_v=52dB(Typ.)

is given.

The recommended voltage gain is more than 40dB.

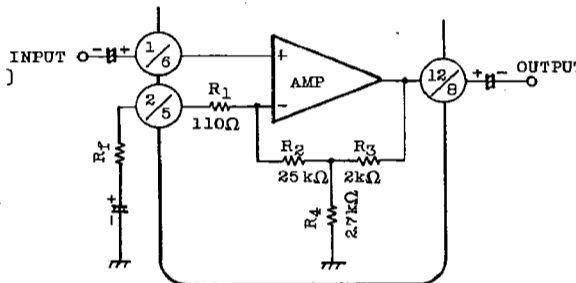

Fig. 1

(2) BTL Mode

The recommended BTL connection amplifier is shown in Figure 2.

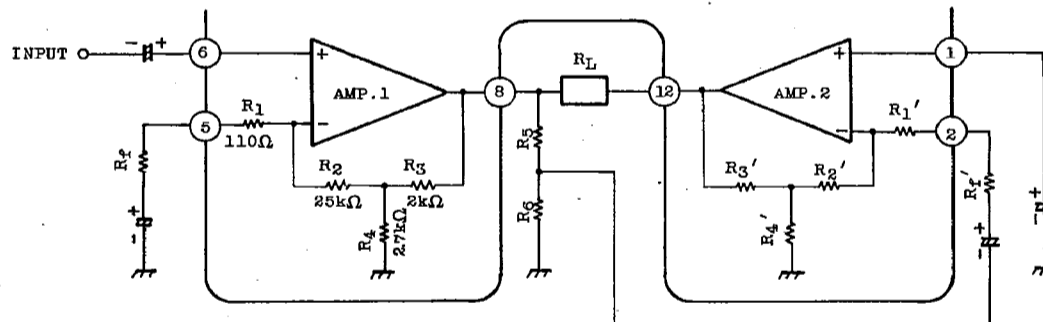

Fig. 2

TA7270P
TA7271P

T-74-05-01

AMP.1 is noninverting amplifier and AMP.2 is inverting one. The output voltage is divided by resistors R₅ and R₆. This divided voltage is applied to inverting input of AMP.2. R₅ and R₆ are determined in the following equation.

$$\frac{R_5+R_6}{R_5} = 20 \log \frac{R_1+R_f+R_2}{R_1+R_f} + 20 \log \frac{R_3+R_4}{R_4} \dots \dots G_v \text{ in Dual Mode}$$

The voltage gain in this circuit is 6dB higher than that in dual mode.

$$G_v = 20 \log \frac{R_1+R_f+R_2}{R_1+R_f} + 20 \log \frac{R_3+R_4}{R_4} + 6 \quad (\text{dB})$$

In case of R_f=0

$$G_v = 52+6=58(\text{dB})$$

In case of R_f=750Ω

$$G_v = 34+6=40(\text{dB})$$

2. MUTING

Audio muting can be accomplished by connecting pin ③ (ripple filter) to GND as shown in Fig.3. Then, the bias circuits are cut off.

Amount of muting attenuation is more than 60dB. Precaution in muting operation is as follows.

- (1) The recovery time at muting off depends on Capacitance C₂, C₄ and C₅ in the test Circuit.
- (2) As this muting system is operated by the short-circuit of ripple filter : C₅, the ripple rejection ratio becomes worse in a muting mode. Note that some "POP-Noise" occur when bias is shut off with mute-on.

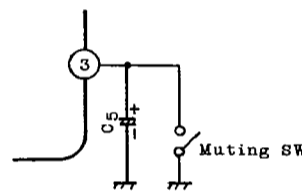

Fig.3

3. CAPACITOR C₇, C₈

The purpose of capacitor C₇, C₈ is to prevent oscillation.

These capacitors need to be small temperature coefficient. So celamic capacitor is unsuitabel.

A voltage gain less than 40dB results occasionally in a parastic oscillation.

Stability for parastic oscillation is promoted by connecting capacitor of 500~1000pF between pin ① and pin ② (pin ⑤ and pin ⑥).

The additional capacitors are recommended to be inserted.

TOSHIBA

TA7270P

TA7271P

T-74-05-01

4. PRECAUTION AT PRINT BOARD DESIGN

- (1) Print Pattern board should be designed in consideration of stability for parastic oscillation.

The following parts-layout is recommended.

- 1st. Capacitors C6 and C10 are spaced most close to the output pin.
 - 2nd. Capacitor C7 or C8 is spaced close to the output pin next to C6 and C10.
 - 3rd. Capacitor C9 is spaced close to it next to C7 and C8.
 - 4th. Capacitor C11 is spaced close to it next to C9.
- (2) Input line (pin ⑥) and PW-GND line (pin ⑦) should not be spaced in parallel. In the paralled layout, output current signal in PW-GND line is bed back to input line by electromagnetic coupling. Then it deteriorates the total harmonic distortion, especially at high audio frequency region.
- (3) Undesirable terminating of capacitors deteriorates "pop" noise or THD. Capacitors C2, C4 and C5 should be terminated to Pre-GND (pin ④). Capacitors C7, C11, and C14 should be terminated to PW-GND (pin ⑦).
- (4) It is recommended to refer the standard print board.

AUDIO LINEAR IC

TA7270P
TA7271P

T-74-05-01

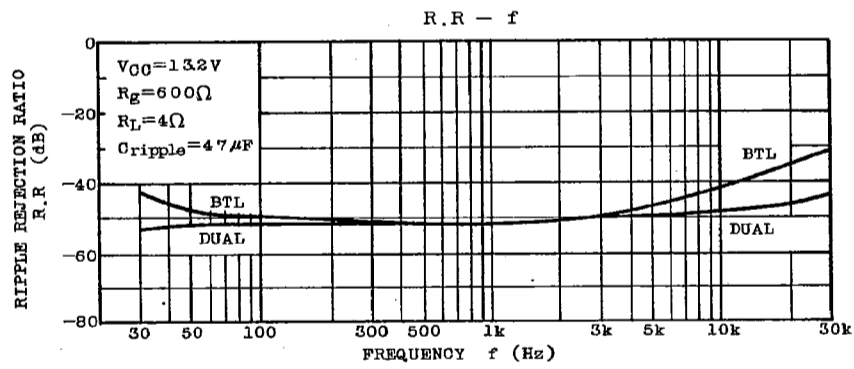
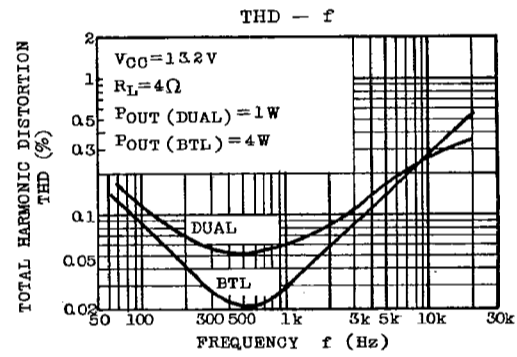
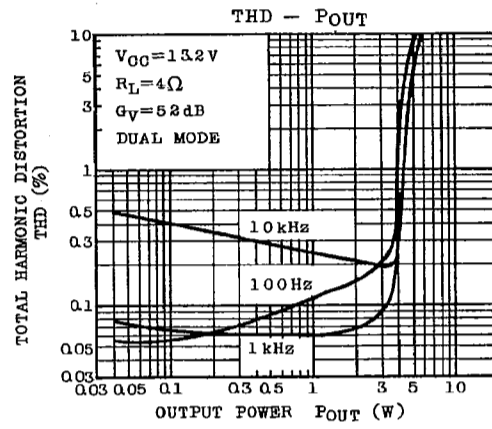
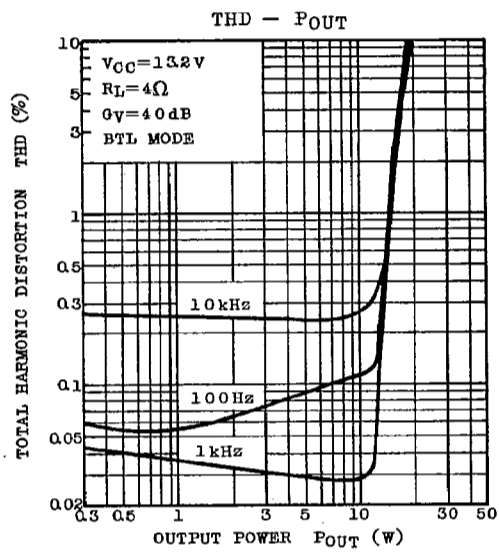

TOSHIBA

TA7270P

TA7271P

T-74-05-01

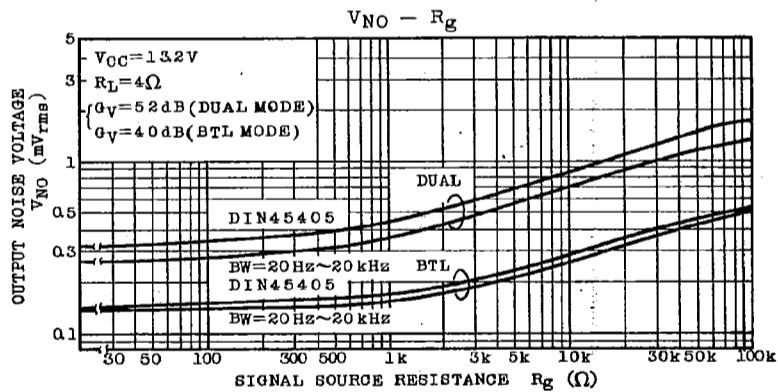
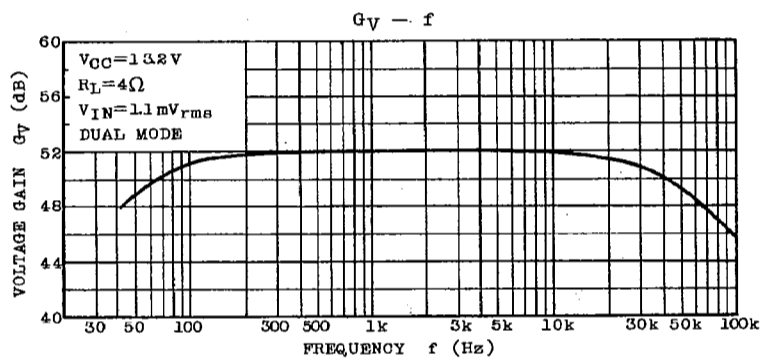
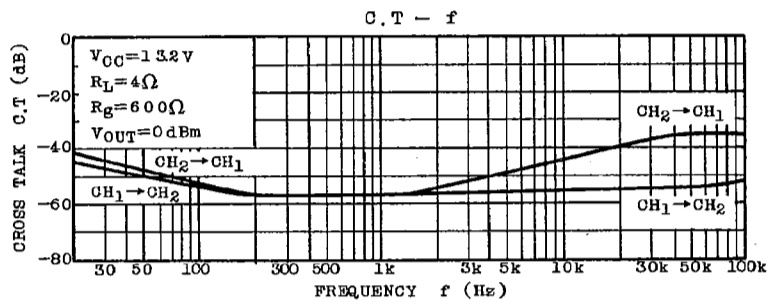

AUDIO LINEAR IC

TA7270P
TA7271P

T-74-05-01

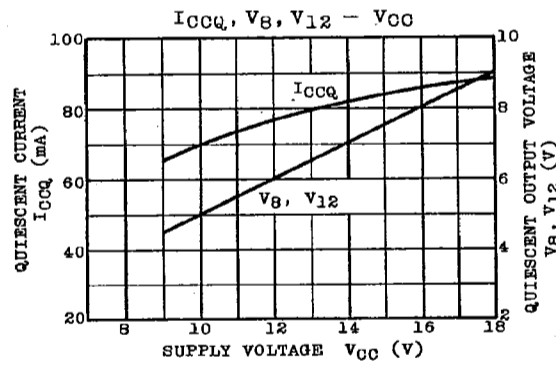
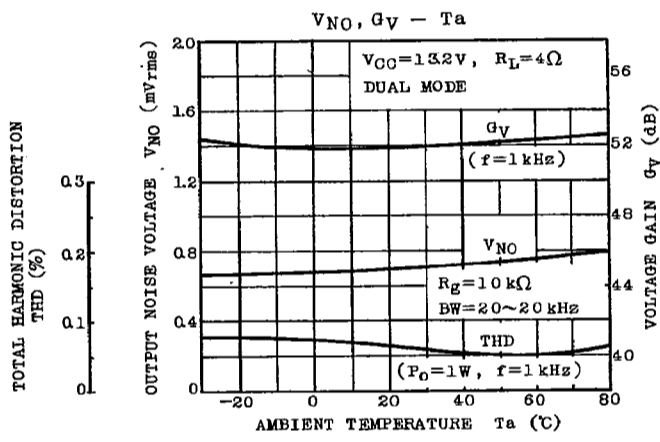
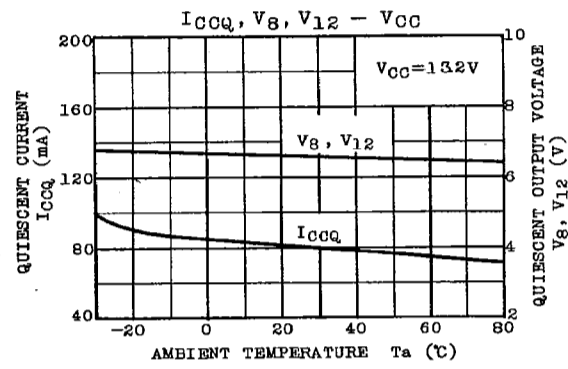

TA7270P
TA7271P

T-74-05-01

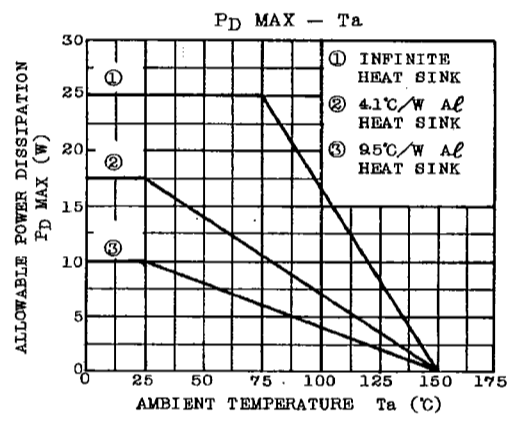
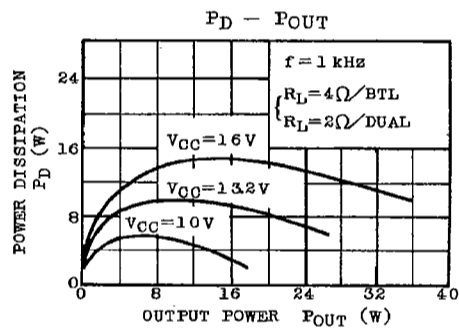
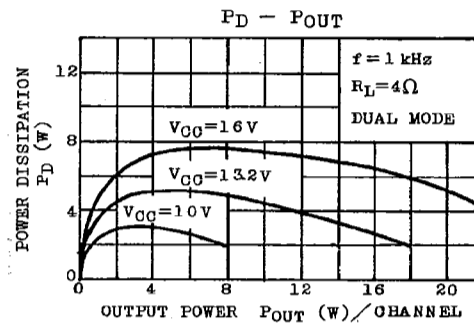
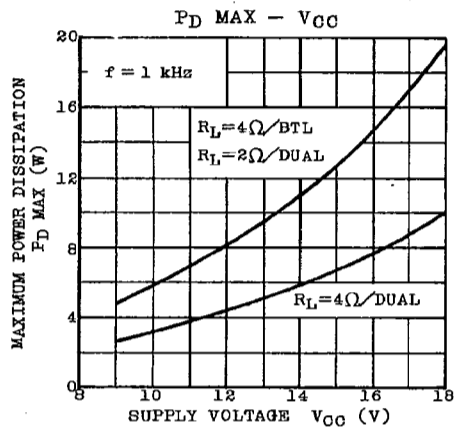

AUDIO LINEAR IC