

TENTATIVE DATA

FILTER IC FOR NICAM

The TA2047F is an analog filter IC for NICAM. Using the TA2047F in combination the TB1212F (Single Chip NICAM System), it is possible to construct a NICAM decoder system with less external parts.

FEATURES

- Built-in CR for LPFs and output (differential) amplifiers for the left and right channel.
- Built-in audio SW and possible to FM signal input dynamic range up. ($V_{CC}=9V$)
- It is possible to apply an analog de-emphasis circuit.
- $2V_{rms}$ output. ($V_{CC}=9V$)
- 6dB up SW. (9V operation)
- Built-in analog mute circuit.
- 9V power supply operation. (5V, 12V possible)

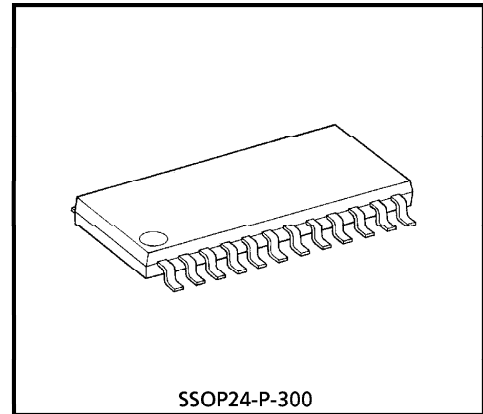

SSOP24-P-300

Weight : 0.32g (Typ.)

BLOCK DIAGRAM

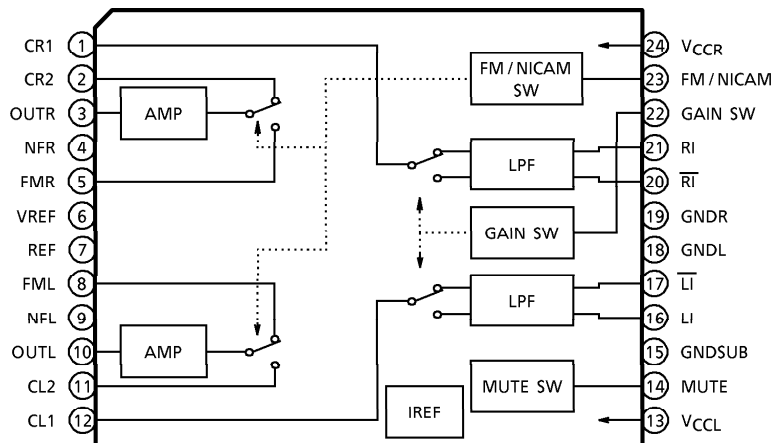

© The information contained herein is presented only as a guide for the applications of our products. No responsibility is assumed by TOSHIBA CORPORATION for any infringements of intellectual property or other rights of the third parties which may result from its use. No license is granted by implication or otherwise under any intellectual property or other rights of TOSHIBA CORPORATION or others.

© These TOSHIBA products are intended for use in general commercial applications (office equipment, communication equipment, measuring equipment, domestic appliances, etc.). please make sure that you consult with us before you use these TOSHIBA products in equipment which requires extraordinarily high quality and/or reliability, and in equipment which may involve life threatening or critical application, including but not limited to such uses as atomic energy control, airplane or spaceship instrumentation, traffic signals, medical instrumentation, combustion control, all types of safety devices, etc. TOSHIBA cannot accept and hereby disclaims liability for any damage which may occur in case the TOSHIBA products are used in such equipment or applications without prior consultation with TOSHIBA.

TERMINAL CONNECTION

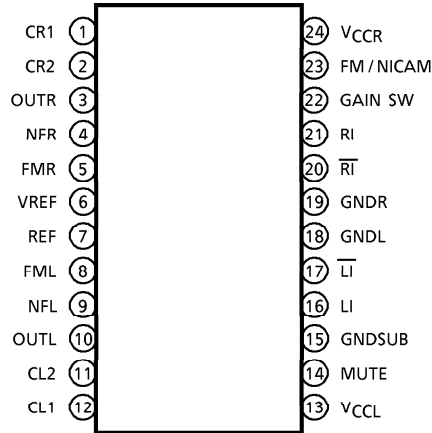

TERMINAL FUNCTION

Terminal list (Pin 24 FP)

PIN No.	PIN NAME	I/O	FUNCTION
1	CR1	O	R channel LPF input terminal.
2	CR2	I	R channel FM / NICAM select Amp. forward input terminal. (NICAM)
3	OUTR	O	R channel FM / NICAM select Amp. output terminal.
4	NFR	I	R channel FM / NICAM select Amp. reverse input terminal.
5	FMR	I	R channel FM / NICAM select Amp. forward input terminal. (FM)
6	VREF	O	1/2 V _{CCR} reference voltage output terminal.
7	REF	—	(to be open)
8	FML	I	L channel FM / NICAM select Amp. forward input terminal. (FM)
9	NFL	I	L channel FM / NICAM select Amp. reverse input terminal.
10	OUTL	O	L channel FM / NICAM select Amp. output terminal.
11	CL2	I	L channel FM / NICAM select Amp. forward input terminal (NICAM)
12	CL1	O	L channel LPF input terminal.
13	V _{CCL}	—	L channel power supply.
14	MUTE	I	MUTE control signal input terminal. (L : MUTE OFF, H : MUTE ON)
15	G \bar{NDSUB}	—	GND
16	LI	I	L channel forward input terminal.
17	L \bar{I}	I	L channel reverse input terminal.
18	G \bar{NDL}	—	L channel GND.
19	G \bar{NDR}	—	R channel GND.
20	R \bar{I}	I	R channel reverse input terminal.
21	RI	I	R channel forward input terminal.
22	GAIN SW	I	Gain control. (L : +0dB, H : +6dB)
23	FM / NICAM	I	FM / NICAM select terminal. (L : FM, H : NICAM)
24	V _{CCR}	—	R channel power supply.

TERMINAL INTERFACE CIRCUIT

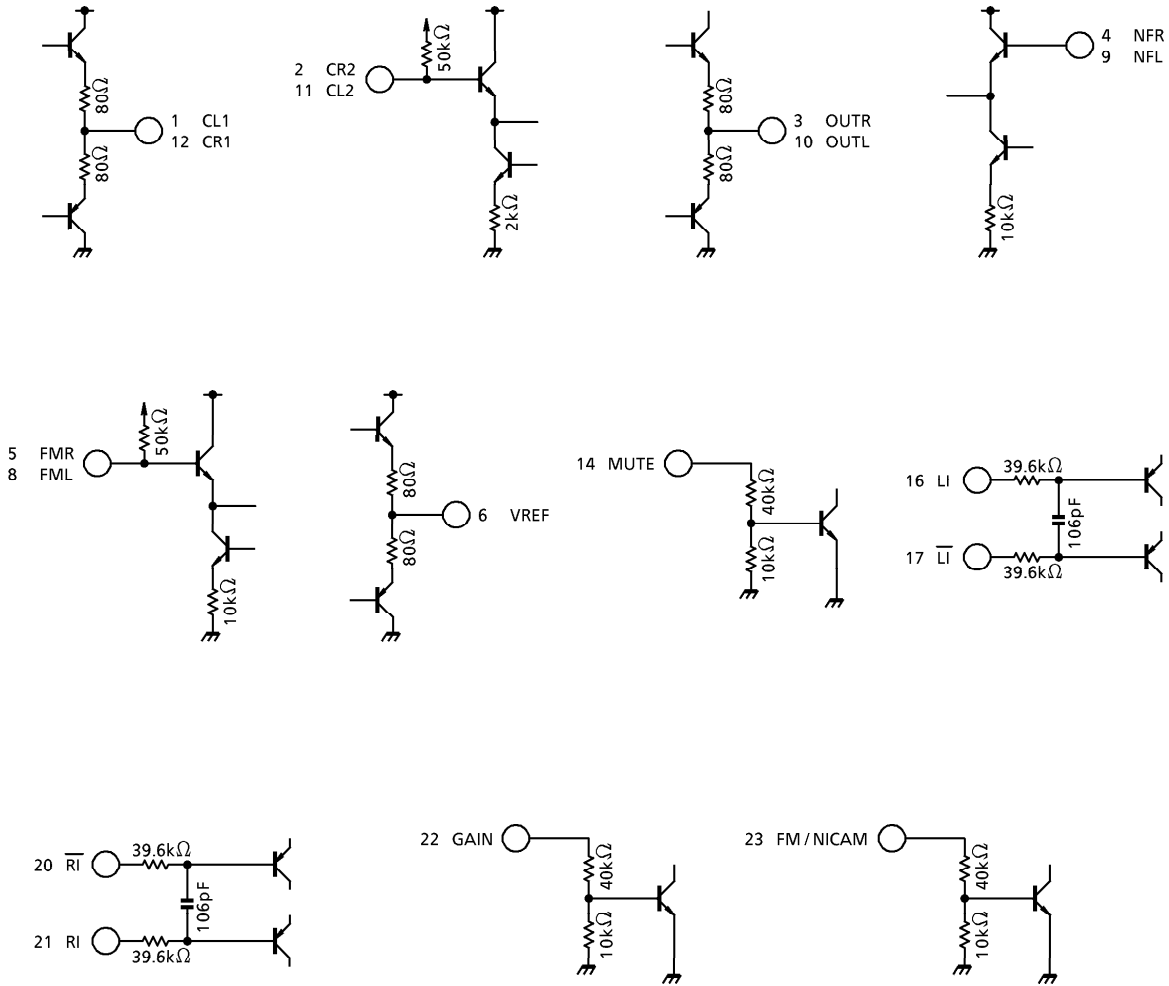

MAXIMUM RATINGS (Ta = 25°C)

CHARACTERISTIC	SYMBOL	RATING	UNIT
Supply Voltage	V _{CC}	12.6	V
Storage Temperature	T _{stg}	-55~150	°C
Power Dissipation	P _D (Note)	400	mW

(Note) When using the device at above Ta = 25°C, decrease the power dissipation by 10.4mW for each increase of 1°C.

RECOMMENDABLE OPERATING CONDITION

CHARACTERISTIC	SYMBOL	TEST CONDITION	MIN.	TYP.	MAX.	UNIT
Supply Voltage	V _{CC}	—	4.5	—	12.6	V
Operating Temperature	T _{opr}	—	-25	—	65	°C

ELECTRICAL CHARACTERISTICS (tentative)

(Unless otherwise specified, V_{CC} = 9V, 1/2V_{DD} = 2.5V, OSC1 = OSC2 = 1.17V_{rms} (1kHz)
SW₁~SW₈ = a, 400Hz HPF, 30kHz LPF, Ta = 25°C)

CHARACTERISTIC	SYMBOL	TEST CIR-CUIT	TEST CONDITION	MIN.	TYP.	MAX.	UNIT
Consumption Current	I _{CCQ}	—	SW ₁ = SW ₂ = b	11.6	15.6	21.0	mA
Noise Distortion Factor	THD + N	—	—	—	-79	-74	dB
S/N	S/N	—	—	82	86	—	dB
Gain	G _V	—	OSC1 = 460mV _{rms}	2.60	4.24	—	dB
Gain (15k)	G _V (15k)	—	f = 15kHz, OSC1 = 460mV _{rms}	1.25	3.45	—	dB
Gain (70k)	G _V (70k)	—	f = 70kHz, OSC1 = 460mV _{rms}	—	-31.0	-12.7	dB
Gain (UK)	G _V (UK)	—	SW ₄ = b, OSC1 = 230mV _{rms}	8.6	10.28	—	dB
Cross Talk	CT	—	SW ₂ = b (L-ch→R-ch), SW ₁ = b (R-ch→L-ch)	—	-85.0	-80.8	dB
High Level Input Voltage (1)	*1 G _V V _{th} (H)	—	—	4.0	—	—	V
Low Level Input Voltage (2)	*1 G _V V _{th} (L)	—	—	—	—	1.0	V
High Level Input Voltage (3)	*2 F/N V _{th} (H)	—	—	4.0	—	—	V
Low Level Input Voltage (4)	*2 F/N V _{th} (L)	—	—	—	—	1.0	V
High Level Input Voltage (5)	*3 Mu V _{th} (H)	—	—	4.0	—	—	V
Low Level Input Voltage (6)	*3 Mu V _{th} (L)	—	—	—	—	1.0	V

*1 For GAIN SW (pin 22)

*2 For FM/NICAM (pin 23)

*3 For MUTE (pin 14)

TEST CIRCUIT

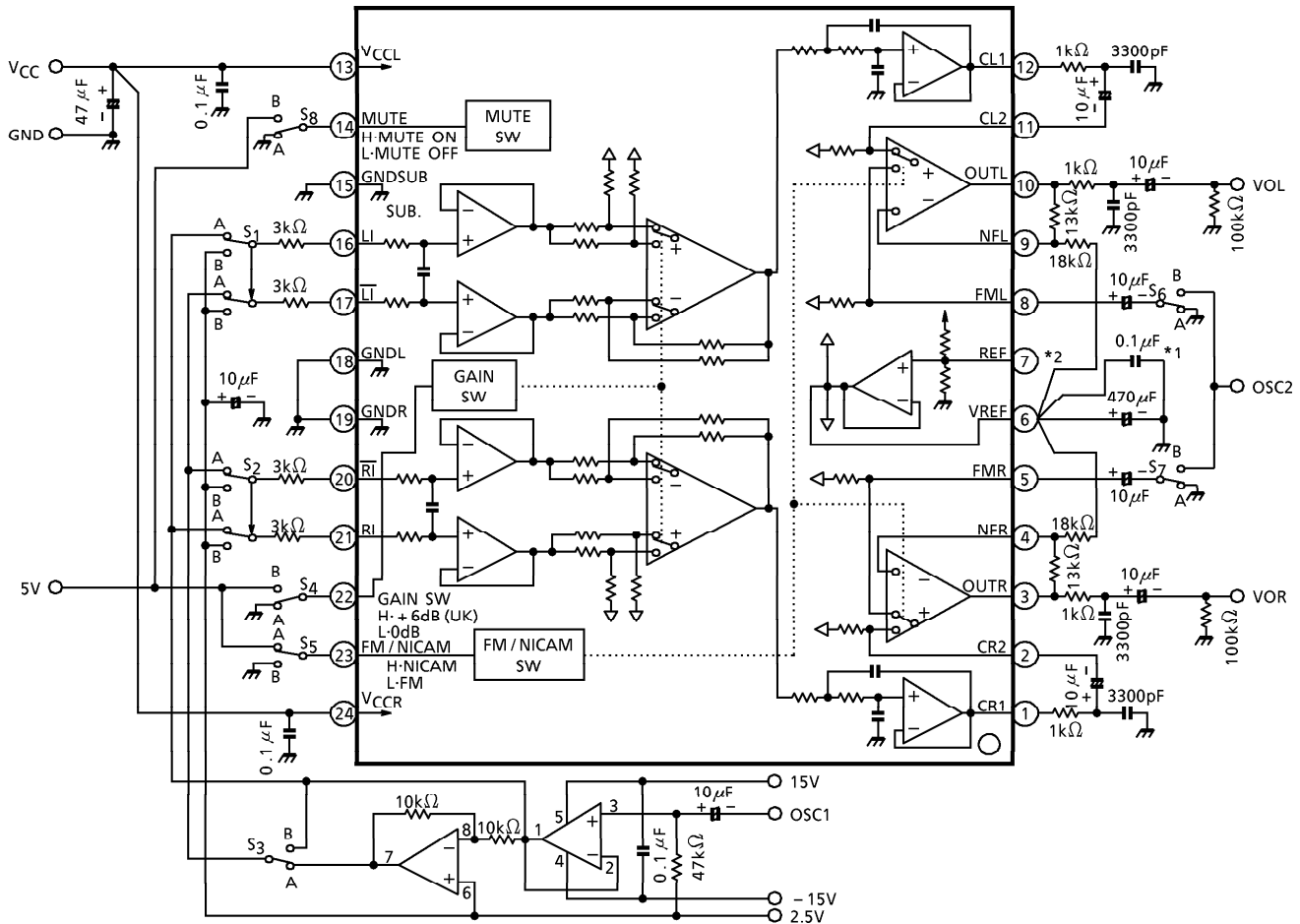

- (Note 1) It is require to connect ceramic or film condenser not to receive temperature characteristics.
- (Note 2) Pin 7 to be open. (Don't connect to GND or V_{CC}).
- (Note 3) It is require to other wring GND line of pin 18, 19 and 15.
- (Note 4) C24 connect between pin 6 and 15.

APPLICATION CIRCUIT 1
(Digital De-emphasis $V_{CC} = 9V$)

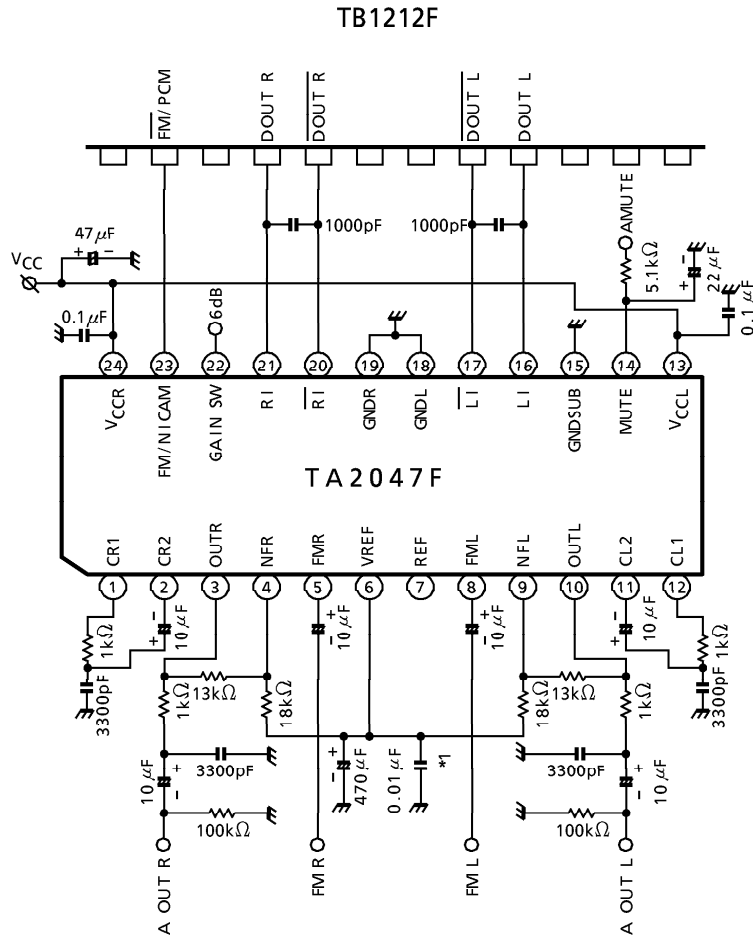

- (Note 1) It is require to connect ceramic or film condenser not to receive temperature characteristics. (*1)
- (Note 2) Pin 7 to be open. (Don't connect to GND or V_{CC})
- (Note 3) It is require to other wiring GND line of pin 18, 19 and 15.
- (Note 4) C24 connect between pin 6 and 15.

APPLICATION CIRCUIT 2
(Analog De-emphasis $V_{CC} = 9V$)

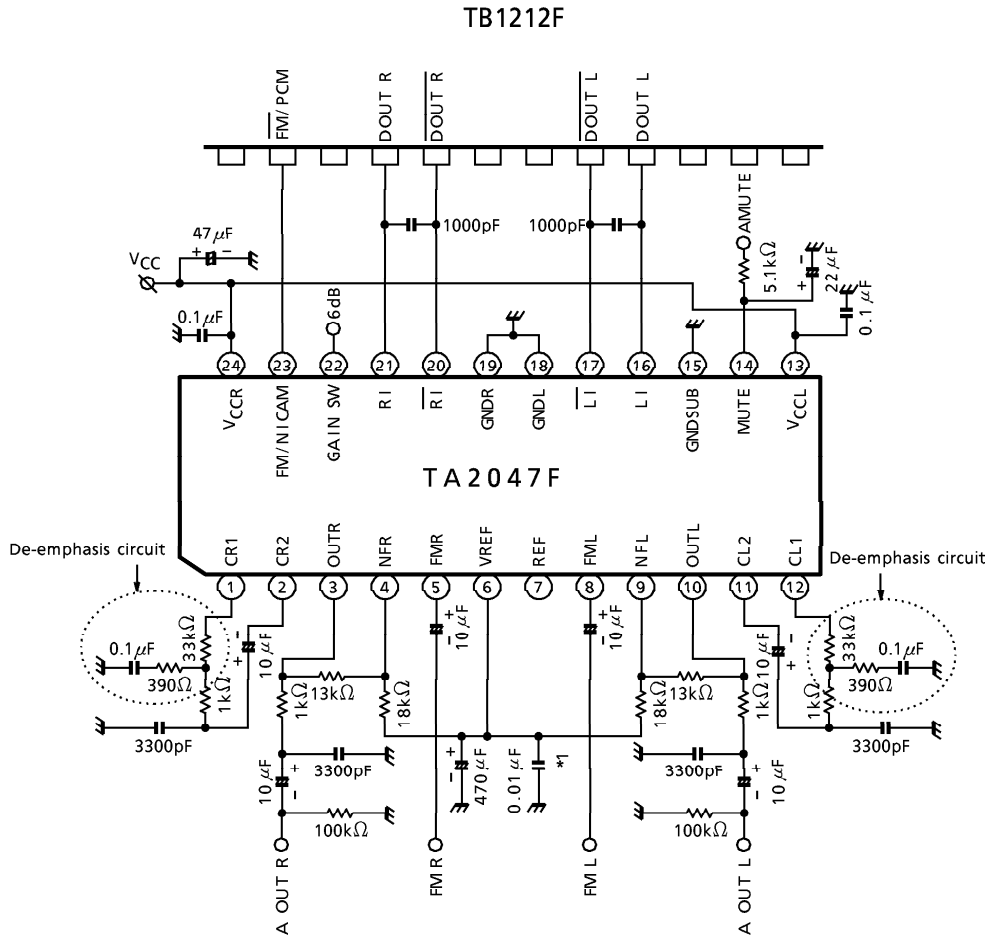

- (Note 1) It is require to connect ceramic or film condenser not to receive temperature characteristics. (*1)
- (Note 2) Pin 7 to be open. (Don't connect to GND or V_{CC})
- (Note 3) It is require to other wiring GND line of pin 18, 19 and 15.
- (Note 4) C24 connect between pin 6 and 15.

OUTLINE DRAWING
SSOP24-P-300

Unit : mm

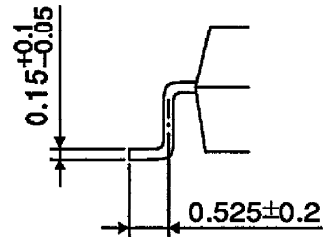
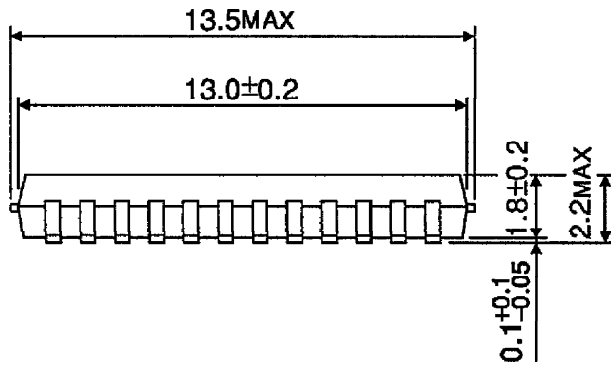
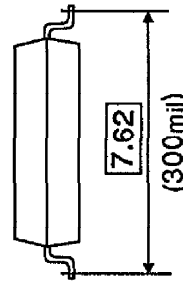
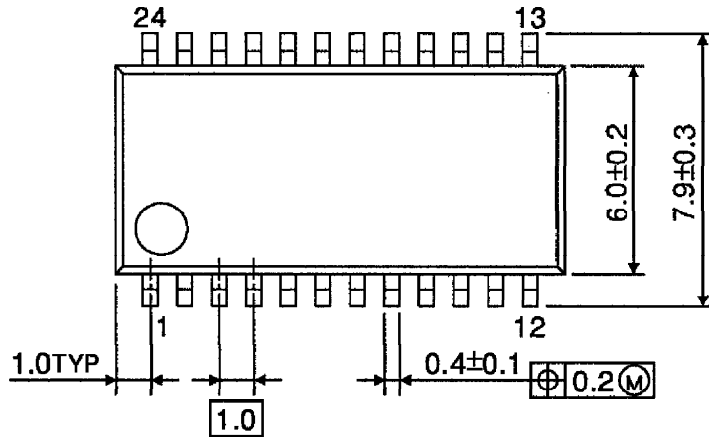

Weight : 0.32g (Typ.)