

TA2041F

SOUND FIELD REPRODUCTION IC

The TA2041F is sound field reproduction IC developed for stereo audio equipment as radio cassette and music center.

This IC has made it possible to reproduce stereo phonic sound with more presence by forcing difference signals of R-ch and L-ch to delay and applying these signals to R-ch and L-ch again.

FEATURES

- Dual Channel
- 3-type surround mode and normal mode are available
- Built-in mode switch
- Built-in EXT-IN terminal
- Operating Supply Voltage Range : $V_{CC}(\text{opr.}) = 4.0 \sim 12.0\text{V}$ ($T_a = 25^\circ\text{C}$)

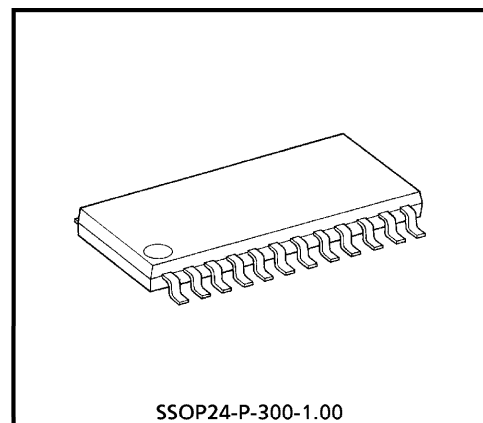

Weight : 0.31g (Typ.)

BLOCK DIAGRAM

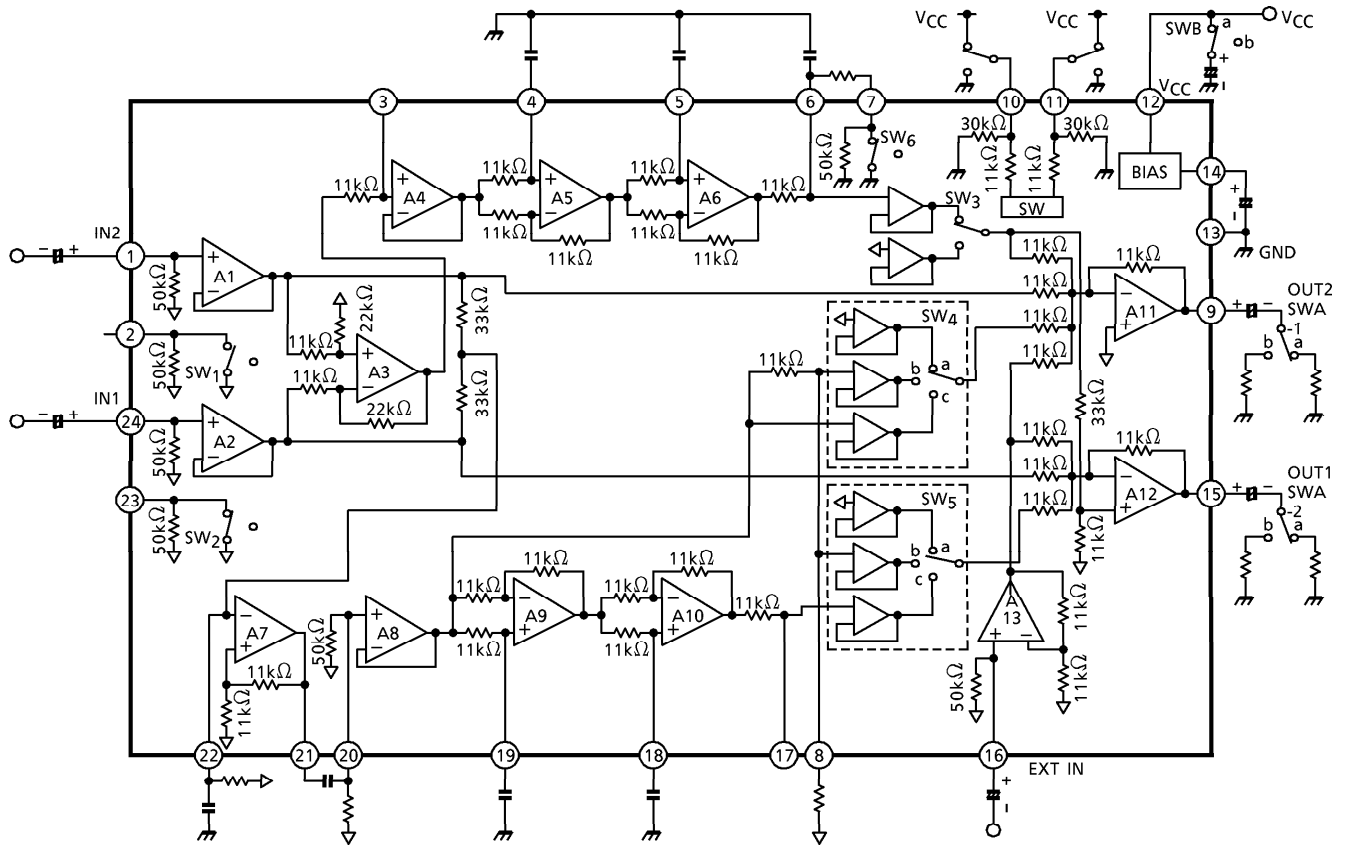

TERMINAL EXPLANATION

TERMINAL NAME	SYMBOL	CONTENTS	EQUIVALENT CIRCUIT
1	IN1	Input terminal	
24	IN2		
2	LF IN2	Low pass filter switch	
23	LF IN1		
3	LF1	Low pass filter	
4	PS1	(L - R) signal delay time constant	
5	PS2		
19	PS3	(L + R) signal delay time constant	
18	PS4		

TERMINAL NAME	SYMBOL	CONTENTS	EQUIVALENT CIRCUIT
6	LF2	(L - R) low pass filter	
17	LF5	(L + R) low pass filter	
7	MIX LEVEL1	(L - R) mixing level adjustment	
8	MIX LEVEL2	(L + R) mixing level adjustment	
15	OUT1	Output terminal	
9	OUT2		

TERMINAL NAME	SYMBOL	CONTENTS	EQUIVALENT CIRCUIT
10	SW A	Mode select switch	
11	SW B		
12	VCC	VCC terminal	—
13	GND	GND terminal	—
14	Vref	Reference voltage	
16	EXT IN	External input	
20	LF4	(L + R) low pass filter input	

TERMINAL NAME	SYMBOL	CONTENTS	EQUIVALENT CIRCUIT
21	LF3	(L + R) low pass filter output	
22	HF1	(L + R) high pass filter	

MAXIMUM RATINGS (Ta = 25°C)

CHARACTERISTIC	SYMBOL	RATING	UNIT
Supply Voltage	V _{CC}	14	V
Power Dissipation (Note)	P _D	400	mW
Operating Temperature	T _{opr}	- 25~75	°C
Storage Temperature	T _{stg}	- 55~150	°C

(Note) Derated above 25°C in the proportion of 3.2mW/°C for TA2041F.

ELECTRICAL CHARACTERISTICS (Unless otherwise specified, $V_{CC} = 9V$, $f = 1kHz$, $R_L = 10k\Omega$, $T_a = 25^\circ C$, NORMAL MODE)

CHARACTERISTIC	SYMBOL	TEST CIRCUIT	TEST CONDITION	MIN.	TYP.	MAX.	UNIT
Quiescent Current	I_{CCQ}	—	$V_{in} = 0$	—	10	14.0	mA
Voltage Gain	G_{V1}	—	$V_{out} = 1V_{rms}$ (0dBV)	-2	0	2	dB
Gain Tacking	ΔG_V	—	$V_{out} = 1V_{rms}$ (0dBV)	-1	0	1	dB
Voltage Gain	G_{V2}	—	SURROUND1 MODE, $f = 100Hz$	4.5	6.5	8.5	dB
	G_{V3}	—	SURROUND2 MODE, $f = 100Hz$	-2	0	2	dB
	G_{V4}	—	SURROUND3 MODE, $f = 100Hz$	7	9	11	dB
Maximum Output Voltage	V_{om}	—	THD = 1%, $R_L = 4.7k\Omega$	1.8	2.2	—	V_{rms}
Total Harmonic Distortion	THD	—	$V_{out} = 300mV_{rms}$	—	0.02	0.1	%
Output Noise Voltage	V_{no1}	—	NORMAL MODE, $BW = 400\sim 30kHz$	—	12	20	μV_{rms}
	V_{no2}	—	SURROUND1 MODE, $BW = 400\sim 30kHz$	—	13	22	μV_{rms}
	V_{no3}	—	SURROUND2 MODE, $BW = 400\sim 30kHz$	—	13	22	μV_{rms}
	V_{no4}	—	SURROUND3 MODE, $BW = 400\sim 30kHz$	—	15	25	μV_{rms}
Channel Separation	Sep.	—	$V_{out} = 1V_{rms}$	-50	-58	—	dB
Ripple Rejection Ratio	R.R	—	$f = 100Hz$, $V_{ripple} = -10dB$, $SWB = B$	—	-46	—	dB
Input Resistance	R_{IN}	—	—	—	50	—	$k\Omega$
Mode Switch Control Voltage	$V_{TH}(H)$	—	$V_{TH} L \rightarrow H$	—	1.2	1.7	V
	$V_{TH}(L)$	—	$V_{TH} H \rightarrow L$	0.7	1.2	—	V

SWITCH POSITION

MODE	CONTROL TERMINAL		BUILT-IN SWITCH					
	D1	D2	SW1	SW2	SW3	SW4	SW5	SW6
NORMAL	L	L	0	0	0	a	a	1
SURROUND1	L	H	1	1	1	b	b	1
SURROUND2	H	L	1	1	0	c	c	0
SURROUND3	H	H	1	1	1	c	c	0

TEST CIRCUIT

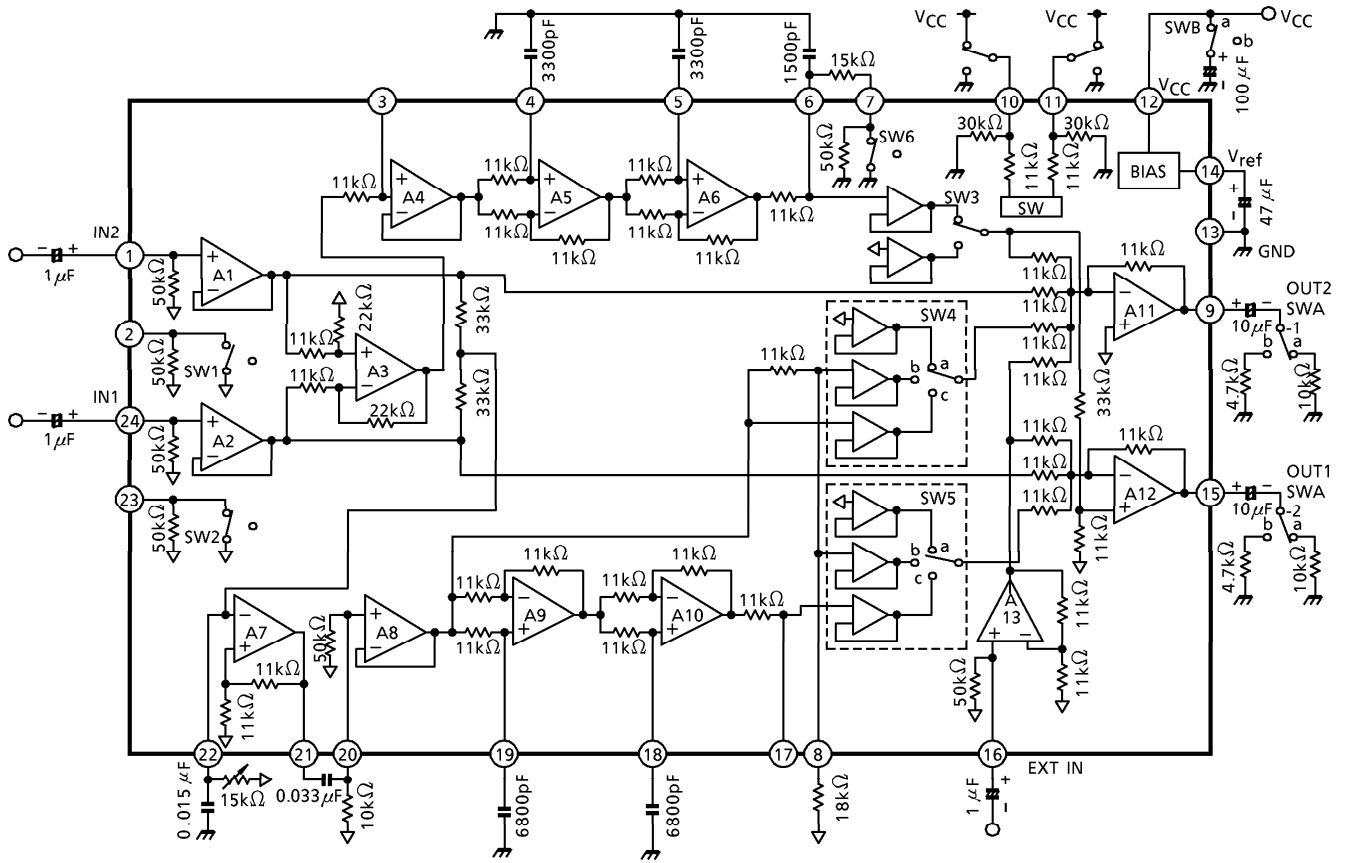

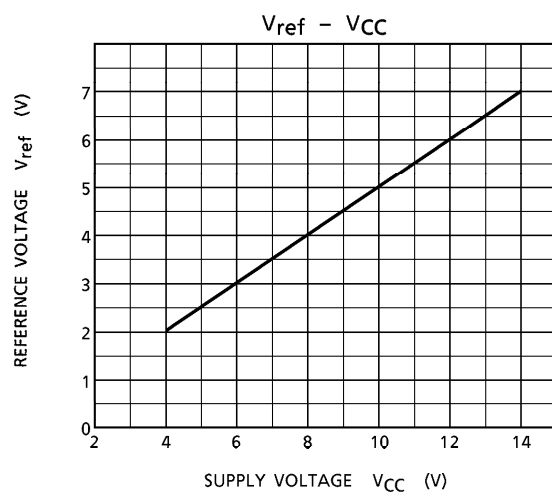
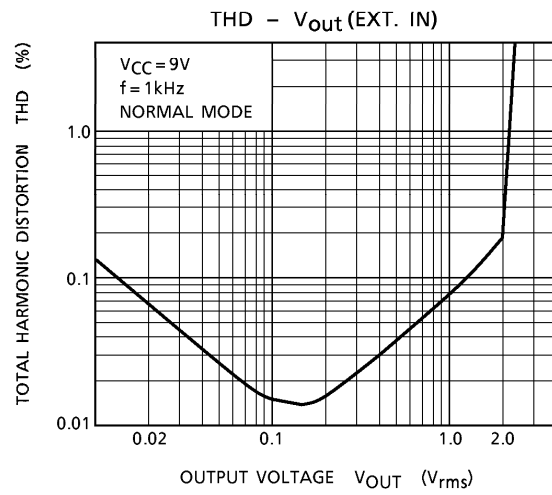
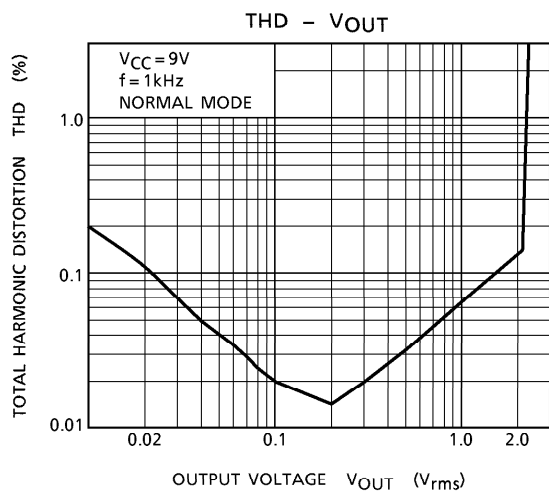
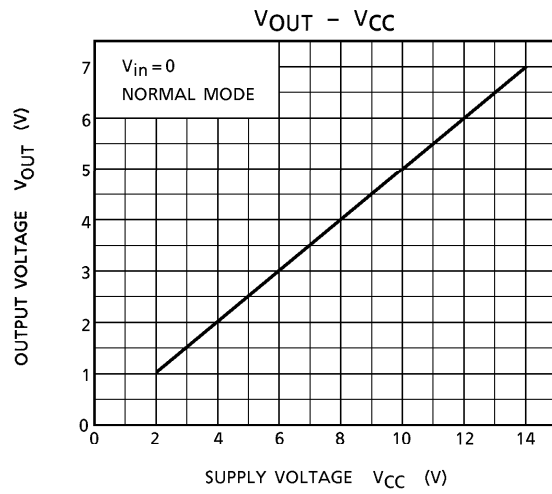
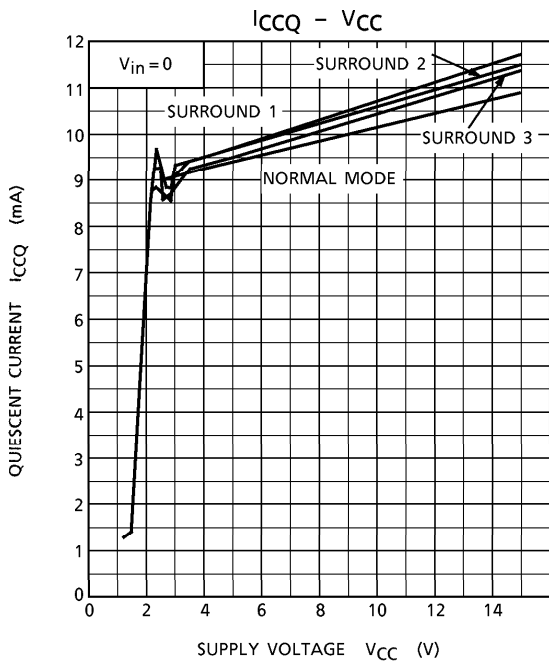

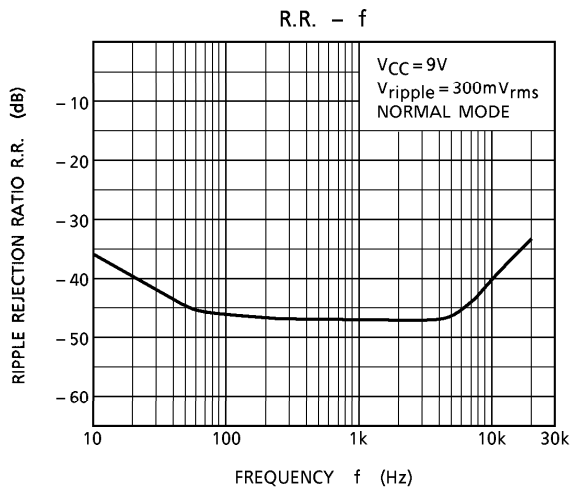
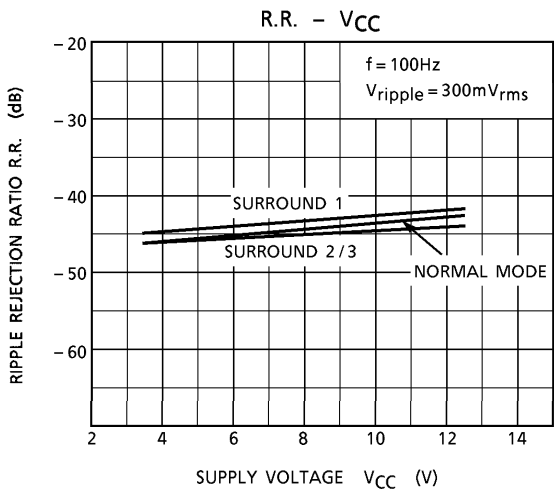
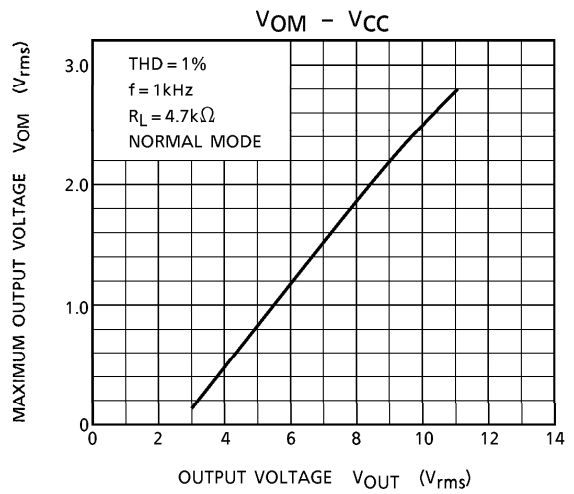
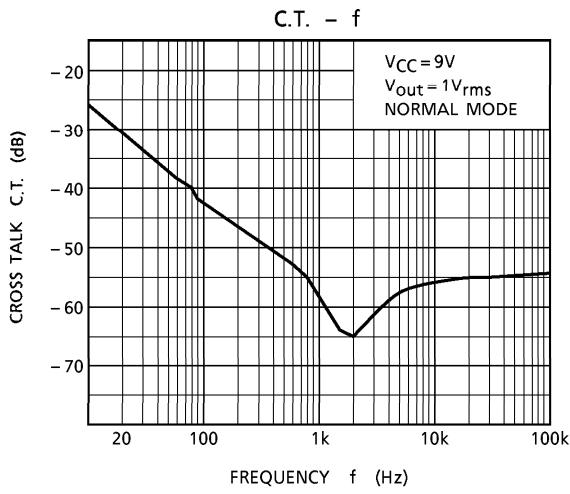

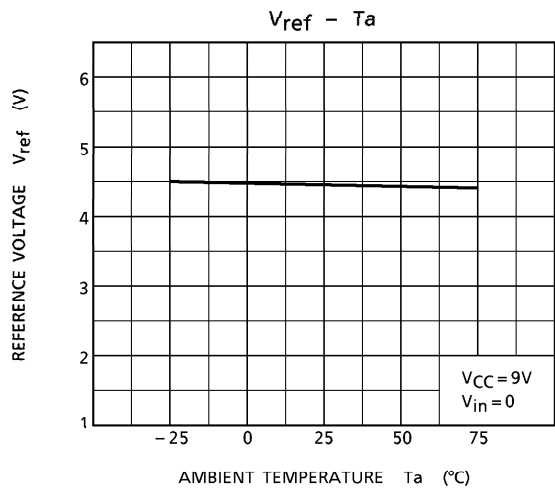
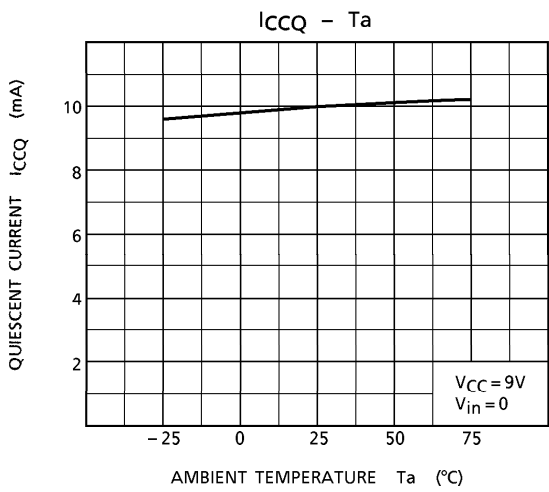
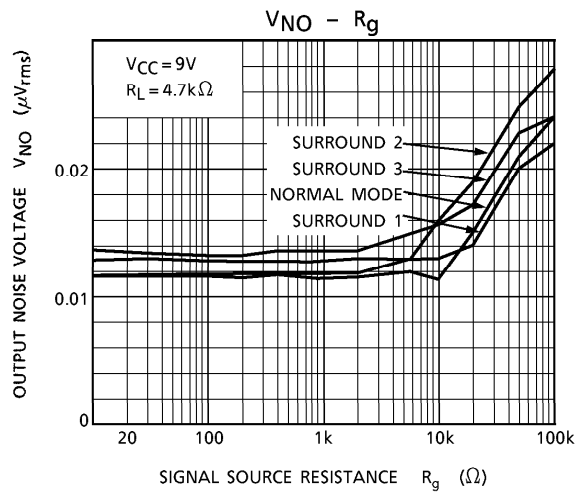
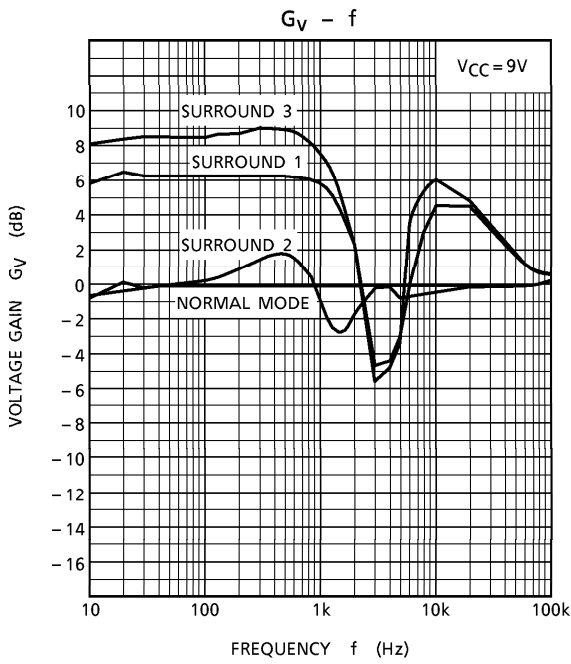

APPLICATION CIRCUIT

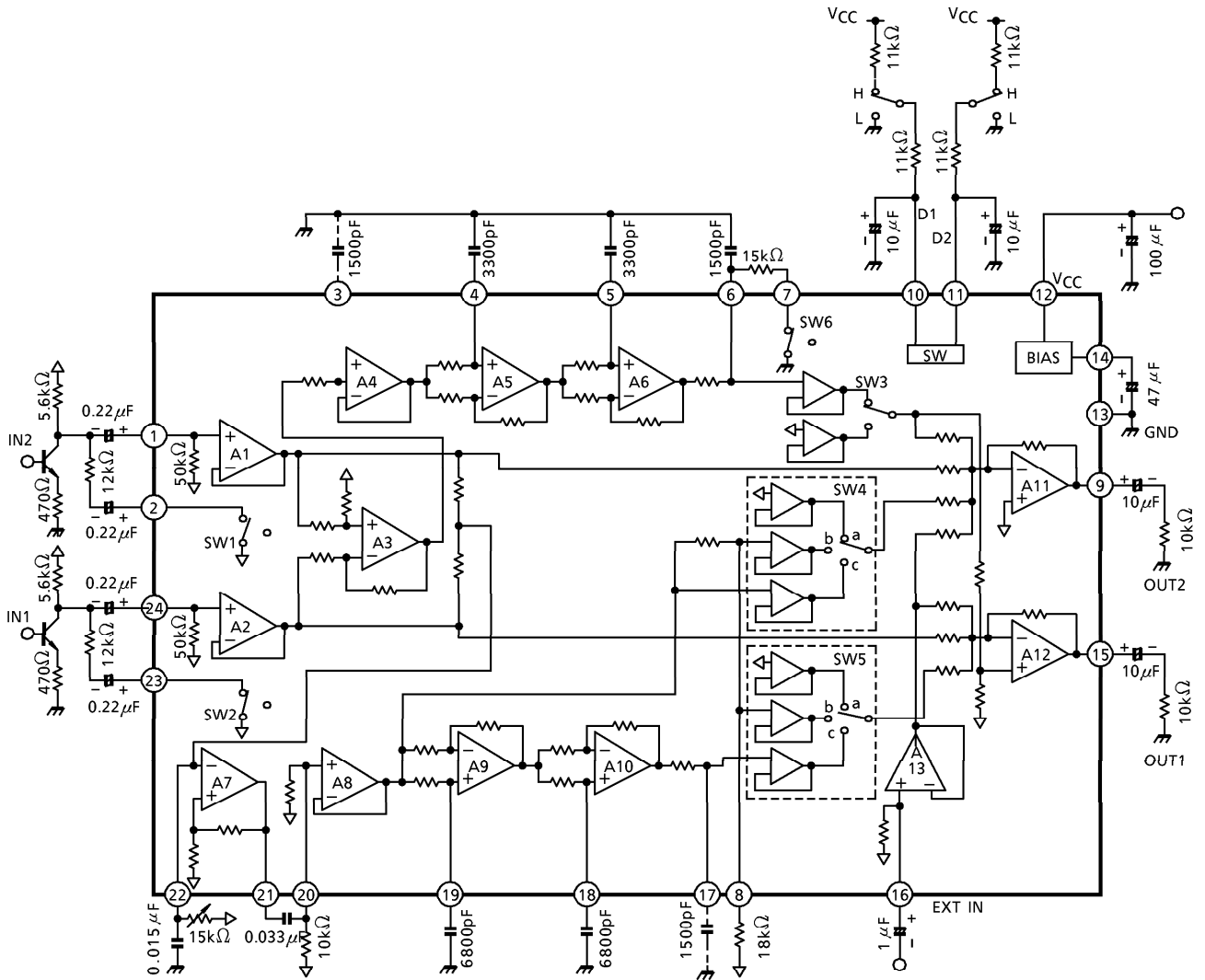

PACKAGE DIMENSIONS
SSOP24-P-300-1.00

Unit : mm

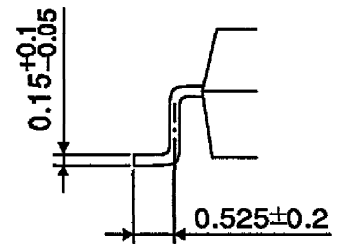
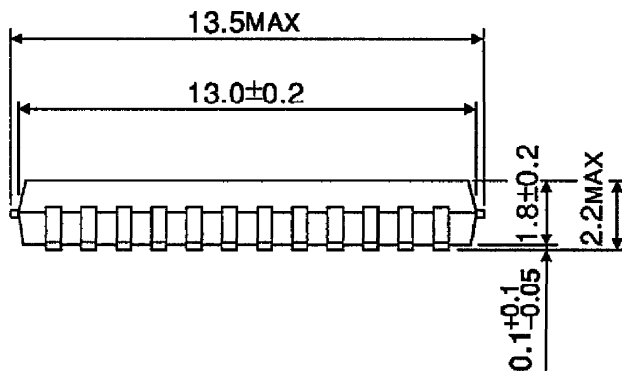
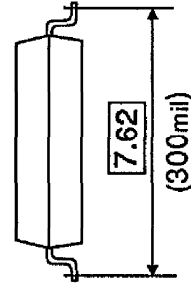
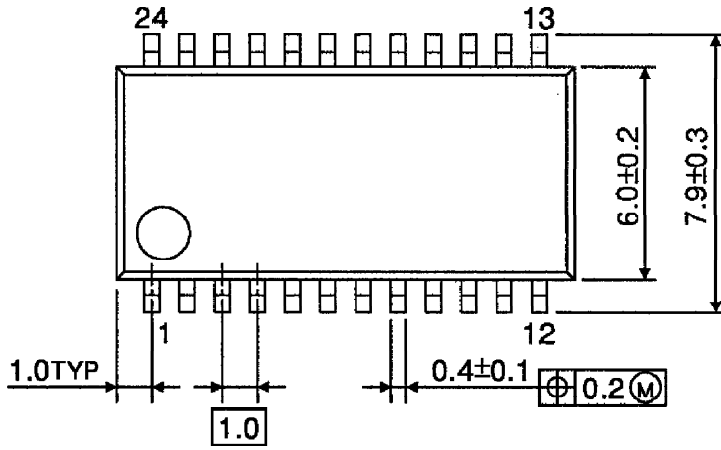

Weight : 0.31g (Typ.)

RESTRICTIONS ON PRODUCT USE

000707EBA

- TOSHIBA is continually working to improve the quality and reliability of its products. Nevertheless, semiconductor devices in general can malfunction or fail due to their inherent electrical sensitivity and vulnerability to physical stress. It is the responsibility of the buyer, when utilizing TOSHIBA products, to comply with the standards of safety in making a safe design for the entire system, and to avoid situations in which a malfunction or failure of such TOSHIBA products could cause loss of human life, bodily injury or damage to property. In developing your designs, please ensure that TOSHIBA products are used within specified operating ranges as set forth in the most recent TOSHIBA products specifications. Also, please keep in mind the precautions and conditions set forth in the "Handling Guide for Semiconductor Devices," or "TOSHIBA Semiconductor Reliability Handbook" etc..
- The TOSHIBA products listed in this document are intended for usage in general electronics applications (computer, personal equipment, office equipment, measuring equipment, industrial robotics, domestic appliances, etc.). These TOSHIBA products are neither intended nor warranted for usage in equipment that requires extraordinarily high quality and/or reliability or a malfunction or failure of which may cause loss of human life or bodily injury ("Unintended Usage"). Unintended Usage include atomic energy control instruments, airplane or spaceship instruments, transportation instruments, traffic signal instruments, combustion control instruments, medical instruments, all types of safety devices, etc.. Unintended Usage of TOSHIBA products listed in this document shall be made at the customer's own risk.
- The products described in this document are subject to the foreign exchange and foreign trade laws.
- The information contained herein is presented only as a guide for the applications of our products. No responsibility is assumed by TOSHIBA CORPORATION for any infringements of intellectual property or other rights of the third parties which may result from its use. No license is granted by implication or otherwise under any intellectual property or other rights of TOSHIBA CORPORATION or others.
- The information contained herein is subject to change without notice.