

TOSHIBA BIPOLAR LINEAR INTEGRATED CIRCUIT SILICON MONOLITHIC

# TA2030FN

## TV/FM SYSTEM F/E (1.5V USE)

The TA2030FN is a TV/FM SYSTEM FRONT END IC, which is developed for headphone radio in 1.5V use. It is built in FM F/E and TV F/E (Japanese VHF band).

### FEATURES

- Built-in FM F/E and TV F/E  
FM mode : 75~109MHz  
TV mode : 175~225MHz
- Suitable for combination with Digital Tuning System.
- Built-in power switch
- Built-in FM/TV switch
- Built-in IF amplifier
- Built-in OSC buffer circuit
- Improved Inter-Modulation characteristics by Double Balanced Type Mixer circuit.
- Supply current ( $V_{CC} = 1.2V$ ,  $T_a = 25^\circ C$ )  
FM mode :  $I_{CC} = 4.4mA$  (Typ.)  
TV mode :  $I_{CC} = 6.3mA$  (Typ.)
- Operating supply voltage range ( $T_a = 25^\circ C$ )  
 $V_{CC} (opr) = 0.95 \sim 4V$

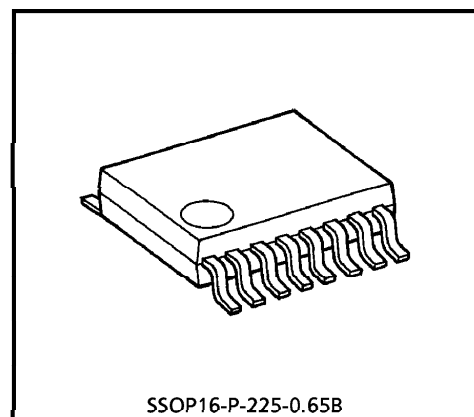

SSOP16-P-225-0.65B

Weight : 0.09g (Typ.)

980508EBA2

- TOSHIBA is continually working to improve the quality and the reliability of its products. Nevertheless, semiconductor devices in general can malfunction or fail due to their inherent electrical sensitivity and vulnerability to physical stress. It is the responsibility of the buyer, when utilizing TOSHIBA products, to observe standards of safety, and to avoid situations in which a malfunction or failure of a TOSHIBA product could cause loss of human life, bodily injury or damage to property. In developing your designs, please ensure that TOSHIBA products are used within specified operating ranges as set forth in the most recent products specifications. Also, please keep in mind the precautions and conditions set forth in the TOSHIBA Semiconductor Reliability Handbook.
- The products described in this document are subject to foreign exchange and foreign trade laws.
- The information contained herein is presented only as a guide for the applications of our products. No responsibility is assumed by TOSHIBA CORPORATION for any infringements of intellectual property or other rights of the third parties which may result from its use. No license is granted by implication or otherwise under any intellectual property or other rights of TOSHIBA CORPORATION or others.
- The information contained herein is subject to change without notice.

**BLOCK DIAGRAM**

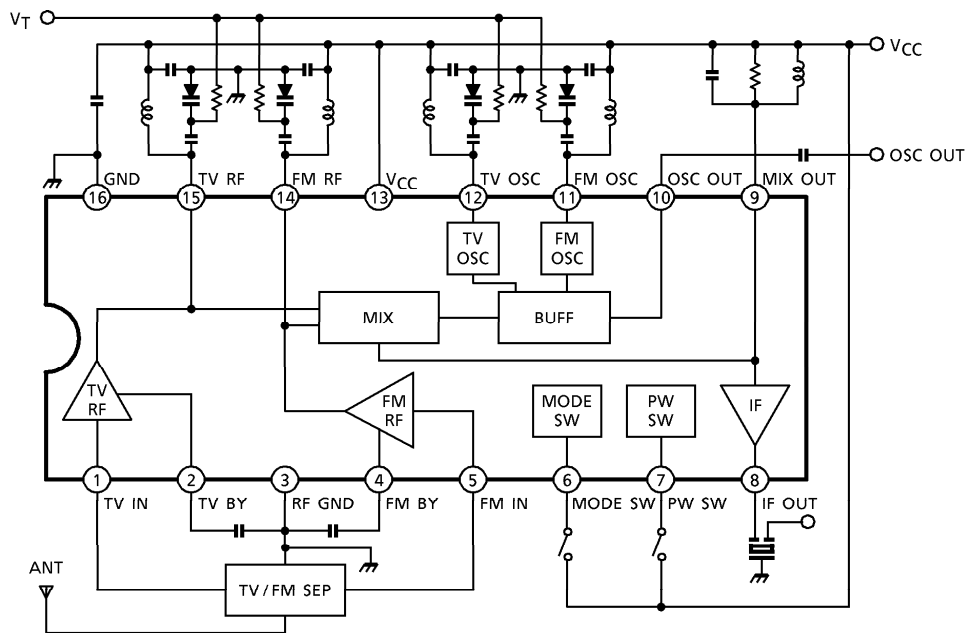

**TERMINAL EXPLANATION**

Terminal voltage : Typical terminal voltage at no signal with test circuit. ( $V_{CC} = 1.2V$ ,  $T_a = 25^\circ C$ )

TERMI- NAL No.	TERMINAL NAME	FUNCTION	INTERNAL CIRCUIT	TERMINAL VOLTAGE (V)	
				FM	TV
1	TV IN	Input of TV RF signal (Common-base type)		—	0.1
2	TV BY	By-pass terminal of TV RF and MIX (Radiation is lightened by connected capacitor.)		—	0.7
15	TV RF	TV RF tuning circuit is connected.		1.2	1.2
3	RF GND	—	—	0	0
4	FM BY	By-pass terminal of FM RF and MIX (Radiation is lightened by connected capacitor.)		0.7	—
5	FM IN	Input of FM RF signal (Common-base type)		0.1	—
14	FM RF	FM RF tuning circuit is connected.		1.2	1.2
6	MODE SW	Mode switch ( $V_{CC}$ : TV Mode Open / GND : FM Mode)		0	1.2
7	PW SW	Power switch ( $V_{CC}$ : Power on Open / GND : Power off)		1.2	1.2
8	IF OUT	Output of TV / FM IF signal. Output impedance 330Ω (Typ.)		1.1	1.1
9	MIX OUT	MIX coil is connected.		1.2	1.2

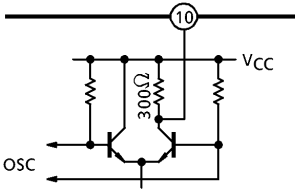
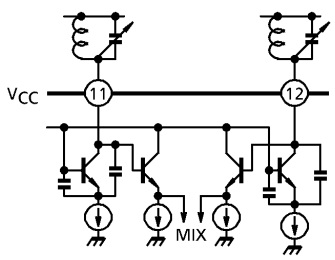
TERMI- NAL No.	TERMINAL NAME	FUNCTION	INTERNAL CIRCUIT	TERMINAL VOLTAGE (V)	
				FM	TV
10	OSC OUT	Output of OSC buffer circuit.		1.1	1.1
11	FM OSC	FM OSC tank circuit is connected. (Colpitts type oscillator)		1.2	1.2
12	TV OSC	TV OSC tank circuit is connected. (Colpitts type oscillator)		1.2	1.2
13	VCC	VCC		1.2	1.2
16	GND	GND (Except RF Part)		0	0

**APPLICATION NOTE**

1. PW SW

It is necessary to connect an external pull-down resistor with the terminal PW SW (pin⑦), in case that this IC is turned on due to external noise etc.

2. MODE SW

It is necessary to connect an external pull-down resistor with the terminal MODE SW (pin⑥), in case that this IC doesn't operate normally due to external noise etc.

3. RF GND

This IC has two GND terminals (pin③ : RF GND, pin⑯ : GND). External parts shown in below should be connected with RF GND (pin③), and other parts should be connected with GND (pin⑯).

- By-pass capacitor at pin⑭ (FM RF) and pin⑮ (TV RF)
- By-pass capacitor at pin④ (FM BY) and pin② (TV BY)

The pattern diagram of capacitor connected with pin② and pin④ should be shortly, because RF circuit and MIX circuit operate on the voltage of pin② or pin④.

**MAXIMUM RATINGS (Ta = 25°C)**

CHARACTERISTIC	SYMBOL	RATING	UNIT
Supply Voltage	V <sub>CC</sub>	4.5	V
Power Dissipation (Note)	P <sub>D</sub>	400	mW
Operating Temperature	T <sub>opr</sub>	-25~75	°C
Storage Temperature	T <sub>stg</sub>	-55~150	

(Note) Derated above Ta = 25°C in the proportion of 3.2mW/°C.

**ELECTRICAL CHARACTERISTICS**

Unless otherwise specified, V<sub>CC</sub> = 1.2V, Ta = 25°C, f<sub>FM</sub> = 92MHz, f<sub>TV</sub> = 200MHz  
 Δf = ±22.5kHz, f<sub>m</sub> = 1kHz, SW<sub>2</sub> : b

CHARACTERISTIC	SYMBOL	TEST CIR-CUIT	SW <sub>1</sub>	TEST CONDITION	MIN.	TYP.	MAX.	UNIT	
Supply Current	I <sub>CC1</sub>	1	a	V <sub>in</sub> < -20dBμV EMF	IC OFF, SW <sub>2</sub> : a	—	0.1	5	μA
	I <sub>CC2</sub>				FM mode	—	4.4	6.6	mA
	I <sub>CC3</sub>				TV mode	—	6.3	9.5	
FM	Conversion Gain	G <sub>C1</sub>	a	V <sub>in</sub> = 65dBμV EMF f <sub>osc</sub> = 65MHz	29	33	—	dB	
	Local Oscillator Voltage	V <sub>osc1</sub>			—	360	—		mV <sub>rms</sub>
	OSC Buffer Output Voltage	V <sub>BUF1</sub>			—	50	—		
	Local Oscillator Stop Voltage	V <sub>STP1</sub>			—	0.89	0.95	V	
TV	Conversion Gain	G <sub>C2</sub>	b	V <sub>in</sub> = 65dBμV EMF f <sub>osc</sub> = 165MHz	25	29	—	dB	
	Local Oscillator Voltage	V <sub>osc2</sub>			—	180	—		mV <sub>rms</sub>
	OSC Buffer Output Voltage	V <sub>BUF2</sub>			—	22	—		
	Local Oscillator Stop Voltage	V <sub>STP2</sub>			—	0.86	0.95	V	
Power On Current	I <sub>7</sub>	1	a	V <sub>CC</sub> = 0.95V, V <sub>2</sub> ≤ 0.2V SW <sub>2</sub> : d V <sub>4</sub> ≥ 0.4V	5	—	—	μA	
Power Off Voltage	V <sub>7</sub>		a	V <sub>CC</sub> = 0.95V, V <sub>2</sub> ≤ 0.2V SW <sub>2</sub> : c V <sub>4</sub> ≤ 0.2V	0	—	0.3	V	
TV Mode On Current	I <sub>6</sub>		d	V <sub>CC</sub> = 0.95V, V <sub>2</sub> ≥ 0.4V V <sub>4</sub> ≤ 0.2V	5	—	—	μA	
FM Mode On Voltage	V <sub>6</sub>		c	V <sub>CC</sub> = 0.95V, V <sub>2</sub> ≤ 0.2V V <sub>4</sub> ≥ 0.4V	0	—	0.3	V	



TEST CIRCUIT 3

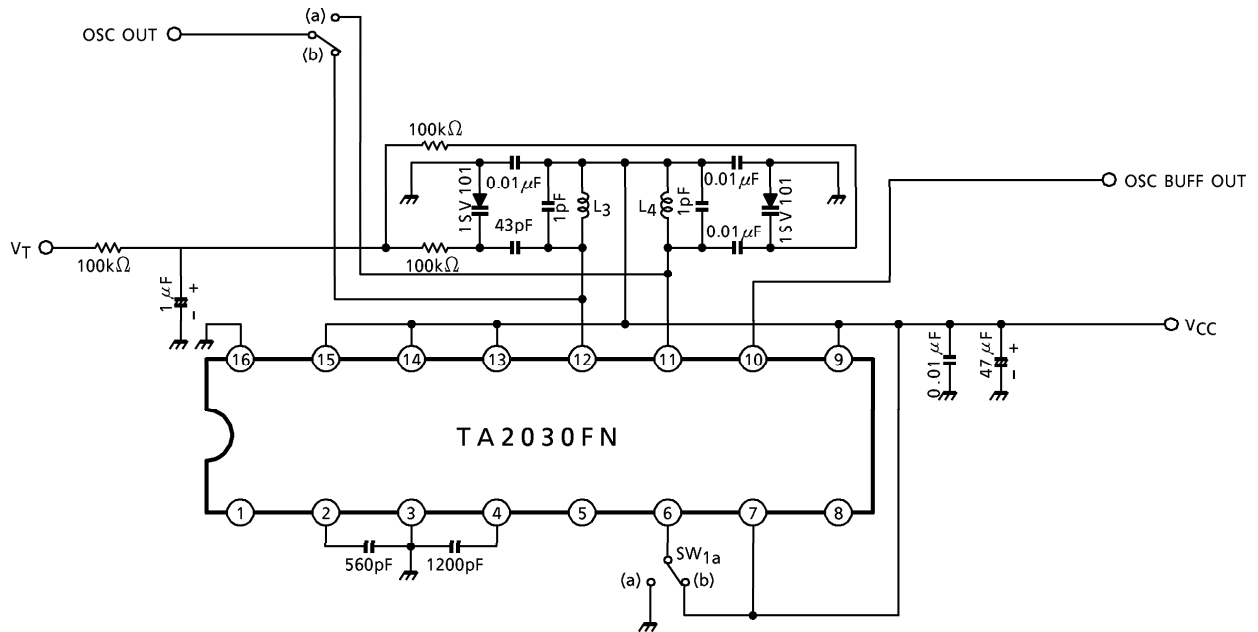

COIL DATA (Test circuit)

COIL No.	TEST FREQ.	C <sub>0</sub> (pF)	Q <sub>0</sub>	TURNS		WIRE (mm φ)	REFERENCE
				1-3	1-4		
L <sub>1</sub> TV RF	100MHz	—	55	1 1/4	—	0.5UEW	Ⓢ 0258-250
L <sub>2</sub> FM RF	100MHz	—	90	—	3 1/2	0.5UEW	Ⓢ 0258-238
L <sub>3</sub> TV OSC	100MHz	—	55	1 1/4	—	0.5UEW	Ⓢ 0258-250
L <sub>4</sub> FM OSC	100MHz	—	90	—	3 1/2	0.5UEW	Ⓢ 0258-238
T FM IFT	10.7MHz	82	45	18	—	0.09UEW	Ⓢ 4162-083A

Ⓢ : SUMIDA ELECTRIC CO., LTD.

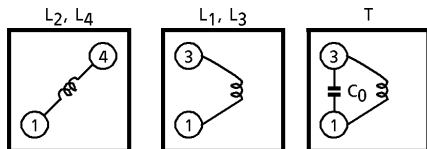

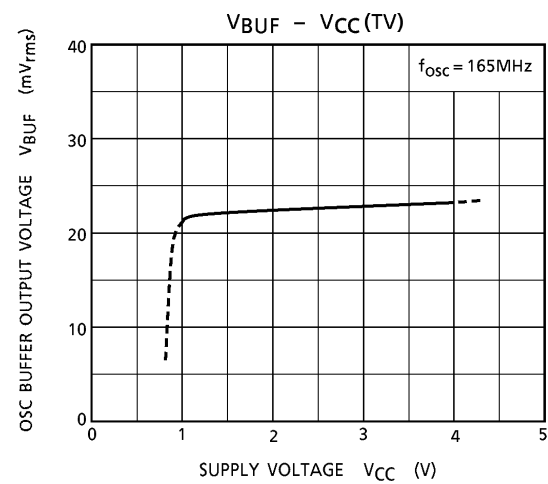
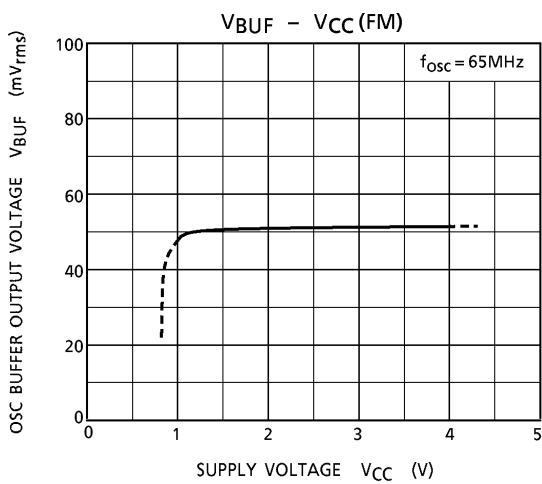
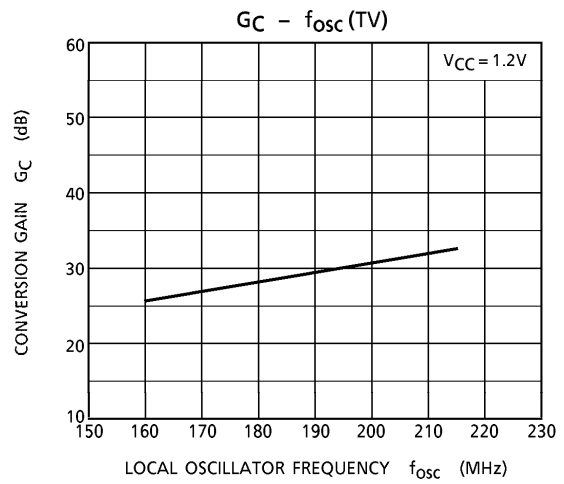
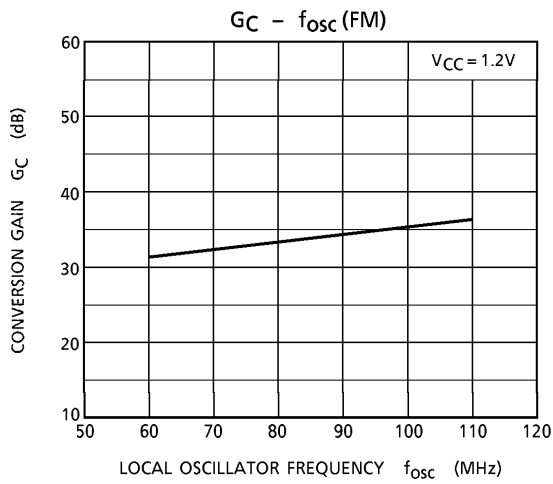
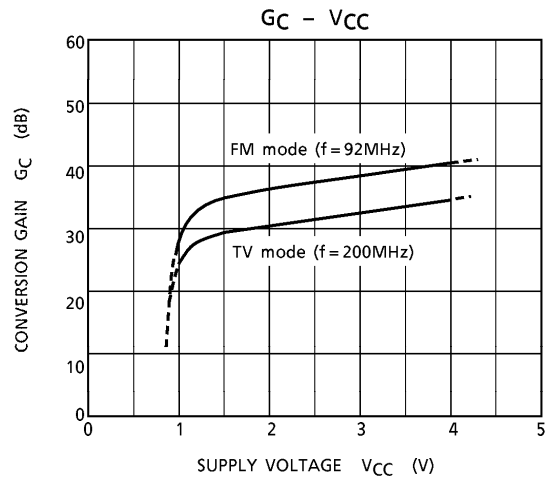
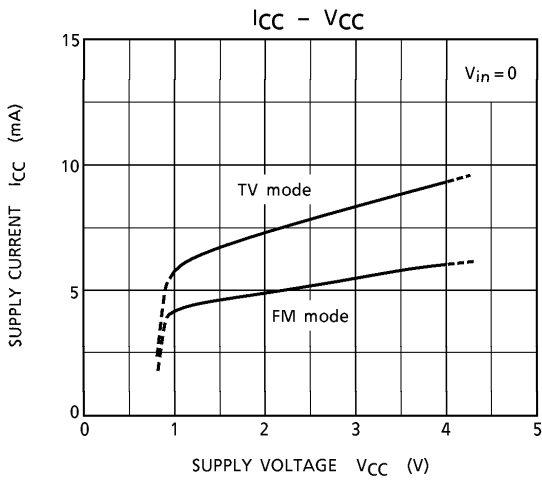



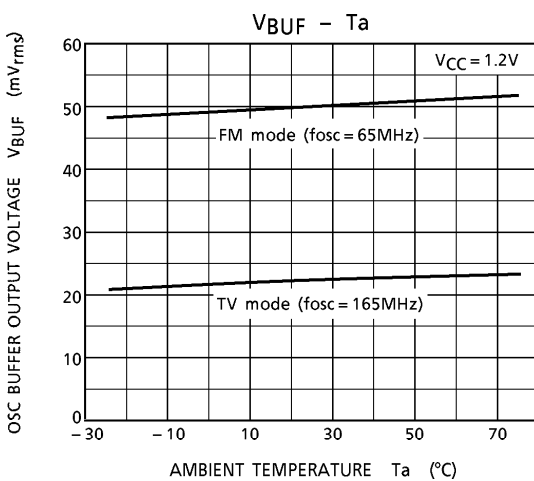
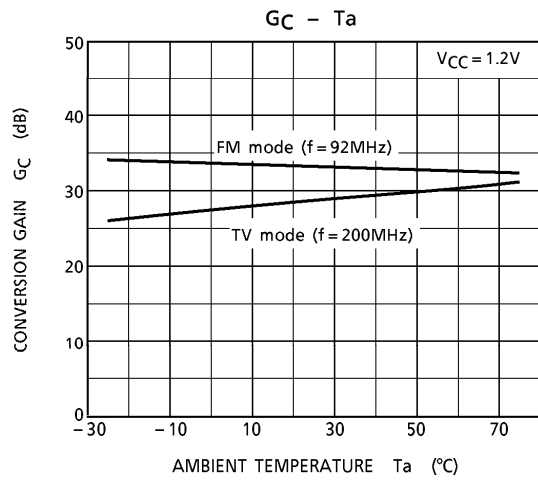
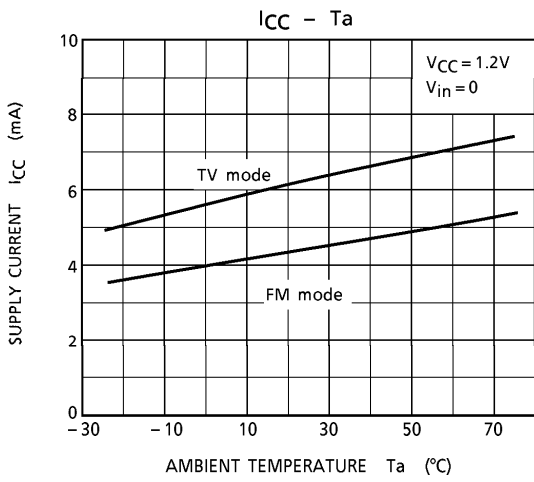
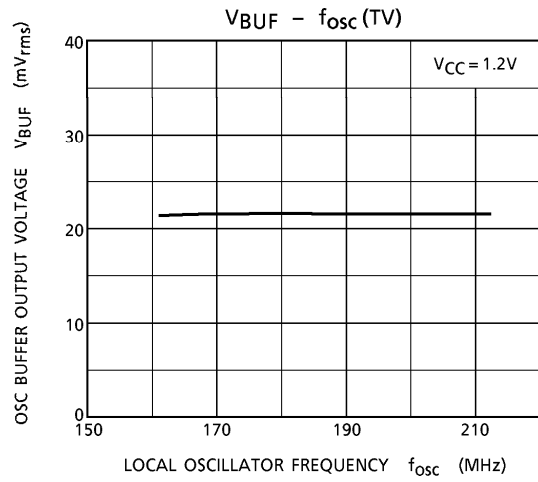
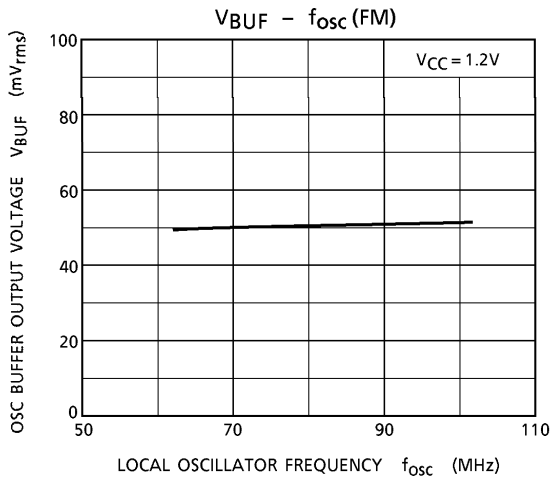

**OUTLINE DRAWING**  
SSOP16-P-225-0.65B

Unit : mm

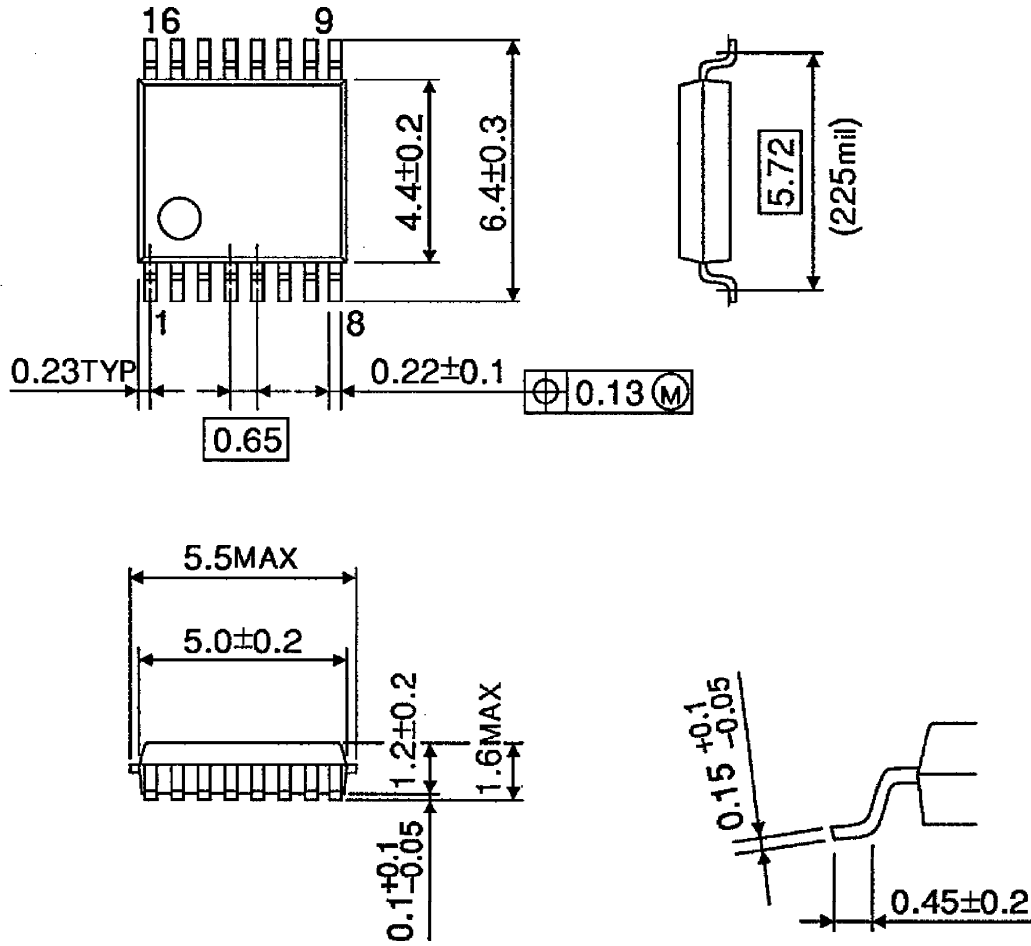

Weight : 0.09g (Typ.)