

MASK - PROGRAMMABLE SPEECH CIRCUITS

ADVANCE DATA

Key Options

- MICROPHONE TYPES SUCH AS ELECTRO-DYNAMIC/MAGNETIC, ELECTRET OR CERAMIC
- POWER SUPPLY FOR EXTERNAL CIRCUITRY
- AGC CIRCUIT
- LINE REGULATION OF TRANSMIT/RECEIVE GAIN FOR CERTAIN TELEPHONE STATION POWER SUPPLIES
- EXTRA POWER SUPPLY INPUTS FOR OUTPUT AMPLIFIER TO BE USED IN HAND-FREE TELEPHONES
- SPECIAL IMPEDANCE/GAIN REQUIREMENTS
- MUTE OR TRANSMIT/RECEIVE AMPLIFIERS WITH OR WITHOUT CONFIRMATION TONE
- ACOUSTIC SHOCK ARRESTORS
- SIDETONE CANCELLATION CIRCUITRY

Pin Options

- MUTE/NO MUTE FUNCTION
- REGULATION OF SIDETONE WITH LINE LENGTH
- CUT OFF OF ALL LINE REGULATION

External Components (step by step)

- DC CHARACTERISTICS
- IMPEDANCE
- TRANSMIT GAIN
- TRANSMIT LINEARITY
- RECEIVE GAIN
- RECEIVE LINEARITY
- SIDETONE
- LOW VOLTAGE OPERATION

DESCRIPTION

PBL3726 is a family of mask-programmable speech circuits intended for various telephone applications. The flexibility of these circuits allows use of versions of PBL3726 in all telecom markets, whether it be in an ordinary telephone, a hands-free multi-function phone or even as a trunk interface. The versatility is based on three levels :

- Mask options for special requirements
- Pin options on certain functions
- Step-by-step design possibility on the basic telephone functions making it possible to cut down design time to a minimum. This is done by changing the values of a small number of external components.

ABSOLUTE MAXIMUM RATINGS

Maximum Ratings over Operating Free-air Temperature Range (unless otherwise stated)

Symbol	Parameter	Test Conditions	Unit
V _{DC}	Line Voltage, t _p = 2 s	22	V
I _{DC}	Continuous Operating Line Current (*)	100	mA
T _j	Junction Temperature	+ 150	°C
T _{amb}	Operating Ambient Temperature	- 40 to + 70	°C
T _{stg}	Storage Temperature	- 55 to + 150	°C

(*) Max current increases linearly up to 130mA with max operating temperature lowered to + 55°C.

Figure 1 : Block Diagram and Typical Application.

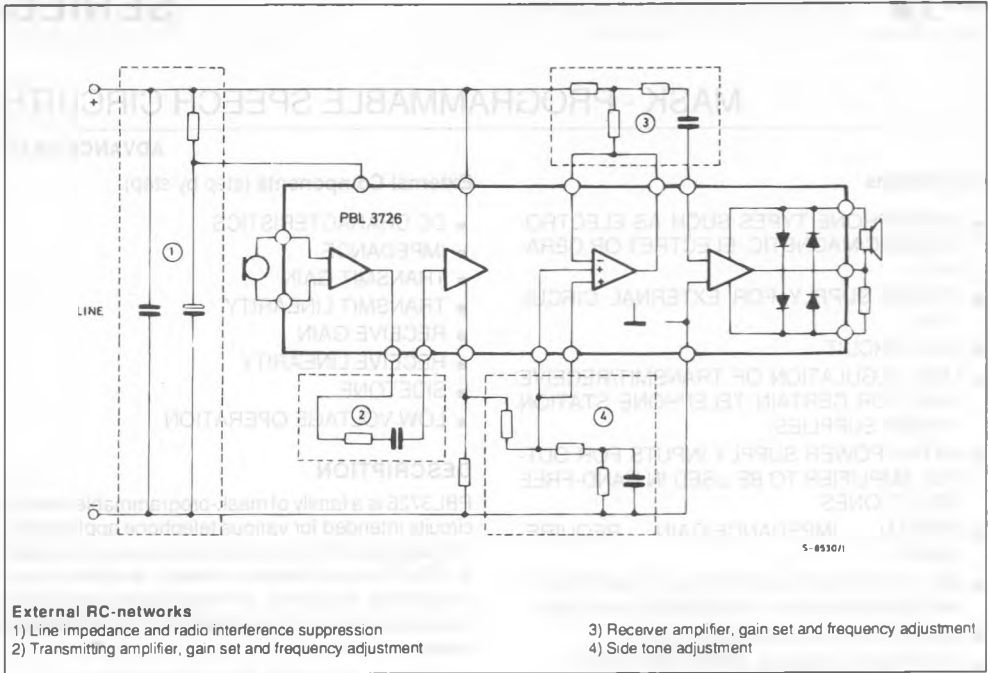

For recommended operating conditions see specific data sheets for different versions of PBL3726

FUNCTIONAL DESCRIPTION

The gains of the transmitting and receiving amplifiers are continuously and equally changed with the line length. The gain regulation can be cut off externally, and the gain will then be the maximum gain normally used at long lines.

The outputs of the transmitting and receiving amplifiers have internal limitations as to the output amplitudes.

The circuit includes a temperature independent voltage reference used for regulating the DC line current and for regulating the transmitting and receiving gain. The DC voltage quickly settles to its final value with a minimum of overshoot.

The circuit needs few external components. In a normal practical case there are only 5 external capacitors, one of which is an electrolytic/tantalum filter capacitor. The other capacitors are needed for radio interference suppression, to function in the sidetone balancing network, and to provide low frequency cut-off in each of the transmitting and receiving amplifiers.

The circuit has an excellent return loss characteristic against both purely resistive lines such as 600 Ω and against complex networks such as 900 Ω in parallel with 30 nF.

The microphone input is balanced to provide a good CMRR.

It is possible to add a push-button controlled cut-off of the transmitting amplifier of the circuit without disturbing any of the other circuit functions.

A mute input is included to :

- 1) Cut off the transmitting amplifier (F₁)
- 2) Reduce gain in the receiving amplifier
- 3) Reduce current consumption to lower power loss

The DC regulation works independently of the mute function and is not influenced by the mute signal. External mute-control of the circuit from a DTMF generator is then possible.

The receiver amplifier is equipped with a high impedance input stage, allowing a less expensive RC network on the input.

Only resistive elements are used to set the receiving gain.

A push-pull power stage in the receiving amplifier provides a high output swing.

The sidetone balance can be set by an RC network without influencing other parameters. An inexpensive solution requires only one capacitor whereas more capacitors may provide better performance. The sidetone can be regulated with respect to line length.

A separate amplifier stage (F_3) can be used in several different ways, for instance.

- 1) Separating the sidetone balance network
- 2) Compensating sidetone level for line length
- 3) Providing an extra 20dB gain for volume control of the receiving amplifier, etc.

This amplifier has many uses. In the following part only two examples of its use are given.

Figure 2.

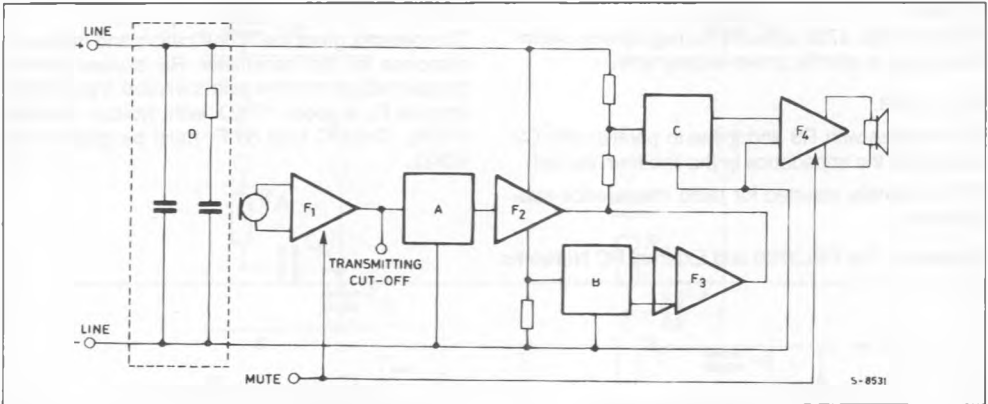

A, B, C and D are RC links with the following functions :

A : To set the gain and frequency response for transmitting

B : To set the sidetone level (regulation with line length is possible)

C : To set the gain and frequency response for receiving

D : For radio interference suppression and to give the correct return loss behaviour

Figure 3.

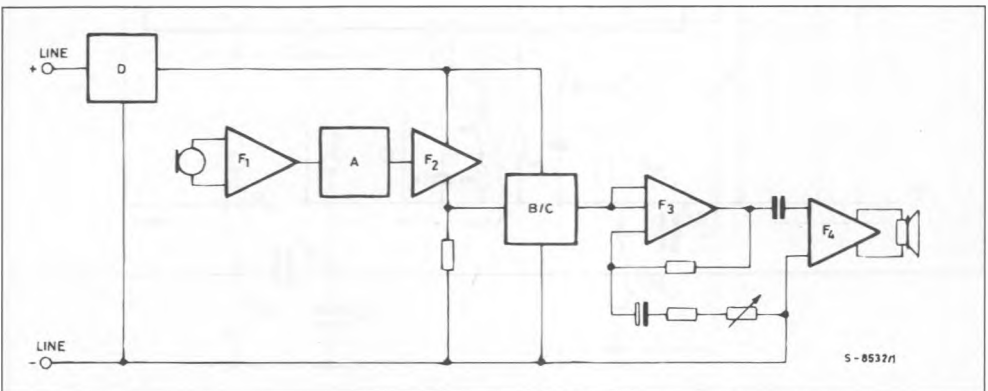

In this case an extra 20 dB amplification is added to the receiving part. A potentiometer provides the

possibility of adjusting the gain to the required level.

BASIC EXTERNAL COMPONENTS

R1, R2.

These resistors set the starting point for the gain and sidetone regulation.

Input impedance on the regulator is about $52K\Omega \pm 2\%$. Only universal versions of PBL 3726 like PBL3726/6, 3726/9 etc. are equipped with this option. In the data sheets for these versions there is a table showing the R1, R2 values for different central office power supplies. The regulation can also be cut off by leaving R1 open and shorting R2 to-LINE voltage.

For other PBL 3726 versions the regulation is set internally for a specific power supply type.

C1, C2, R3.

C1 in series with R3 and these in parallel with C2 determine the impedance to the line from the set.

C2 is normally inserted for radio interference suppression.

The network is optimized with regard to the return loss.

The R3, C1 combination forms a low-pass filter in the DC-feedback loop of the transmitting amplifier. If the R3 C1 time constant is too low there may be distortion at low frequencies.

If R3 is changed this will change the DC characteristics too which is set by the voltage at V_{DD}. The input current at V_{DD} is about 1 mA.

R4, R5, C3, C4.

The network gives the amplification and frequency response for the transmitter. R5 is used when a greater reduction of the gain is wanted. Input impedance at F₂ is about $17K\Omega$ with typical variation $\pm 20\%$. The DC load on F₁ must be greater than $40K\Omega$.

Figure 4 : The PBL3726 and External RC Networks.

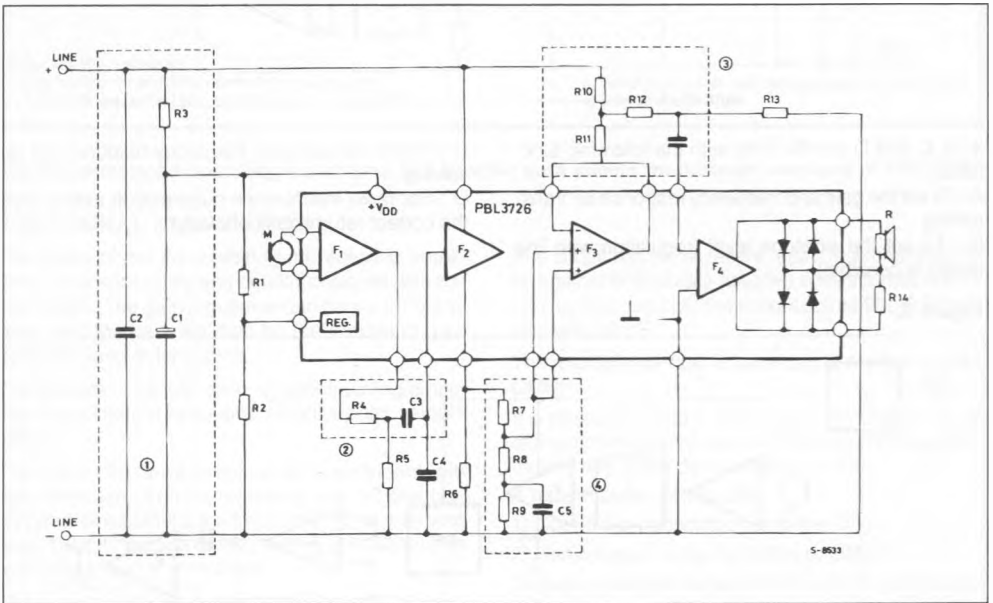
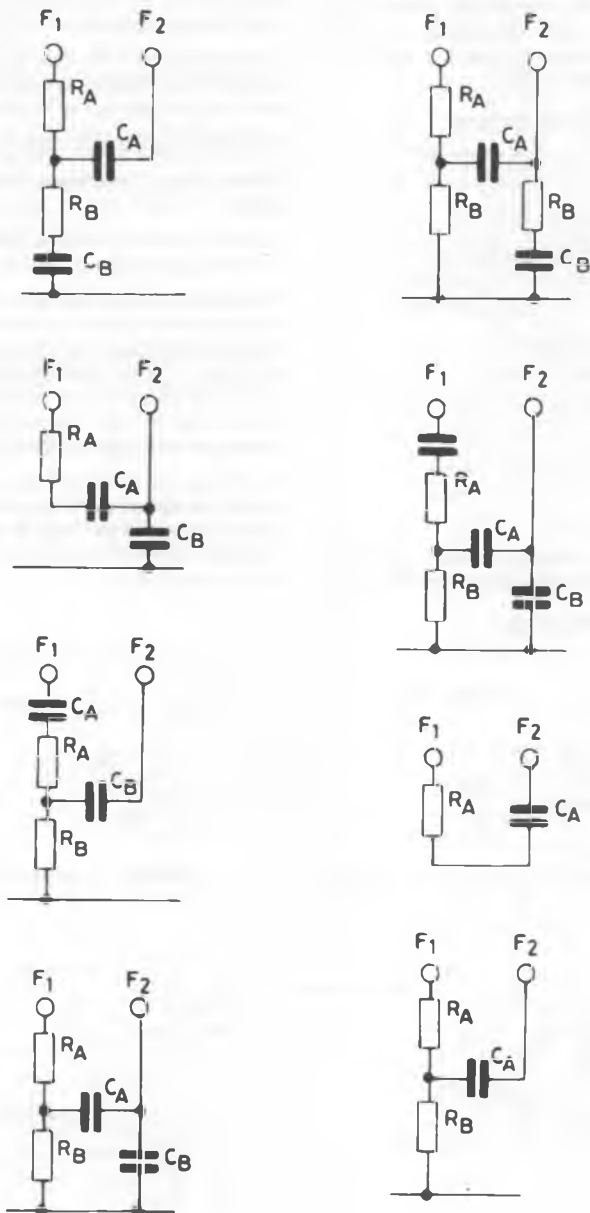

Figure 5 : Typical Filters.



S-8534

R6.

Sets the DC Characteristics and dissipates some of the supplied power. The resistor also affects, the transmitter gain, the output amplitude from the transmitter, the gain regulation and the sidetone. Common values are 68Ω to 82Ω .

Figure 6 : Typical DC Characteristics.

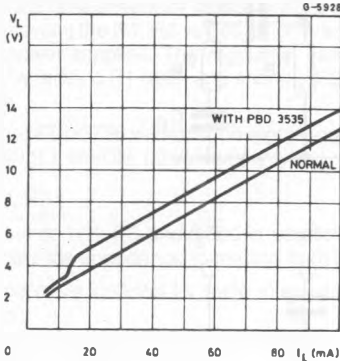

R7, R8, R9, R10, R11, C5.

This network sets the sidetone balance. The network in the application is one of many possibilities.

Figure 7 : Sidetone Network.

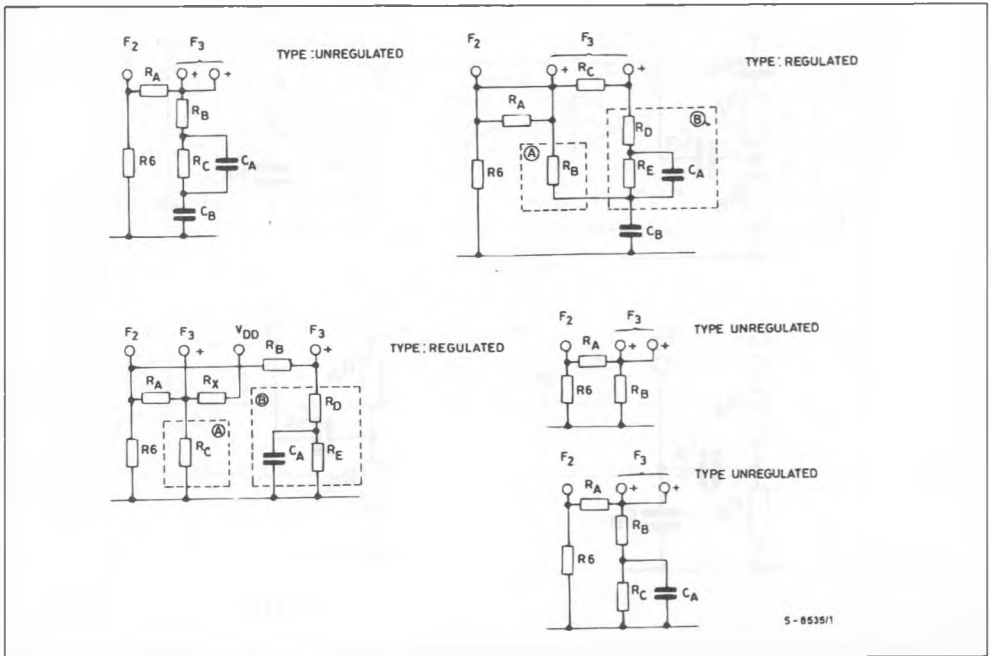

R10 an R11 together balance the signals that exit two different ways from the transmitter output stage, one from pin 1 and the other from pin 2. The balance network consists of R8, R9 and C5.

Examples given in the data sheets for different versions of PBL3726 are not optimized to any specified line : they are given only to show the principle.

Amplifier F₃ has a high input impedance.

Shown in fig. 7 are some different sidetone networks.

Construction of a sidetone network with regulation according to the above can be done as follows :

The balance impedance A is optimized at a short line where the regulation starts. The balance impedance B is optimized at a long line where the regulation stops. The circuit generates a continuous change between the two balance impedances. R_x insures that no DC voltage shall be between F₃'s double positive inputs at the change.

By breaking up between the negative input and output of F₃ it can be used as an amplifier with amplification greater than unit. In fig. 8 two balance networks without F₃ are shown. F₃ can then be used in other applications.

In fig. 9 a circuit is shown, where F_3 is used as an amplifier with an extra 20dB gain at receiving and with a volume control.

R12, R13, C6 (R10, R11).

The network gives the gain and frequency response for the receiver.

R13 is used when a greater reduction of the gain is wanted. Input impedance F_4 is about $35K\Omega$ with typical variation $\pm 20\%$. For different possibilities for the design of the network, see the network for the transmitter (R4, R5, C3) in fig. 5.

R14.

Generates the output impedance to the magnetic earphone.

If a dynamic earphone is used it should be placed between outer connections. The middle connection is then not used.

This will give about a double output (for the same output current).

Rectifier. Rectifier bridge and over-voltage protector. The zener voltage at fig. 10 should be as low as possible. Common values are between 12V and 16V.

Figure 8 : Sidetone Network without F_3 .

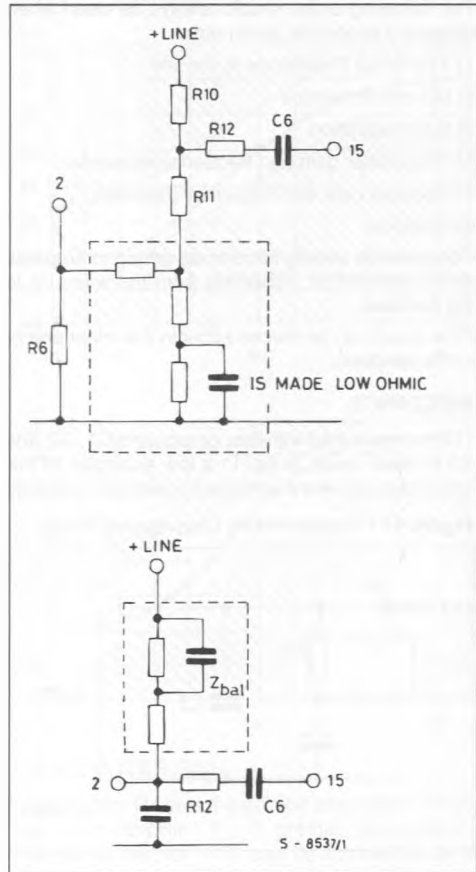

Figure 9 : 20dB Extra Amplifier (cannot be used in all version).

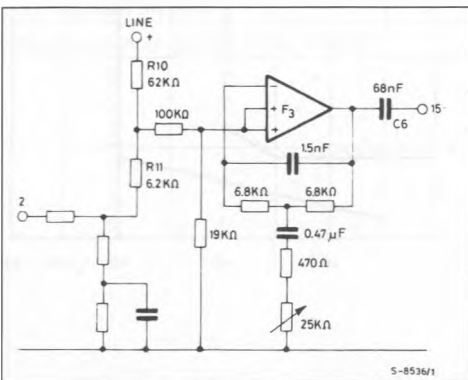
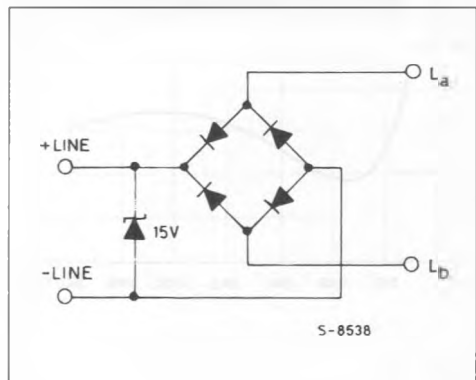

Figure 10 : Rectifier Bridge and Overvoltage Protection.



DESIGN RULES

The following order should always be used when designing telephone parameters.

- 1) The circuit impedance to the line
- 2) DC characteristics
- 3) Gain regulation
- 4) Transmitter gain and frequency response
- 5) Receiver gain and frequency response
- 6) Sidetone

Components usually have to be added to suppress radio interference, especially from the wires up to the handset.

(The circuit can be placed either in the telephone or in the handset).

IMPEDANCE.

This is determined with the components C1, C2, and R3 in most cases. In fig. 11 a few examples of this are shown. If a more complex impedance is desired

Figure 11 : Typical Return Loss Against 600Ω.

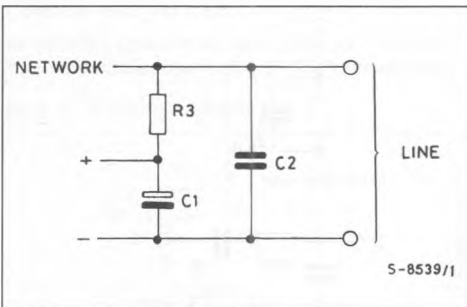

as in the example for British Telecom (fig. 12), this can also be achieved by copying the mathematical model of the desired impedance.

Examples of line impedance matching :

Impedance	R3	C1	C2
600 Ω	600 Ω	47 μF	15 nF
900 Ω, 30 nF	900 Ω	47 μF	15 nF
1.2 kΩ, 60 nF	1.2 kΩ	47 μF	47 nF

Figure 12 : Example of complex Impedance Matching.

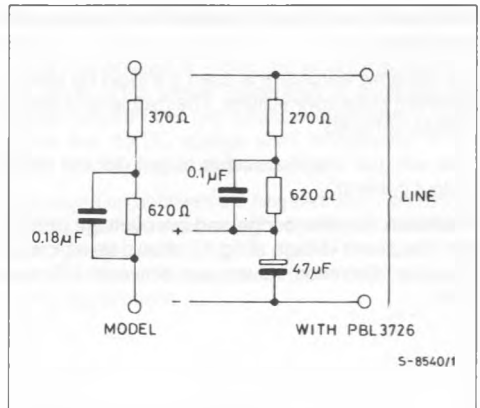

DC CHARACTERISTICS.

The slope of the DC characteristics is set by the resistor R6 (fig. 13). The lower value of R6, the flatter the slope. With the steeper slope the minimum DC

Figure 13 : Typical DC Characteristics.

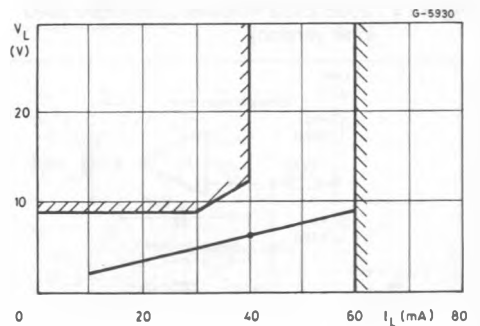
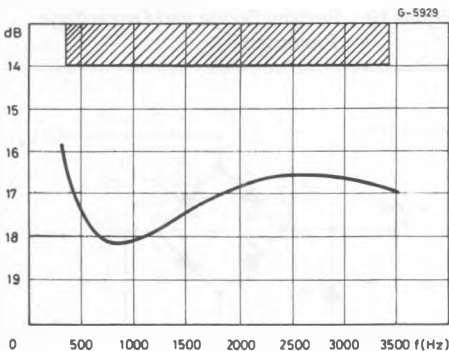

voltage also will go down. It is not recommended, though, to set the PBL3726 to DC voltages below 2.5V. If in some circumstances the DC characteristics of PBL3726 is too low, they can be raised by inserting an extra diode in series with the rectifier bridge as in fig. 14.

GAIN REGULATION.

When regulation with line length is used on send and receive gain, this can be set with the resistors R1 and R2. Note that not all versions are equipped with this function. By changing the values of these, the regulation attack can be set to fit any particular need.

Figure 14 : Rectifier Bridge with Extra Diode.

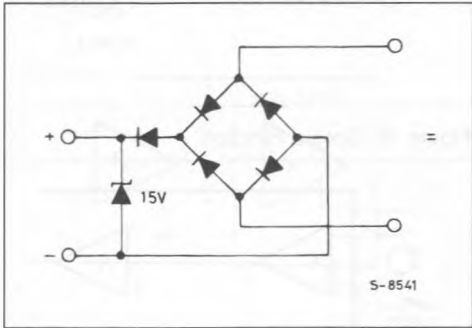

A table in the data sheets shows what values to use for some standard power supply systems. See example in fig. 15.

Figure 15 : Examples of Line-regulation Setting.

Line	R1	R2
50 V, 2 x 200 Ω	18 kΩ	47 kΩ
50 v, 2 x 400 Ω	9.1 kΩ	47 kΩ
50 V, 2 x 800 Ω	0	∞
Unregulated (all lines)	∞	0

Regulation input (pin 6 on PBL3726/6)

Figure 16 : Typical Gain Regulation with Line Length.

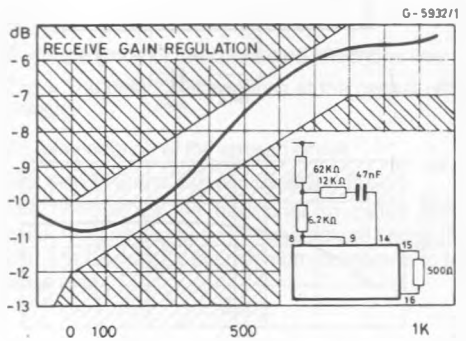
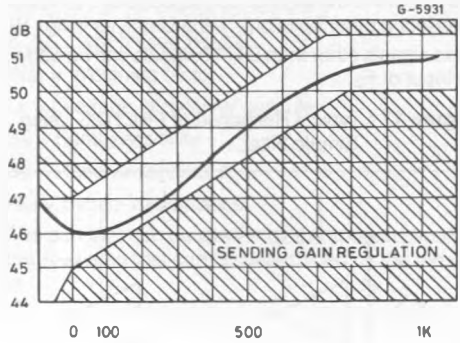

TRANSMITTER GAIN.

The resistor R4 sets the gain by attenuating the signal from amplifier F₁. If greater attenuation is needed a resistor (R5) can be connected to the minus line.

To get a frequency response appropriate for the microphone used a filter function as in fig. 5 can be used. These filters were previously described in this document.

The circuit can be provided with an unbalanced input as in fig. 18.

Cut off of the transmitter can be done at F_1 without interfering other functions of the circuit as in fig. 19.

Also signals other than DTMF signals can be added at input of F_2 .

Figure 17 : Typical Response of PBL3726 Using Simple Filter.

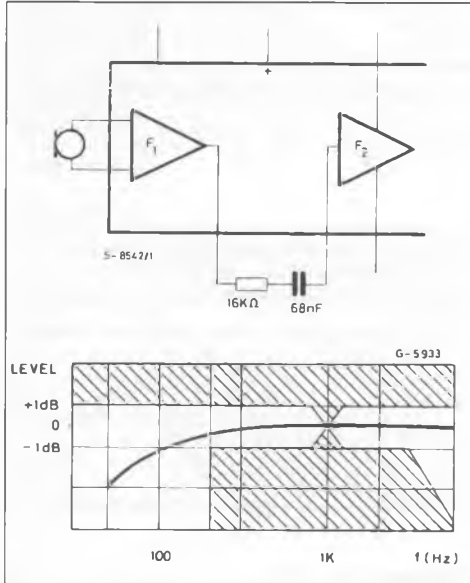

For the version originally developed for electrodynamic/magnetic microphones it is also possible to use electret microphones as shown in fig. 20.

Figure 20 : Alternative Microphones of Electromagnetic and Electrodynamic Types for PBL3726.

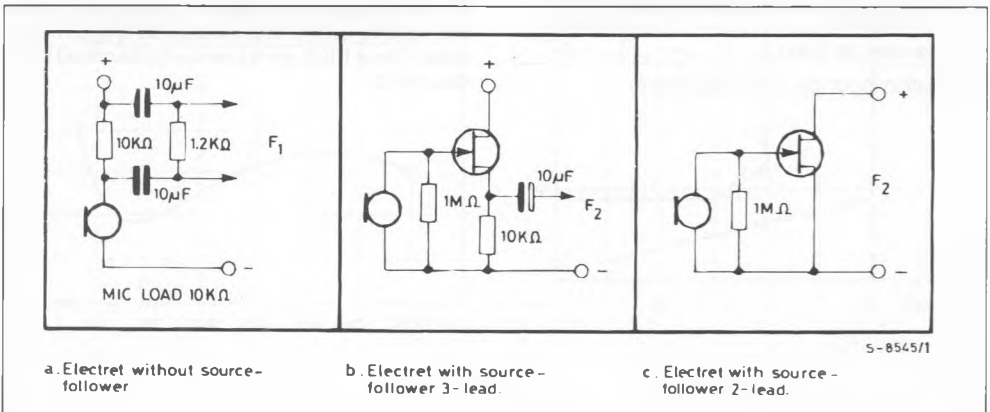

RECEIVER GAIN

In order to get the correct gain on the receive side, resistors R10 - R13 are used. Remember that R10 and R11 also set the rough ratio of the sidetone. R13 is used only in extreme circumstances, where a very

Figure 18 : Unbalanced Input.

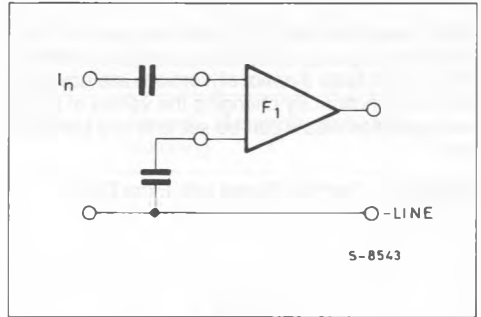
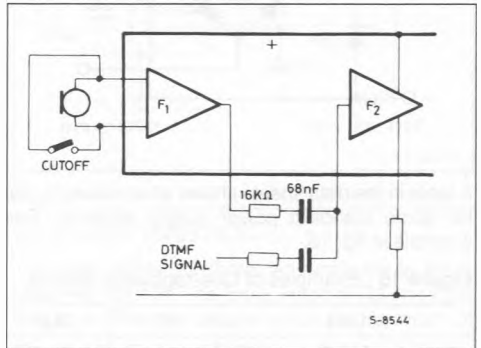

Figure 19 : Special Function.



high receive gain attenuation is needed. The frequency response can be altered with the same filters used for the send gain (see fig. 5). To get protection against acoustic shock the diodes provided on some versions after the output of F₄ can be used.

One or two diode pairs can be used. Should this not be enough a resistor can be connected after the diodes (in series). This should be done before the setting of the receive gain.

Figure 21 : Typical Receive Gain.

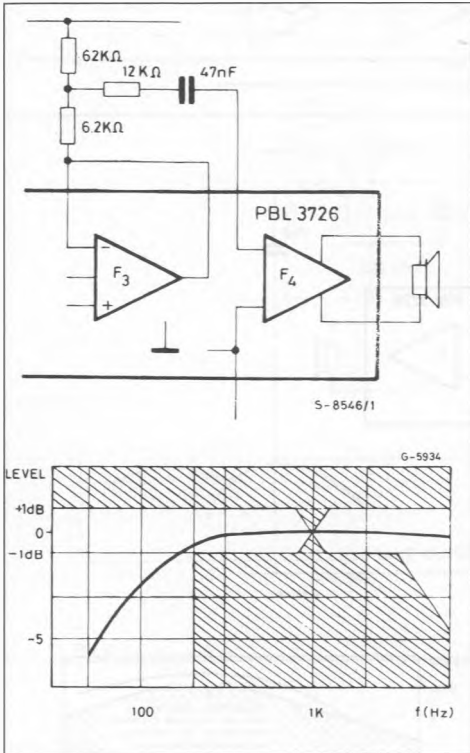

SIDETONE

$$STMR = -\frac{10}{m} \times 10 \log \left\{ 14 - \frac{m}{\sum_{i=1}^{10} 10} (W_{ST} + L_E S_S + S_R + A_{rst}) \right\}$$

The most difficult part of the design work is always to define the sidetone. This should always be done last when designing with PBL3726. The sidetone is the sound of your own voice fed back into the ear by the handset.

The subjective effect of this is best seen in the formula above for "Side Tone Masking Rating".

Summed at the frequencies f_i = 0.2, 0.25.....4KHz (see fig. 22)

W_{ST} = Weighing factor

L_E = Leakage at receiver capsule

S_S = Send sensitivity

S_R = Receive sensitivity

A_{rst} = Hybrid-loss balance

The part that can be altered by the speech circuit is the A_{rst} value that can be determined by the formula :

$$A_{rst} = 20 \log \left[\frac{Z_C + Z_{SO}}{2 Z_C} \times \frac{Z + Z_C}{Z - Z_{SO}} \right]$$

Where :

Z = Impedance of the connected telephone line

Z_{SO} = The balance impedance of the central office (PABX)

Z_C = Impedance of the speech circuit

The sum of Z and Z_{SO} can be called Z_{line}

The principle of the traditional so called active speech circuit has been the wheatstone bridge (fig. 23). The formula for the minimum sidetone is to balance until :

$$\frac{Z_2}{Z_1} = \frac{Z_{bal}}{Z_{line}}$$

Figure 22 : CCITT Factors.

f _i kHz	W _{ST} dB	L _E dB
0.2	86.4	8.4
0.25	81.9	4.9
0.315	78.5	1
0.4	78.2	- 0.7
0.5	72.8	- 2.2
0.63	67.6	- 2.6
0.8	58.4	- 3.2
1	49.7	- 2.3
1.25	48.0	- 1.2
1.6	48.7	- 0.1
2	50.7	3.6
2.5	49.8	7.4
3.15	48.4	6.7
4	49.2	8.8

The principle of PBL3726 is more complicated (even if calculation with the bridge in fig. 23 is possible). With the all-active bridge a method of cancelling the sidetone is a summing amplifier makes it possible to get not only one but two different sidetone optimums for different line lengths (see fig. 25). The function of the external components in fig. 7 have previously been described in this document. Fig. 26 shows an example of a sidetone network using the Wheatstone principle with PBL3726.

Figure 23 : Balance Bridge.

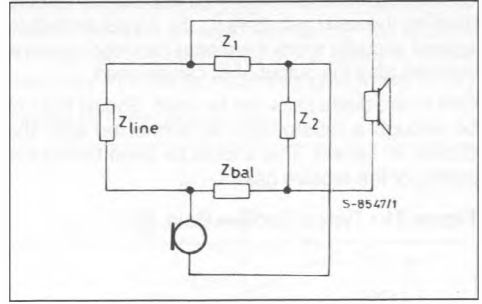

Figure 24 : Unregulated Sidetone Network.

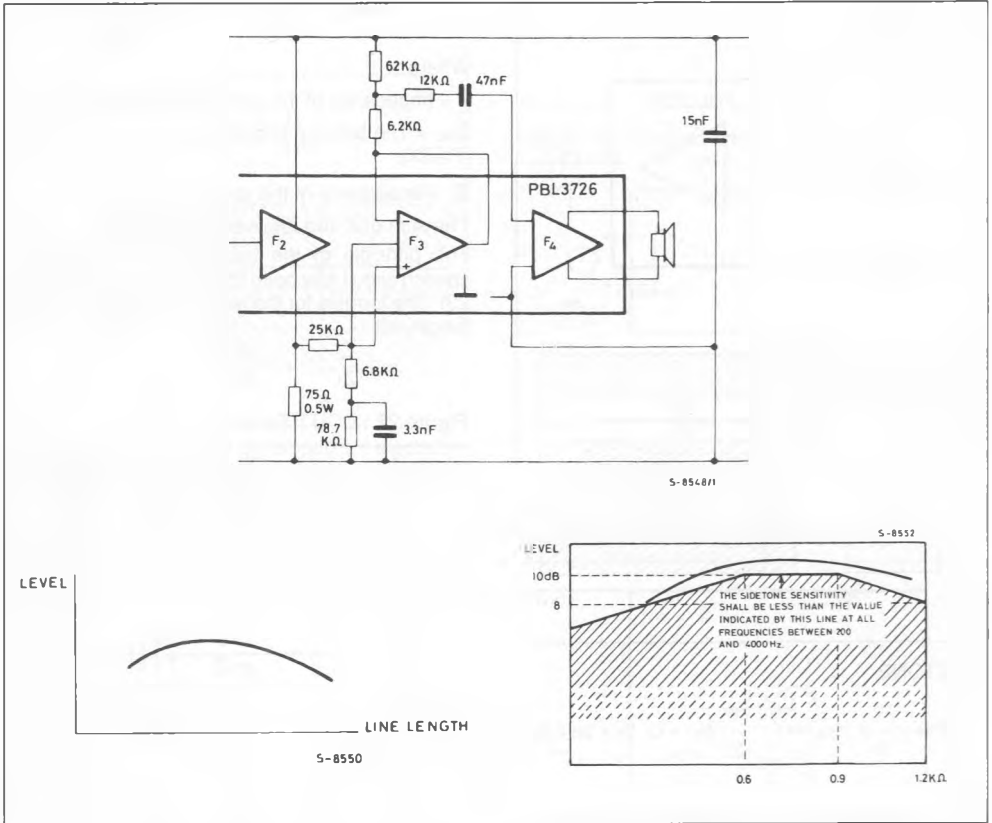
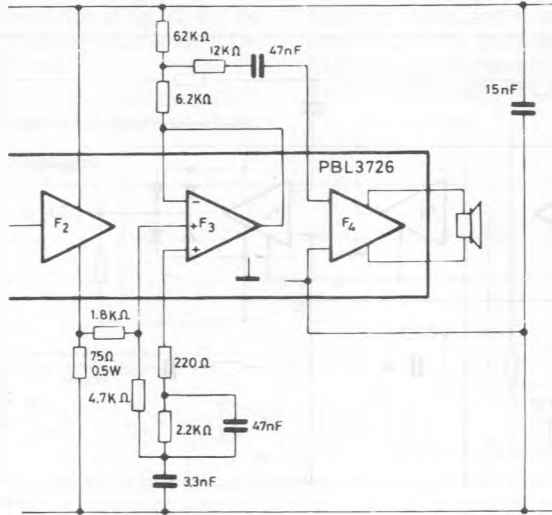
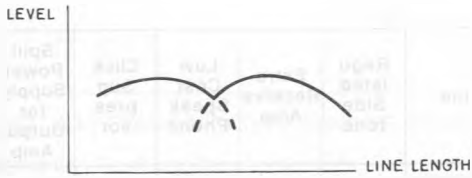

Figure 25 : Regulated Sidetone Network.



S-8549/1



S-8551

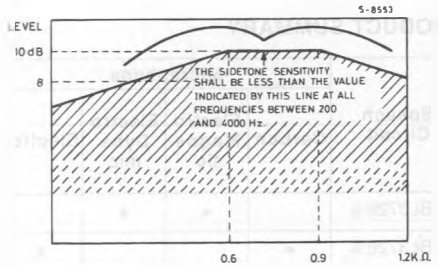

S-8553

Figure 26 : Wheatstone Type Sidetone Network.

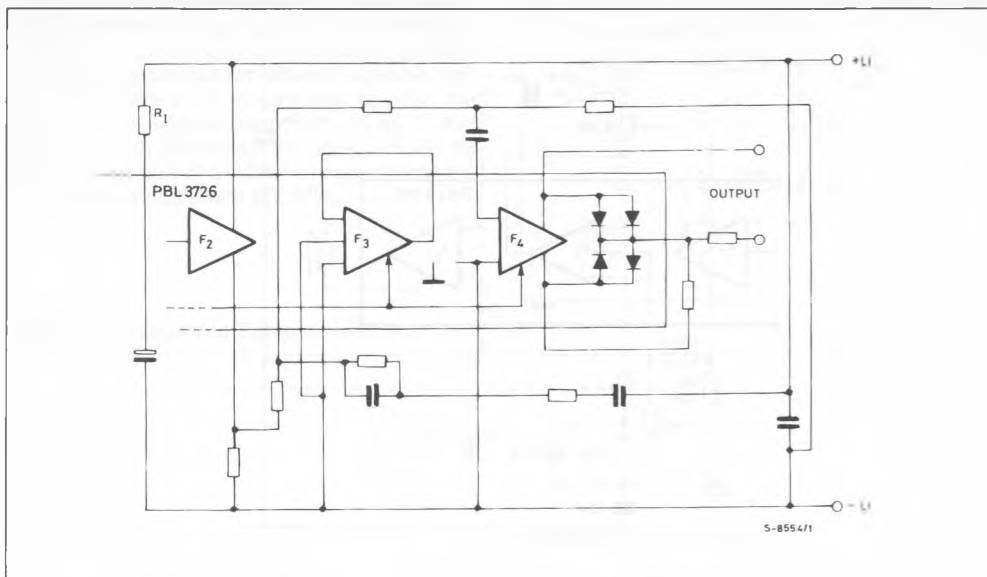

PRODUCT SUMMARY

Speech Circuit	Microphone				Line	Regulated Sidetone	Extra Receive Amp	Low Cost Speak Phone	Click Suppressor	Split Power Supply for Output Amp
	Carbon	Electro Magnetic	Electro Dynamic	Electret						
PBL3726/6		•	•		Adjustable	•	•	•	•	
PBL3726/8	•			•	36 V, 2 x 500 Ω 50 v, 2 x 800 Ω	•	•	•	•	
PBL3726/9	•			•	Adjustable	•	•	•	•	
PBL3726/11		•	•			•	•	•	•	
PBL3726/12		•	•		Adjustable	•	•	•	•	•

APPLICATIONS

To use PBL3726 in a hands-free telephone with a monitor function the schematics in fig. 27 can be used. The transformer should be rather efficient. Ordinary transistors can be used.

PBL3726 can also be used as trunk interface in modems, PABX, key systems etc where an analog

interface against the telephone line is needed. The balanced inputs and outputs make this possible together with the possibility of regulated sidetone. Examples of both one-way and two-way data/signal communication with PBL3726/6 are shown in fig. 28.

Figure 27 : Monitor Loudspeaker.

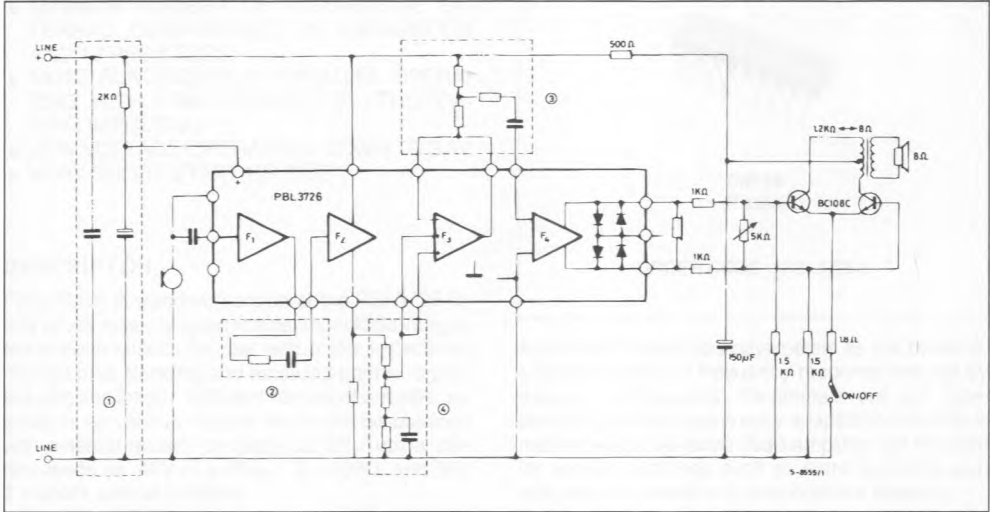

TWO - WAY COMMUNICATION (SEND/RECEIVE)

Figure 28 : Trunk Interface Applications.

