



Automotive Motor Control Development Solutions

3-Phase Sensorless BLDC Kit with Qorivva MPC5606B MCU

Target Automotive Applications

- Doors, window lift and seat control
- Electric pumps, motor control and auxiliaries
- Heating, ventilation and air conditioning (HVAC)
- Transmission and gearbox

Overview

This development kit featuring the Qorivva MPC5606B MCU helps you to get your development started within minutes. You don't need to wait for your own hardware design to be available, nor start software development from scratch. This development kit offers you a fully documented working setup for 3-phase sensorless brushless DC (BLDC) motor control.

The hardware consists of one MPC5606B controller board, featuring the MC33905D system basis chip, connected to a power stage board with the MC33937A MOSFET pre-driver onboard.

The application software available in this development kit provides a complete, easy-to-

use solution for the BLDC sensorless motor control applications, covering speed control and torque limitation.

The complete hardware and software documentation will help you use and adapt this solution for your own application use cases.

3-Phase Sensorless BLDC Kit

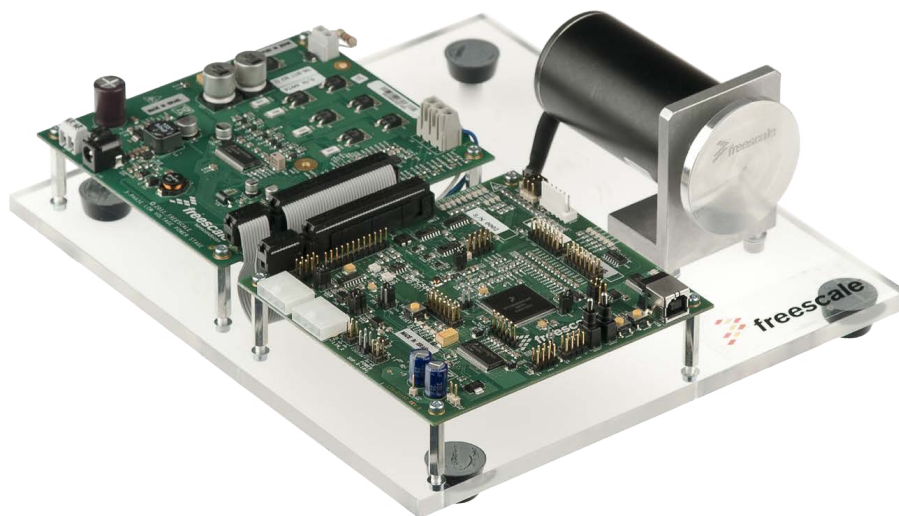

Development Kit Features

- MPC560xB controller board
- 3-phase BLDC/PMSM low-voltage power stage (10 A) based on the SMARTMOS MC33937A FET pre-driver
- 24 V BLDC motor
- FreeMASTER tool for instrumentation/ visualization
- Sensorless control using back EMF zero-crossing detection
- DC-bus overvoltage, overcurrent and undervoltage fault detection
- Hardware support for Hall sensor-based motor control

Qorivva MPC5606B MCU Features

- Up to 64 MHz e200z0 core, 32-bit Power Architecture® CPU
- 1 MB of code flash, 64 KB of data flash, 80 KB of SRAM (all with ECC)
- Six FlexCAN and up to eight LINFlex modules
- Two 32-channel enhanced modular I/O submodules (eMIOS)
- 10-bit ADC and 12-bit ADC modules with total 39 channels expandable to 67 channels via external multiplexing
- 8-channel periodic interrupt timer (PIT)
- Cross triggering unit with 64 input channels

MC33937A Features

- Fully specified from 8.0 to 40 V covering 12 and 24 V automotive systems
- Extended operating range from 6.0 to 58 V covers 12 and 42 V systems
- Greater than 1.0 A gate drive capability with protection
- Protection against reverse charge injection from C_{GD} and C_{GS} capacitances of external FETs
- SPI programmable dead time
- Simultaneous output capability enabled via safe SPI command

MC33905D Features

- 5.0 or 3.3 V voltage regulator with current, temperature and voltage protection
- Single CAN and two LIN transceivers
- Advanced SPI, MCU, ECU power supply and critical pin diagnostics and monitoring
- Extremely low quiescent current in low power modes

Motor Control Algorithm Concept

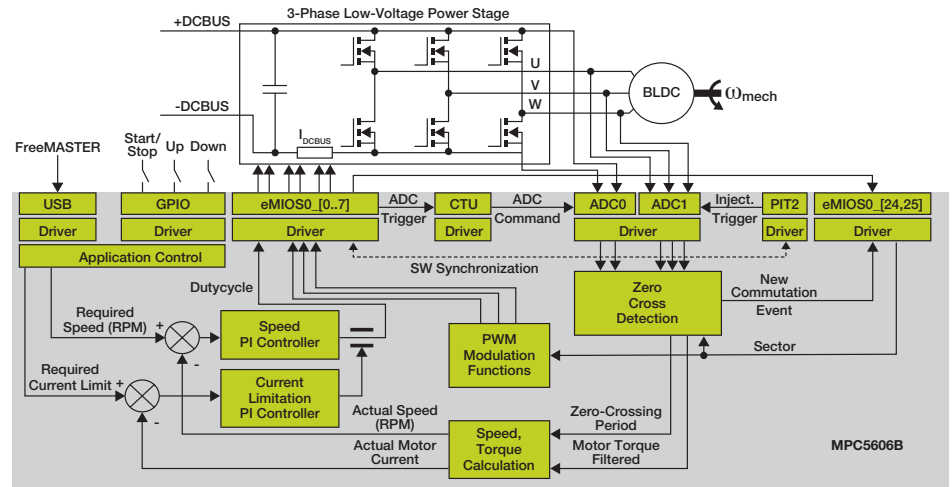

FreeMASTER Project Page

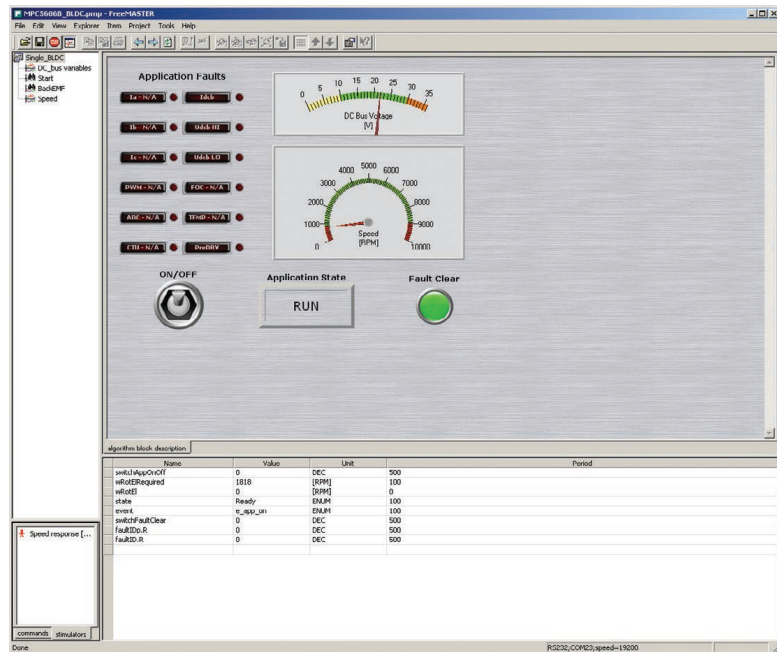

For more information, visit freescale.com/automcdevkits