

COS/MOS INTEGRATED CIRCUITS



ADVANCE DATA

LOOP DISCONNECT DIALLER

- DIRECT TELEPHONE LINE OPERATION
- LOW VOLTAGE COS/MOS TECHNOLOGY
- LOW POWER CONSUMPTION IN STAND-BY MODE
- PIN SELECTABLE LONG DISTANCE CALL INHIBITION
- PIN SELECTABLE OUTPUT PULSING INHIBITION
- 8 SELECTABLE ACCESS PAUSES
- WIDE SELECTION OF MASK OPTIONS FOR 1.5-1.6-1.66-2 B/W RATIOS

The M760 Loop Disconnect Dialler provides the features to implement a pulse dialler with redial. It can be operated directly by the telephone line current and convert a single per key contact into the corresponding pulse signals to simulate the rotary dialler.

When in stand-by condition it requires only few microamperes to maintain the storage of the last call. Keyboard inputs are fully static; outputs are provided to pulse the telephone line and to mute the receiver during impulsing.

Other features are: pin selectable long distance call inhibition, 24 digit memory in which can be introduced a maximum of 8 access pauses, pin selectable redial inhibition and out pulsing inhibition for operation with payment-card telephones.

Redial can be achieved with two pin selectable procedures.

The device requires an inexpensive 455 kHz ceramic resonator and is designed to minimize external components.

The unique design of the power-on reset circuit can avoid the need for a special dedicated spring in the hook switch.

The loop is disconnected for a time longer than 300 msec when fraudulent dialling is tried with the hook or any external device by sensing the line condition at the input LS.

The M760 is realized in low voltage COS/MOS technology and can be easily mask programmed to meet all administration standards; it is available in a 24 pin dual in-line plastic or ceramic package; the M760A is available in 18 pin dual in-line plastic or ceramic package.

ABSOLUTE MAXIMUM RATINGS*

V_{DD}^{**}	Supply voltage	5	V
V_i	Input voltage	$V_{SS} - 0.5$ to $V_{DD} + 0.5$	V
P_{tot}	Total power dissipation	400	mW
T_{op}	Operating temperature range	-25 to +50	°C
T_{stg}	Storage temperature range	-65 to +85	°C

* Stresses above those listed under "Absolute Maximum Ratings" may cause permanent damage to the device. This is a stress rating only and functional operation of the device at these or any other conditions above those indicated in the operational sections of this specification is not implied. Exposure to absolute maximum rating conditions for extended periods may affect device reliability.

** All voltages are referred to V_{SS} pin voltage.

ORDERING NUMBERS: M760 B1 for dual in-line plastic package
M760A B1 for dual in-line ceramic package (frit seal)
M760 F1 for dual in-line plastic package
M760A F1 for dual in-line ceramic package (frit seal)



M 760
M 760A

MECHANICAL DATA (dimensions in mm)

Dual in-line plastic package (M760)

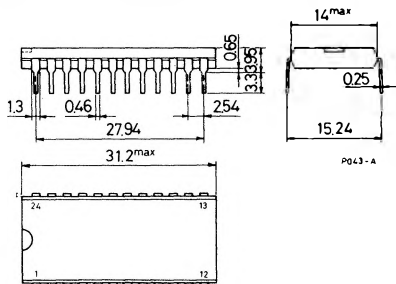

Dual in-line ceramic frit seal package (M760)

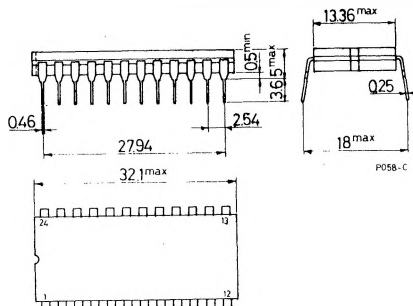

Dual in-line plastic package (M760A)

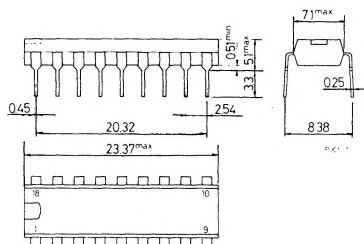

Dual in-line ceramic frit seal package (M760A)

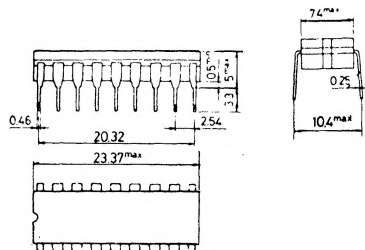

PIN CONNECTIONS

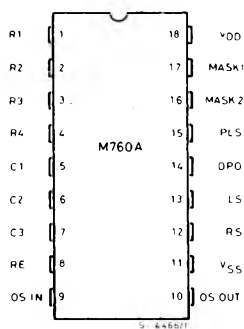
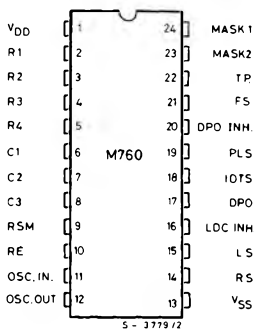

BLOCK DIAGRAM

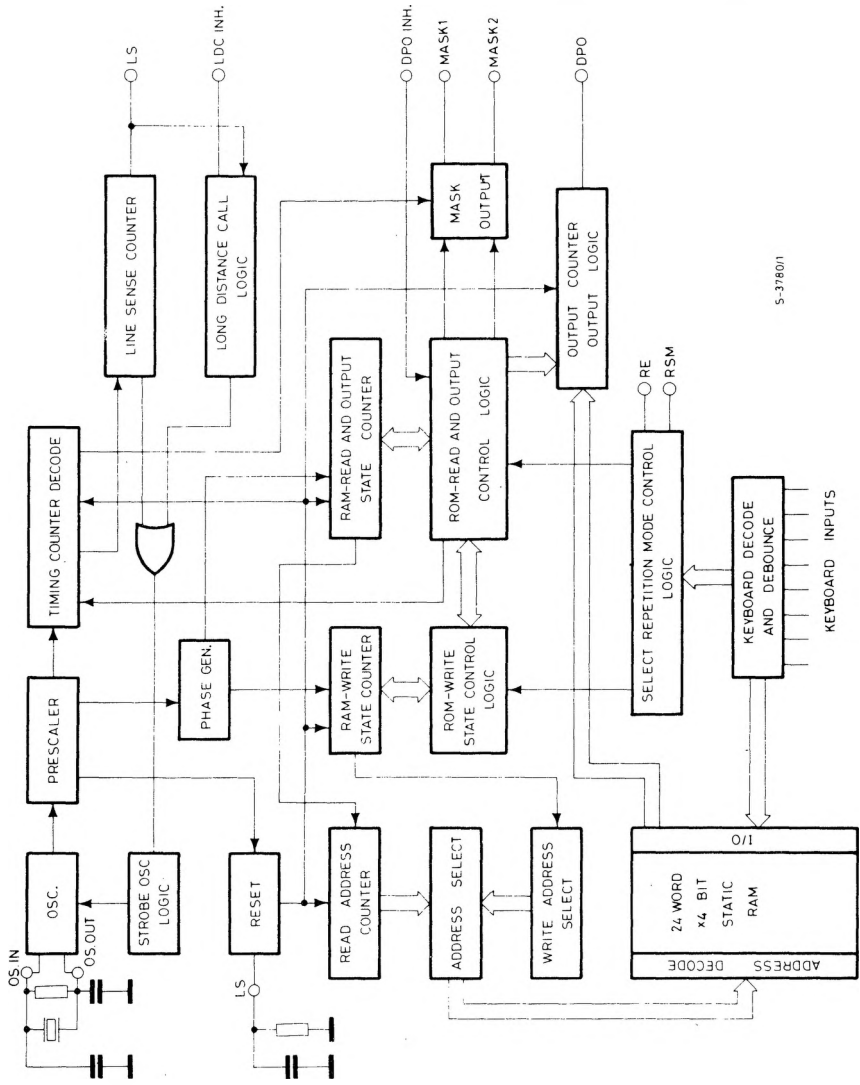

5-37801





M 760
M 760A

STATIC ELECTRICAL CHARACTERISTICS ($T_{op} = -25^{\circ}\text{C}$ to $+50^{\circ}\text{C}$)

	Parameter	Test conditions	Min.	Typ.	Max.	Unit	
Supply	V_{DD} Supply voltage		2.2	2.5	5	V	
	I_{DD} Operating supply current	$V_{DD} = 2.5\text{V}$ $f_0 = 455\text{ kHz}$			0.5	mA	
	I_{DD} Stand-by supply current (oscillator off, no external load connected)	$V_{DD} = 2.5\text{V}$			25	μA	
Keyboard inputs	Row inputs						
	I_{nH} Input high current	$V_{DD} = 2.5\text{V}$ $V_{IH} = 2.5\text{V}$ $V_{IL} = 0\text{V}$		60	80	μA	
	I_{nL} Input low current				-1	μA	
	V_{IH} Input threshold voltage		1			V	
	Column inputs						
	I_{IH} Input high current	$V_{DD} = 2.5\text{V}$ $V_{IH} = 2.5\text{V}$ $V_{IL} = 0\text{V}$			1	μA	
	I_{IL} Input low current			-60	μA		
	V_{IL} Input threshold voltage				$V_{DD}-1\text{V}$	V	
Oscillator	OSC IN						
	I_H Input high current	$V_{DD} = 2.5\text{V}$ $V_{IH} = 2.5\text{V}$			1	μA	
	I_L Input low current	$V_{IL} = 0\text{V}$			-1	μA	
	OSC OUT						
	I_{OH} Output drive current	$V_{DD} = 2.5\text{V}$ $V_{OH} = 2\text{V}$	-150			μA	
	I_{OL} Output sink current	$V_{DD} = 2.5\text{V}$ $V_{OL} = 0.5\text{V}$	150			μA	
Mask output	I_{OH} Output drive current	$V_{DD} = 2.2\text{V}$ $V_{OH} = 1.4\text{V}$	-1			mA	
	I_{OL} Output sink current	$V_{DD} = 2.2\text{V}$ $V_{OL} = 0.1\text{V}$		20		μA	
DPO	I_{OL} Output sink current	$V_{DD} = 2.2\text{V}$ $V_{OL} = 0.4\text{V}$	1			mA	
	I_{OFF} Output leakage current	$V_{DD} = 2.5\text{V}$			+1	μA	
LDC INH DPO INH PLS RSM RE	I_{IH} Input high current	$V_{DD} = 2.5\text{V}$ $V_{IH} = 2.5\text{V}$			1	μA	
	I_{IL} Input low current	$V_{DD} = 2.5\text{V}$ $V_{IL} = 0\text{V}$			-1	μA	
	V_{IH} Input high voltage		$0.7V_{DD}$			V	
	V_{IL} Input low voltage				$0.3V_{DD}$	V	
LS	I_{IH} Input high current	$V_{DD} = 2.5\text{V}$ $V_{IH} = 2.5\text{V}$			1	mA	
	I_{IL} Input low current	$V_{DD} = 2.5\text{V}$ $V_{IL} = 0\text{V}$		-100	-250	mA	
	V_{IH} Input high voltage		$0.7V_{DD}$			V	
	V_{IL} Input low voltage				$0.3V_{DD}$	V	
RS	I_{OH} Output drive current	$V_{DD} = 2.5\text{V}$ $V_{OH} = 1.8\text{V}$	-20			mA	
	I_{OL} Output leakage current				1	mA	
	V_{IH} Input high voltage		$0.8V_{DD}$			V	
	V_{IL} Input low voltage				$0.2V_{DD}$	V	



M 760
M 760A

DYNAMIC ELECTRICAL CHARACTERISTICS ($T_{op} = -25$ to $+50^{\circ}\text{C}$)

Parameter		Test conditions	Min.	Typ.	Max.	Unit
t_{ACC}	Key access time after last bounce	for all $f_o = 455$ kHz $V_{DD} = 2.5\text{V}$		5.5		ms
t_{OSC}	Oscillator start-up time				60	ms
t_{MASK}	Mask 1, Mask 2 pulse duration			20		ms
t_{DM}	Mask 1, Mask 2 delay time with respect to DPO			50		ms
t_{PD}	Pre-digital pause			400		ms
t_{DPO}	DPO period		FS = 0 FS = 1		50 100	ms ms
t_B/t_M	Break to make ratio				1.6	
t_{IDT}	Interdigit time		IDTS = 0 IDTS = 1		800 400	ms ms
t_{RES}	Minimum line break before reset				150	ms
t_{OTO}	Oscillator turn-off time after clear-down. LDC Inh = 0 LDC Inh = 1				150 300	ms ms
$t_{LDC\ Inh}$	Line break time when LDC Inh = 1			300	ms	



M 760
M 760A

FUNCTIONAL DESCRIPTION

Oscillator (OS IN – OS OUT)

The oscillator has been designed to work with an inexpensive ceramic resonator; ($f_o = 455$ kHz) it requires two external load capacitors (100 pF) and the inverter feedback resistance. The oscillator starts after LS (line sens) is taken low; it comes back to the stand-by mode after LS has gone high for at least 150 ms (or 300 ms if LDC-INH high).

Keyboard (R_1 to R_4 , C_1 to C_3)

M760 is designed to work with a single contact keyboard.

A valid key entry is recorded when a single row pin is connected to a single column pin.

All the input combinations except a single row and a single column are not recognized.

A valid key is entered after 5 ms from the last key bounce.

Outpulsing inhibition (DPO, INH)

If this pin is low, digits can be entered into the memory but they are not sent on the line; when DPO INH goes high the stored digits are sent on the line.

This function is realized to allow operations with payment-card telephones in which it is sometimes needed to assess the validity of the payment-card.

Dial pulse output (DPO)

When a valid key is recognized the line must be opened and closed at a fixed rate and the total number of break pulses corresponds to the number of the selected key (10 line breaks are associated to the key "0").

DPO is an open drain output; line breaks occur when DPO is active to ground.

Mask Outputs (MASK 1, MASK 2)

The Mask outputs are used to mute the speech circuit during signalling.

In telephones using conventional speech circuits muting is generally achieved by short-circuiting with a two-winding, bistable reed-relay. In this case MASK 1 and MASK 2 provide pulse outputs to drive the winding which close and open the contact respectively.

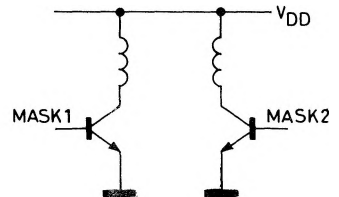
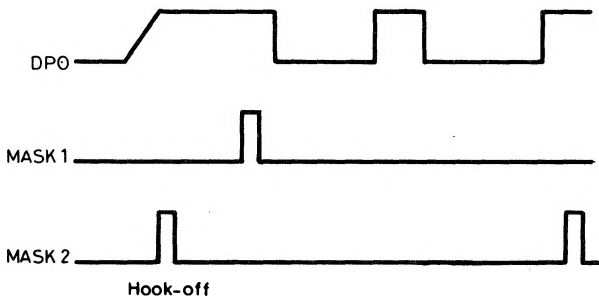

FUNCTIONAL DESCRIPTION (continued)

In telephones with electronic speech circuits muting is implemented electronically. In this case a metal option transforms MASK 1 into a signal which remains high throughout signalling.

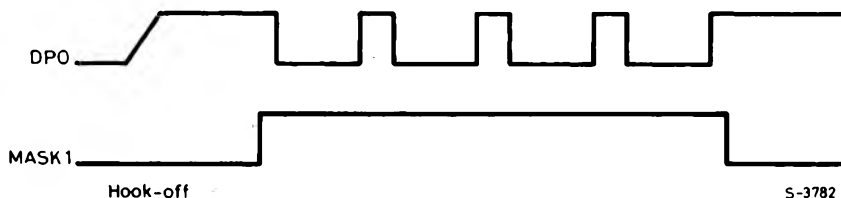

Redial enable (RE)

Redial of the last call is possible according to the procedures described below only if RE is high. Redial is never allowed when RE is low.

Redial Selection Mode (RSM)

The last number redialling facility operates in two modes. In the first (RSM high) the key sequence **0 will repeat the last number dialled. The last number memory can be cleared by the # key.

In the second case (RSM low) the last number dialled is only stored if the key * is pressed before replacing the handset. As before, the sequence **0 starts the last number repeat.

In both cases the stored number is unaffected by incoming calls.

The redial request can be simplified by a mask option to the single key *, instead of the sequence **0.

Pause length selection (PLS)

Interdigit pauses are available to interrupt outpulsing to give to the exchange the possibility of switching from a private to a public line.

The device memorizes automatically a pause when the first digit is 0; a maximum of 7 pauses can be added during dialing by selecting key *.

These pauses are active only during redialing and have a duration of 3 sec if PLS is low or 20 sec if PLS is high; in both cases pause duration can be shortened pushing key *.

Line sense (LS)

This input senses if the line loop is closed or not

LS = high means loop open
 LS = low means loop closed

When LS is kept high for more than 150 ms the circuit is reset (if LDC INH = 0).

When LDC INH = 1 reset occurs after 300 ms.



M Z60
M Z60A

FUNCTIONAL DESCRIPTION (continued)

Reset (RS)

This input/output pin is used to turn off the oscillator when line interrupts of more than 150 ms are sensed; it is also used as a power-on reset in applications where redial is not allowed.

When the hand-set is picked-up and V_{DD} increases over its minimum value, the oscillator starts and an external capacitor is charged above a fixed threshold level by an open drain P-ch. transistor driven by a 150 kHz clock.

Reset occurs after a line interrupt of more than 150 ms; the pull-up transistor goes off and the capacitor discharges through a resistance to GND level.

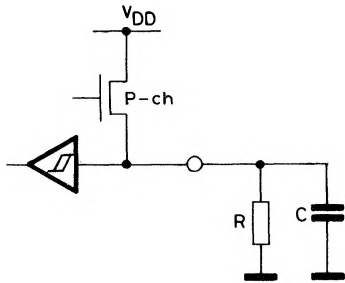

S-3783

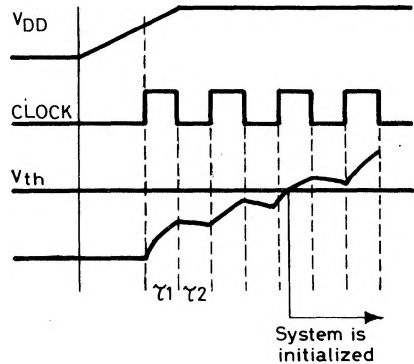

Long distance call inhibit (LDC INH)

When this input is taken high long distance calls are inhibited; if the first digit is a 0 DPO goes low interrupting the line for a time longer than 300 ms.

The same applied when fraudulent dialing is tried with the hook or any external device by sensing the line condition at the input LS.

When INH is low this facility is inoperative.

Test pin (TP)

When this input is taken low all the timing values are divided by 100. In this way the length of the testing operations is greatly reduced. This pin has an internal pull-up.



TYPICAL APPLICATIONS

Typical serial applications

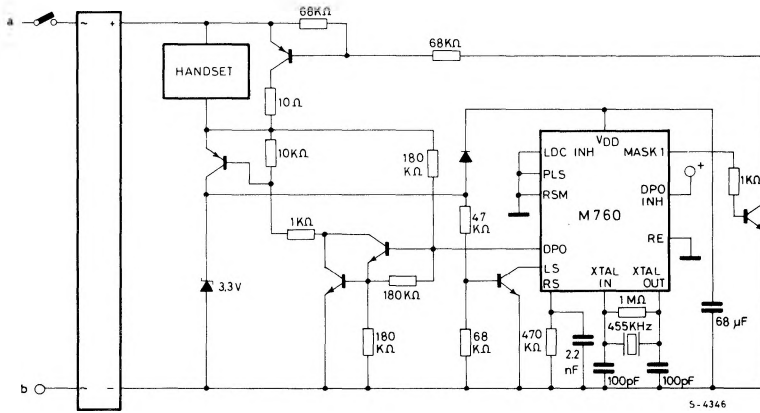

With bistable rele

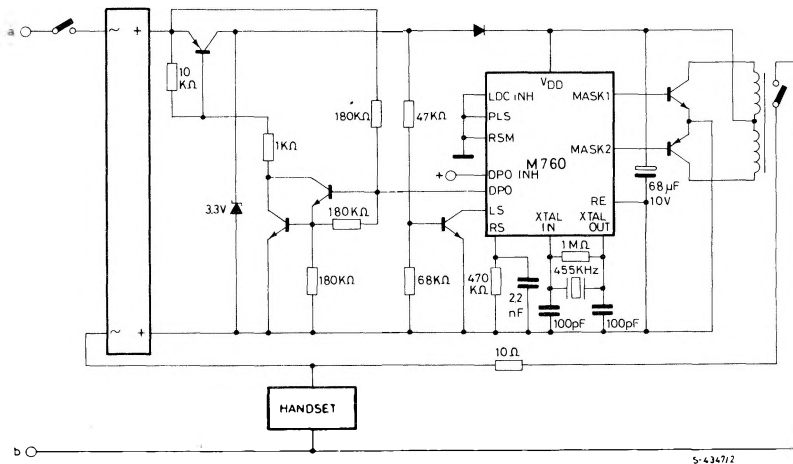



M 760
M 760A

TYPICAL APPLICATIONS (continued)

Pulse dialler with redial

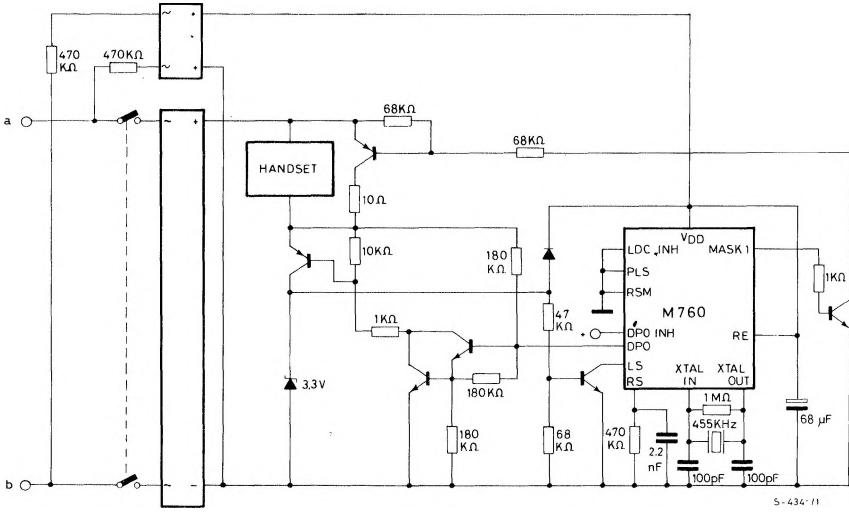

TIMING DIAGRAM

