



LED DISPLAY DRIVER

- 3 1/2 DIGIT LED DRIVER (23 segments)
- CURRENT GENERATOR OUTPUTS (no resistors required)
- CONTINUOUS BRIGHTNESS CONTROL
- SERIAL DATA INPUT
- NO LOAD SIGNAL REQUIRED
- WIDE SUPPLY VOLTAGE OPERATION
- TTL COMPATIBILITY

Applications examples :

- MICROPROCESSOR DISPLAYS
- INDUSTRIAL CONTROL INDICATION
- RELAY DRIVER
- INSTRUMENTATION READOUTS

DESCRIPTION

The M5480 is a monolithic MOS integrated circuit produced with a N-channel silicon gate technology. It utilizes the M5451 die packaged in a 28-pin plastic package making it ideal for a 3 1/2 digit display. A single pin controls the LED display brightness by

setting a reference current through a variable resistor connected either to V_{DD} or to a separate supply of 13.2V maximum.

The M5480 is a pin-to-pin replacement of the NS MM 5480.



CONNECTION DIAGRAM

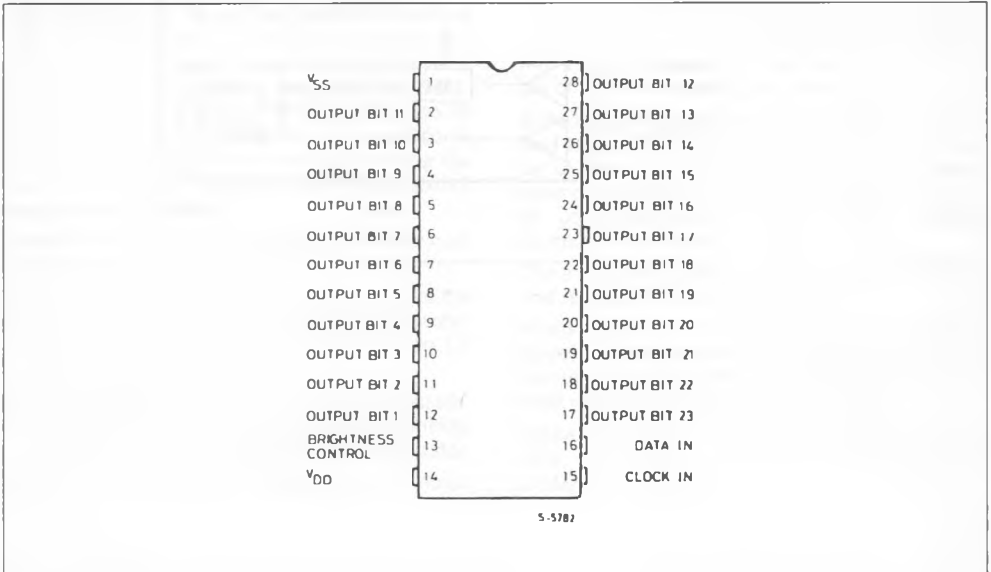

ABSOLUTE MAXIMUM RATINGS

| Symbol | Parameter | Value | Unit | |
|--------------|---------------------------------|-------------|------|----|
| V_{DD} | Supply Voltage | - 0.3 to 15 | V | |
| V_I | Input Voltage | - 0.3 to 15 | V | |
| $V_{O(off)}$ | Off State Output Voltage | 15 | V | |
| I_O | Output Sink Current | 40 | mA | |
| P_{Tot} | Total Package Power Dissipation | at 25 °C | 940 | mW |
| | | at 85 °C | 490 | mW |
| T_j | Junction Temperature | 150 | °C | |
| T_{op} | Operating Temperature Range | - 25 to 85 | °C | |
| T_{stg} | Storage Temperature Range | - 65 to 150 | °C | |

Stresses in excess of those listed under "Absolute Maximum Ratings" may cause permanent damage to the device. This is a stress rating only and functional operation of the device at these or any other conditions in excess of those indicated in the operational sections of this specification is not implied. Exposure to absolute maximum rating conditions for extended periods may affect device reliability.

BLOCK DIAGRAM

Figure 1.

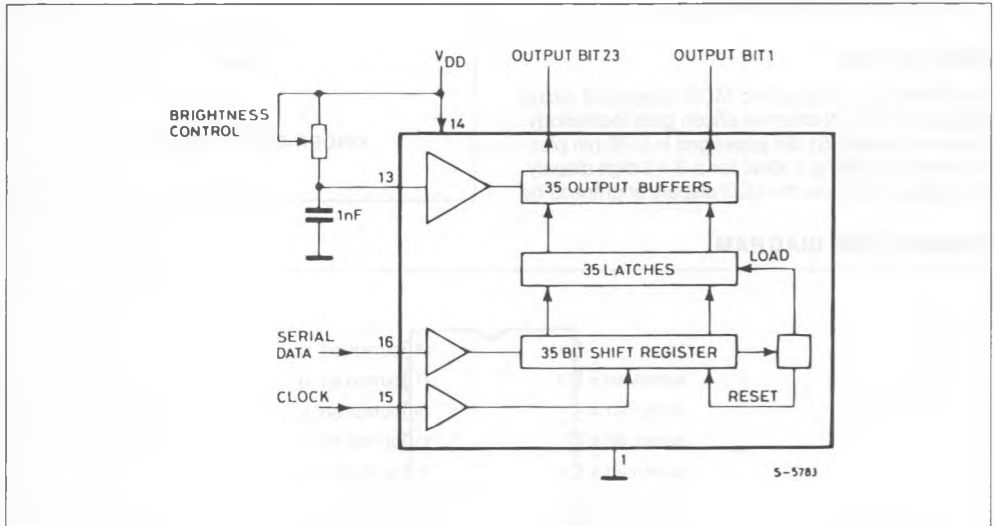

STATIC ELECTRICAL CHARACTERISTICS (T_{amb} within operating range, $V_{DD} = 4.75$ V to 13.2 V, $V_{SS} = 0$ V, unless otherwise specified)

| Symbol | Parameter | Test Conditions | Min. | Typ. | Max. | Unit |
|--------------|---|---|------------------------------|-----------|-----------------------------|---------------------|
| V_{DD} | Supply Voltage | | 4.75 | | 13.2 | V |
| I_{DD} | Supply Current | $V_{DD} = 13.2$ V | | | 7 | mA |
| V_i | Input Voltages Logical "0" Level Logical "1" Level | ± 10 μ A Input Bias $4.75 \leq V_{DD} \leq 5.25$ $V_{DD} > 5.25$ | - 0.3 2.2 $V_{DD} - 2$ | | 0.8 V_{DD} V_{DD} | V V V |
| I_B | Brightness Input Current (note 2) | | 0 | | 0.75 | mA |
| V_B | Brightness Input Voltage (pin 13) | Input Current = 750 μ A | 3 | | 4.3 | V |
| $V_{O(off)}$ | Off State Output Voltage | | | 13.2 | 18 | V |
| I_O | Output Sink Current (note 3) Segment OFF Segment ON | $V_O = 3$ V $V_O = 1$ V (note 4) Brightness In. = 0 μ A Brightness In. = 100 μ A Brightness In. = 750 μ A | 0 2 12 | 2.7 15 | 10 10 25 | μ A mA mA |
| f_{clock} | Input Clock Frequency | | 0 | | 0.5 | MHz |
| I_O | Output Matching (note 1) | | | | ± 20 | % |

- Notes :**
- Output matching is calculated as the percent variation from $|I_{max} + I_{min}|/2$.
 - With a fixed resistor on the brightness input some variation in brightness will occur from one device to another.
 - Absolute maximum for each output should be limited to 40 mA.
 - The V_O voltage should be regulated by the user.

FUNCTIONAL DESCRIPTION

The M5480 is specifically designed to operate 3 1/2 digit alphanumeric displays with minimal interface with the display and the data source. Serial data transfer from the data source to the display driver is accomplished with 2 signals, serial data and clock. Using a format of a leading "1" followed by the 35 data bits allows data transfer without an additional load signal. The 35 data bits are latched after the 36th bit is complete, thus providing non-multiplexed, direct drive to the display.

Outputs change only if the serial data bits differ from the previous time.

Display brightness is determined by control of the output current for LED displays. A 1nF capacitor should be connected to brightness control, pin 13, to prevent possible oscillations.

A block diagram is shown in figure 1. The output current is typically 20 times greater than the current into pin 13, which is set by an external variable resistor.

There is an internal limiting resistor of 400 Ω nominal value.

Figure 2 shows the input data format. A start bit of logical "1" precedes the 35 bits of data. At the 36th clock a LOAD signal is generated synchronously with the high state of the clock, which loads the 35 bits of the shift registers into the latches.

At the low state of the clock a RESET signal is generated which clears all the shift registers for the next set of data. The shift registers are static master-slave configurations. There is no clear for the master portion of the first register, thus allowing continuous operation.

There must be a complete set of 36 clocks or the shift registers will not clear.

When power is first applied to the chip an internal power ON reset signal is generated which resets all registers and all latches. The START bit and the first clock return the chip to its normal operation.

Figure 3 shows the timing relationships between Data, and Clock. A maximum clock frequency of 0.5 MHz is assumed.

FUNCTIONAL DESCRIPTION

Figure 4 shows the Output Data Format for the 5480. Because it uses only 23 of the possible 35 outputs, 12 of the bits are "Don't Care".

For applications where a lesser number of outputs are used, it is possible to either increase the current per output, or operate the part at higher than 1V V_{OUT}.

The following equation can be used for calculations.

$$T_j = [(V_{OUT}) (I_{LED}) (\text{No. of segments}) + V_{DD} \cdot 7 \text{ mA}] (132 \text{ }^\circ\text{C/W}) + T_{amb}$$

where:

T_j = junction temperature (150 °C max)

V_{OUT} = the voltage at the LED driver outputs

I_{LED} = the LED current

132 °C/W = thermal coefficient of the package

T_{amb} = ambient temperature

Figure 2 : Input Data Format.

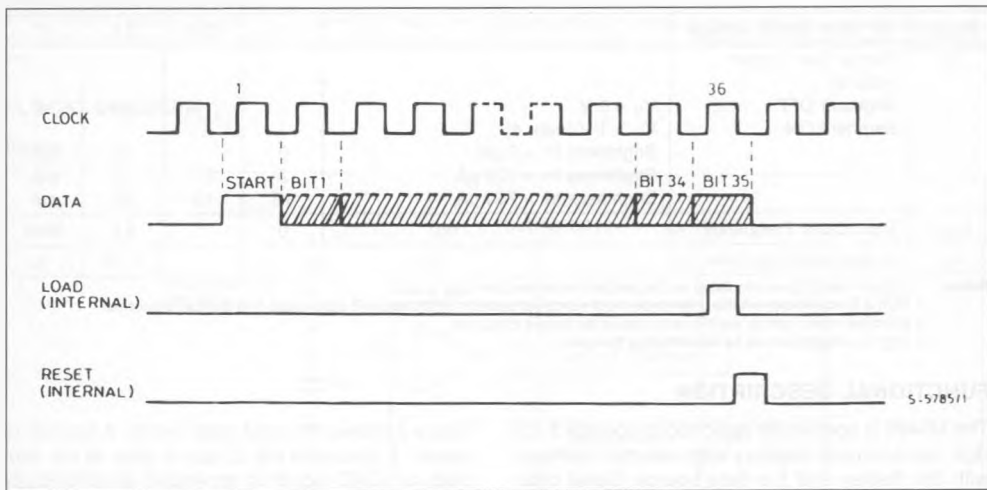

Figure 3 .

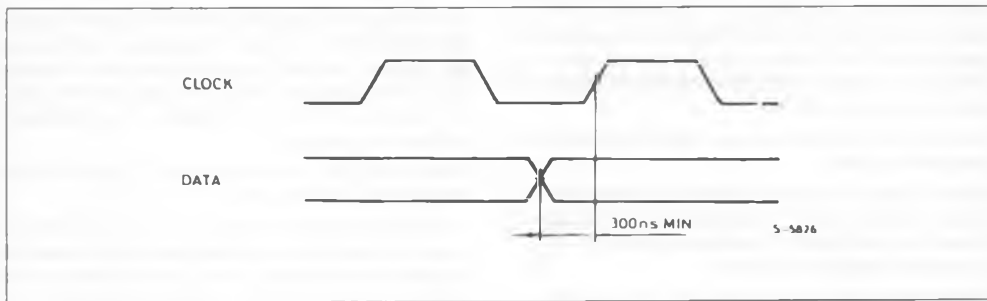

Figure 4 : Serial Data Bus / Outputs Correspondence.

| | | | | | | | | | | | | | | | | | | |
|------|----|----|----|----|----|----|----|----|----|----|----|----|----|----|----|----|----|-------|
| 5451 | 35 | 34 | 33 | 32 | 31 | 30 | 29 | 28 | 27 | 26 | 25 | 24 | 23 | 22 | 21 | 20 | 19 | START |
| 5480 | X | 23 | 22 | 21 | 20 | 19 | X | X | 18 | X | 17 | 16 | 15 | 14 | 13 | 12 | X | START |

| | | | | | | | | | | | | | | | | | | | |
|------|----|----|----|----|----|----|----|----|----|---|---|---|---|---|---|---|---|---|-------|
| 5451 | 18 | 17 | 16 | 15 | 14 | 13 | 12 | 11 | 10 | 9 | 8 | 7 | 6 | 5 | 4 | 3 | 2 | 1 | START |
| 5480 | X | X | X | 11 | 10 | 9 | 8 | X | X | X | 7 | 6 | 5 | 4 | 3 | 2 | 1 | X | START |

TYPICAL APPLICATION

BASIC 3 1/2 Digit Interface.

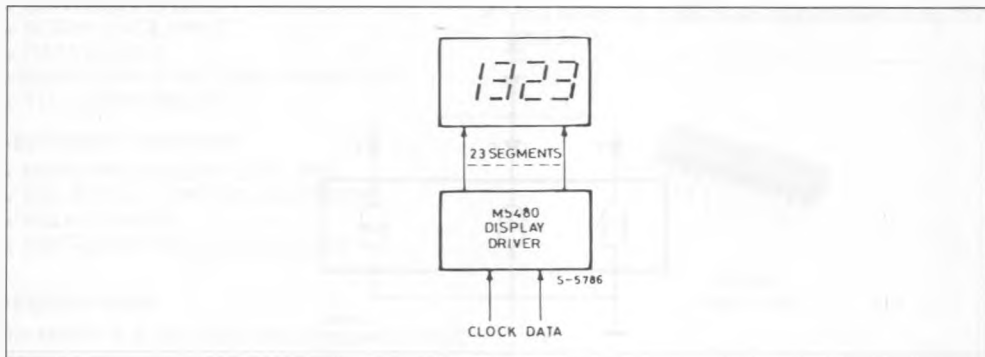

POWER DISSIPATION OF THE IC

The power dissipation of the IC can be limited using different configurations.

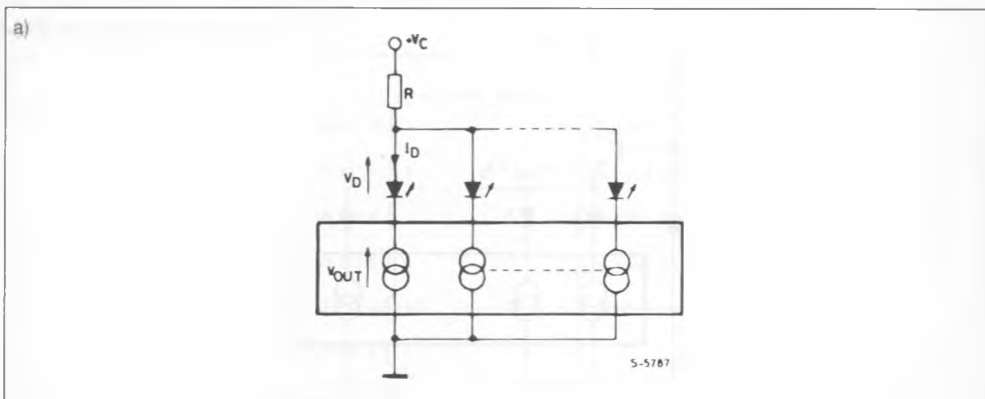

In this application R must be chosen taking into account the worst operating conditions.

R is determined by the maximum number of segments activated.

$$R = \frac{V_C - V_{D \text{ MAX}} - V_{OUT \text{ MIN}}}{N_{\text{MAX}} \cdot I_D}$$

The worst case condition for the device is when roughly half of the maximum number of segments are activated.

It must be checked that the total power dissipation does not exceed the absolute maximum ratings of the device.

In critical cases more resistors can be used in conjunction with groups of segments.

In this case the current variation in the single resistor is reduced and P_{tot} limited.

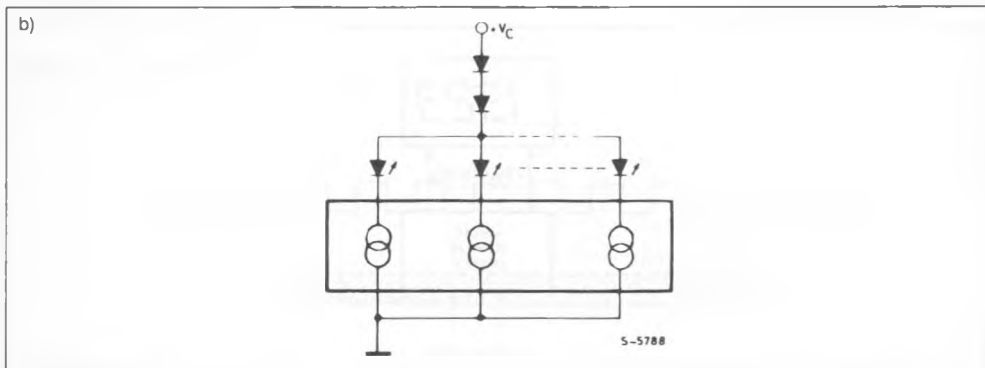

In this configuration the drop on the serial connected diodes is quite stable if the diodes are properly chosen. The total power dissipation of the IC depends, in a first approximation, only on the number of segments activated.

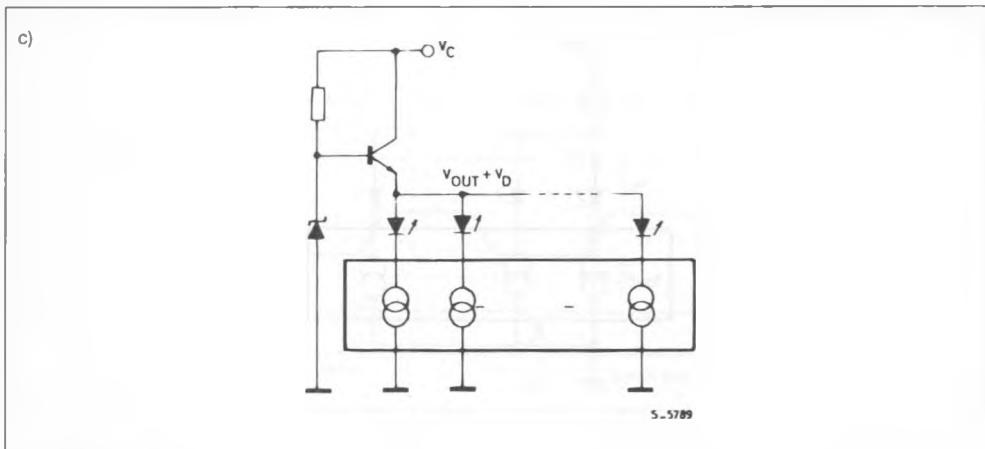

In this configuration $V_{OUT} + V_D$ is constant. The total power dissipation of the IC depends only on the number of segments activated.