

# Double cassette tape recorder system preamplifier

## BA3426S

The BA3426S is a record/playback system preamplifier for radio cassette decks. It also has a CD input. It has three control switches for function and tape mode switching and mic on/off. It requires far fewer external components than its predecessors which means simplified assembly and overall savings.

### ● Applications

Dual-cassette radio cassette players.

### ● Features

- 1) Built-in switch for recording/playback equalize.
- 2) Motor control output provided.
- 3) CD input.
- 4) Smoothing capacitors to suppress switching noise are not required.
- 5) Built-in bias oscillator transistor.

### ● Absolute maximum ratings (Ta = 25°C)

| Parameter             | Symbol           | Limits   | Unit |
|-----------------------|------------------|----------|------|
| Supply voltage        | V <sub>cc</sub>  | 9        | V    |
| Power dissipation     | P <sub>d</sub>   | 1250*1   | mW   |
| Operating temperature | T <sub>opr</sub> | -10~+75  | °C   |
| Storage temperature   | T <sub>stg</sub> | -55~+125 | °C   |

\* Reduced by 12.5mW for each increase in Ta of 1°C over 25°C.

### ● Recommended operating conditions (Ta = 25°C)

| Parameter      | Symbol          | Min. | Typ. | Max. | Unit |
|----------------|-----------------|------|------|------|------|
| Supply voltage | V <sub>cc</sub> | 4.5  | —    | 7.0  | V    |

● Block diagram

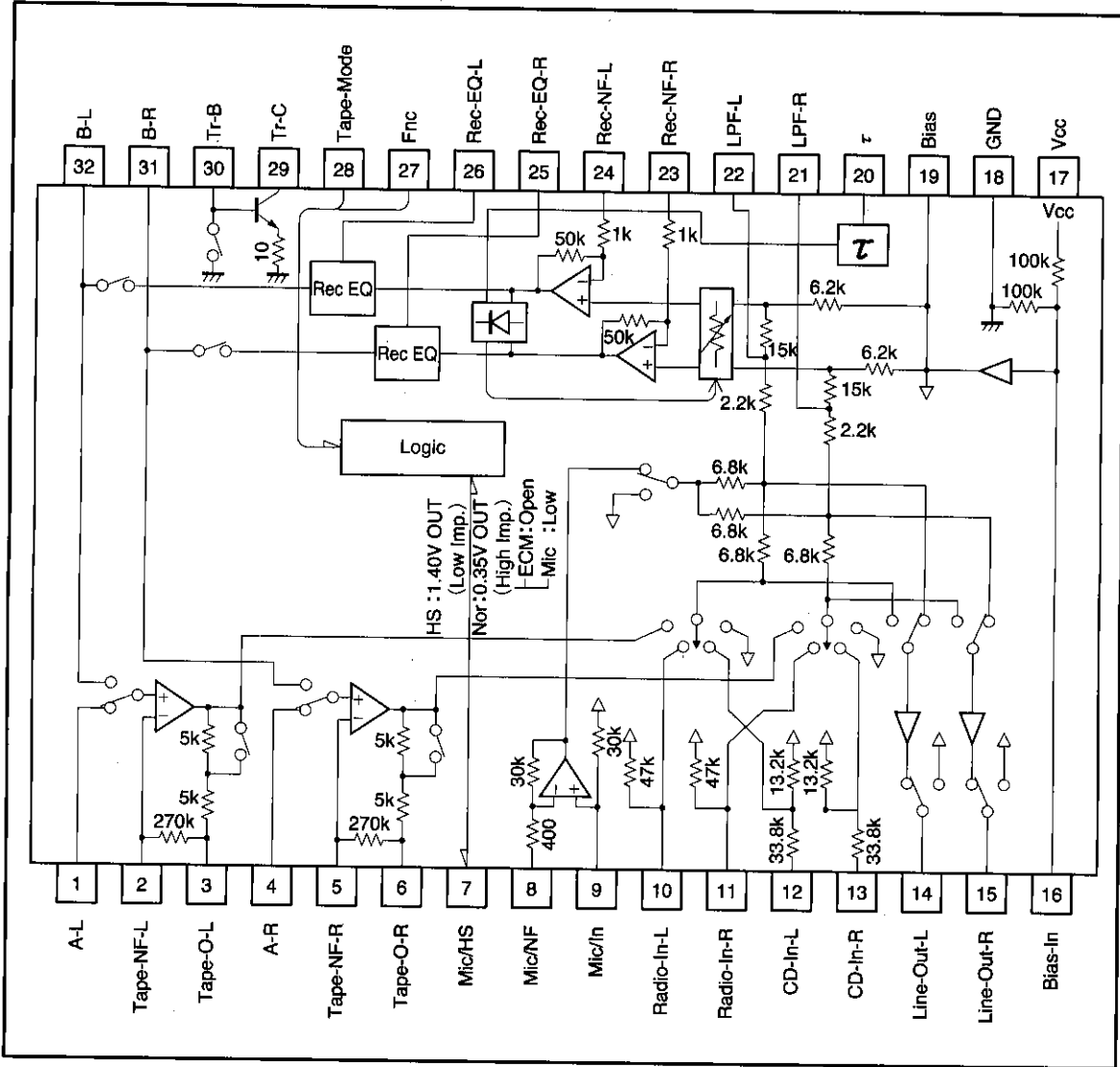

Low-frequency amplifiers  Preamplifiers

## ● Pin connections

| Pin No. | Pin name   | Function   |
|---------|------------|--|
| 1       | A-L        | Tape A input (L ch)  |
| 2       | Tape-NF-L  | Playback equalizer amplifier negative input (L ch)           |
| 3       | Tape-O-L   | Playback equalizer amplifier output (L ch)                   |
| 4       | A-R        | Tape A input (R ch)  |
| 5       | Tape-NF-R  | Playback equalizer amplifier negative input (R ch)           |
| 6       | Tape-O-R   | Playback equalizer amplifier output (R ch)                   |
| 7       | Mic/HS     | Int/Ext mic switch, motor control                            |
| 8       | Mic-NF     | Microphone amplifier negative input                          |
| 9       | Mic-IN     | Microphone amplifier input                                   |
| 10      | Radio-IN-L | Radio input (L ch)   |
| 11      | Radio-IN-R | Radio input (R ch)   |
| 12      | CD-IN-L    | CD input (L ch)  |
| 13      | CD-IN-R    | CD input (R ch)  |
| 14      | Line-Out-L | Line amplifier (L ch)  |
| 15      | Line-Out-R | Line amplifier (R ch)  |
| 16      | Bias-IN    | Bias input   |
| 17      | Vcc        | Power supply   |
| 18      | GND        | Substrate GND  |
| 19      | Bias       | Operating reference point                                    |
| 20      | $\tau$     | Transient mute, ALC time constant                            |
| 21      | LPF-R      | Low-pass filter (R ch)                                       |
| 22      | LPF-L      | Low-pass filter (L ch)                                       |
| 23      | Rec-NF-R   | ALC amplifier negative feedback (R ch)                       |
| 24      | Rec-NF-L   | ALC amplifier negative feedback (L ch)                       |
| 25      | Rec-EQ-R   | Recording equalizer amplifier negative feedback (R ch)       |
| 26      | Rec-EQ-L   | Recording equalizer amplifier negative feedback (L ch)       |
| 27      | Fnc        | Function switch  |
| 28      | Tape-Mode  | Tape mode switch   |
| 29      | Tr-C       | Bias oscillator transistor (collector)                       |
| 30      | Tr-B       | Bias oscillator transistor (base)                            |
| 31      | B-R        | Tape B input and recording equalizer amplifier output (R ch) |
| 32      | B-L        | Tape B input and recording equalizer amplifier output (L ch) |

- Electrical characteristics (Unless otherwise specified;  $T_a = 25^\circ\text{C}$ ,  $V_{cc} = 5.5\text{V}$ ,  $f = 1\text{kHz}$ ,  $R_g = 680\Omega$ ,  
Tape input =  $-66\text{dB}$ , Mic. input =  $-50\text{dB}$ , and Radio input =  $-23\text{dB}$ , and CD input =  $-12\text{dB}$ )

| Parameter                             | Symbol     | Min. | Typ. | Max. | Unit             | Symbol* | Conditions                     |
|---------------------------------------|------------|------|------|------|------------------|---------|--------------------------------|
| Circuit current                       | $I_o$      | —    | 28   | 36   | mA               | TAE     |                                |
| Voltage gain                          |            |      |      |      |                  |         |                                |
| Mic ~Line                             | GvcML      | 28   | 31   | 34   | dB               | TNM     |                                |
| Radio~Line                            | GvcRL      | 1    | 4    | 7    | dB               | RAE     |                                |
| CD ~Line                              | GvcCL      | -10  | -7   | -4   | dB               | CAE     |                                |
| Radio~Rec                             | GvcRR      | 13   | 16   | 19   | dB               | RNE     |                                |
| CD ~Rec                               | GvcCR      | 2    | 5    | 8    | dB               | CNE     |                                |
| Tape ~Line                            | GvcTL1     | 54   | 57   | 60   | dB               | TAE     | $V_{IN}=76\text{dBm}$ , 315Hz  |
| Tape ~Line                            | GvcTL2     | 41.6 | 44   | 46.4 | dB               | TAE     | $V_{IN}=-63\text{dBm}$ , 10kHz |
| Maximum output voltage                |            |      |      |      |                  |         |                                |
| Line Out                              | $V_{OML}$  | 2.5  | 4.5  | —    | dBm              | TNM     | Mic input<br>THD=1%            |
| Rec Out                               | $V_{OMR}$  | 2.0  | 4.0  | —    | dBm              | TNM     | THD=3%, ALC OFF                |
| Total harmonic distortion             |            |      |      |      |                  |         |                                |
| Mic ~Line                             | THD ML     | —    | 0.08 | 0.5  | %                | TNM     |                                |
| Radio~Line                            | THD RL     | —    | 0.02 | 0.5  | %                | RNE     |                                |
| CD ~Line                              | THD CL     | —    | 0.02 | 0.5  | %                | CNE     |                                |
| Radio~Rec                             | THD RR     | —    | 0.2  | 0.7  | %                | RNE     | ALC OFF                        |
| CD ~Rec                               | THD CR     | —    | 0.2  | 0.7  | %                | CNE     | ALC OFF                        |
| Tape ~Line                            | THD TL     | —    | 0.1  | 0.7  | %                | TAE     |                                |
| Input conversion noise voltage (Tape) | $V_{NINT}$ | —    | 0.8  | 1.6  | $\mu\text{Vrms}$ | TAE     | DIN AUDIO<br>Line Out          |
| Input conversion noise voltage (CD)   | $V_{NoCD}$ | —    | 5    | 10   | $\mu\text{Vrms}$ | CAE     | DIN AUDIO<br>Line Out          |

Preamplifiers

Low-frequency amplifiers

## ● Electrical characteristics

| Parameter                   | Symbol             | Min. | Typ. | Max. | Unit | Symbol* | Conditions   |
|-----------------------------|--------------------|------|------|------|------|---------|--|
| Rec EQ Amp f characteristic |                    |      |      |      |      |         | CD Input   |
| Nor                         | $\Delta G_{vcNor}$ | 4.6  | 7.0  | 9.4  | dB   | CNE     | Measured at 10kHz<br>(output voltage = 0dB at f = 1kHz)  |
| HS                          | $\Delta G_{vcHS}$  | 1.7  | 3.7  | 5.7  | dB   | CHE     | Measured at 10kHz<br>(output voltage = 0dB at f = 1kHz)  |
| PB EQ Amp f characteristic  | $\Delta G_{vcPB}$  | 3.1  | 5.5  | 7.9  | dB   | D * E   | * =Difference between N and H output levels at f = 10kHz. Measured at Line Out.  |
| L/R channel separation      |                    |      |      |      |      |         |  |
| Radio ~Line                 | $CS_{LRRL}$        | 55   | 66   | —    | dB   | RNE     | $V_o = 0dBm$   |
| CD ~Line                    | $CS_{LRCL}$        | 55   | 66   | —    | dB   | CNE     | $V_o = 0dBm$   |
| Tape ~Line                  | $CS_{LRTL}$        | 50   | 62   | —    | dB   | TAE     | $V_o = 0dBm$   |
| Radio ~Rec                  | $CS_{LRRL}$        | 50   | 54   | —    | dB   | RNE     | $V_o = -6dBm$  |
| CD ~Rec                     | $CS_{LRRL}$        | 50   | 54   | —    | dB   | CNE     | $V_o = -6dBm$  |
| A/B crosstalk               | $CT_{AB}$          | —    | -67  | -60  | dBm  | T * E   | With (TAE) Tape A input, and Line Out = 0dBm, switch to (TBE) and measure the Line Out level.                            |
| PB - REC crosstalk          | $CT_{RP}$          | —    | -92  | -80  | dBm  | C * E   | With (CNE) CD input, ALC off, and Rec Out = 0dBm, switch ALC on, switch to (CAE) and measure the Rec Out level (tape B). |
| Mic mute level              | MM                 | —    | -66  | -55  | dBm  | TN *    | With (TNM) Mic input, and Line Out = 0dBm, switch to (TNE) and measure the Line Out level.                               |
| ALC distortion              | $THD_{ALC}$        | —    | 0.5  | 1    | %    | TNE     | Mic input = -40dBm<br>Measured at Rec Out.   |
| ALC level                   | $V_{ALC}$          | -5.7 | -3.7 | -1.7 | dBm  | TNE     | Mic input = -30dBm<br>Measured at Rec Out.   |
| ALC balance                 | $CB_{ALC}$         | —    | 0    | 2.5  | dB   | TNE     | Mic input = -30dBm<br>Measured at Rec Out.   |
| ALC current capacity        | $I_{ALC}$          | 4.0  | 7.7  | —    | mA   | TNE     | Mic input = -30dBm<br>Average $\tau$ pin output current.   |

●Electrical characteristics

| Parameter                                     | Symbol           | Min.             | Typ.                | Max. | Unit                | Symbol* |  | Conditions      |
|---|------------------|------------------|---------------------|------|---------------------|---------|--|-----------------|
|   |                  |                  |                     |      |                     | Symbol* | Conditions   |                 |
| Mic/HS pin output voltage                     | HS               | VHS              | 1.0                 | 1.4  | —                   | V       | CH—  | Current: 300 μA |
|   | Nor              | VNor             | —                   | 0.38 | 0.43                |         | CNE  |                 |
| Mic/HS pin threshold resistance               | ECM              | RECM             | —                   | 50   | 100                 | kΩ      |  |                 |
|   | Mic              | RMic             | 30                  | 50   | —                   |         |  |                 |
| Function pin threshold voltage                | Dubbing          | V <sub>F</sub> R | 0.86V <sub>cc</sub> | —    | V <sub>cc</sub>     | V       |  |                 |
|   | Tape             | V <sub>F</sub> C | 0.57V <sub>cc</sub> | —    | 0.82V <sub>cc</sub> |         |  |                 |
|   | CD               | V <sub>F</sub> D | 0.27V <sub>cc</sub> | —    | 0.53V <sub>cc</sub> |         |  |                 |
|   | Radio            | V <sub>F</sub> T | 0.07V <sub>cc</sub> | —    | 0.23V <sub>cc</sub> |         |  |                 |
| Tape mode pin threshold voltage               | Nor Rec          | V <sub>T</sub> N | 0.86V <sub>cc</sub> | —    | V <sub>cc</sub>     | V       |  |                 |
|   | HS Rec           | V <sub>T</sub> H | 0.57V <sub>cc</sub> | —    | 0.82V <sub>cc</sub> |         |  |                 |
|   | B mechanism      | V <sub>T</sub> B | 0.31V <sub>cc</sub> | —    | 0.53V <sub>cc</sub> |         |  |                 |
|   | A mechanism      | V <sub>T</sub> A | 0.09V <sub>cc</sub> | —    | 0.27V <sub>cc</sub> |         |  |                 |
| Bias oscillator transistor saturation voltage | V <sub>SAT</sub> | —                | 0.24                | 0.35 | V                   | CNE     | Current: 10mA, 10kΩ resistor connected between V <sub>cc</sub> and pin 30. |                 |

\* Meaning of the abbreviations in the symbol column

| Pin   | Symbol | Meaning     | Applied voltage or state   |
|-------|--------|-------------|--|
| 7pin  | E      | ECM         | Open   |
|       | M      | Mic         | Connected to GND via 10kΩ  |
| 28pin | N      | Nor Rec     | Connected to V <sub>cc</sub> via 10kΩ  |
|       | H      | HS Rec      | Connected to V <sub>cc</sub> via 10kΩ and to GND via 22kΩ                              |
|       | B      | B mechanism | Connected to V <sub>cc</sub> via 6.9kΩ (22k in parallel with 10k) and to GND via 4.7kΩ |
|       | A      | A mechanism | Connected to V <sub>cc</sub> via 22kΩ and to GND via 4.7kΩ                             |
| 27pin | D      | Dubbing     | Connected to V <sub>cc</sub> via 10kΩ  |
|       | T      | Tape        | Connected to V <sub>cc</sub> via 10kΩ and to GND via 22kΩ                              |
|       | C      | CD          | Connected to V <sub>cc</sub> via 10kΩ and to GND via 6.8kΩ                             |
|       | R      | Radio       | Connected to V <sub>cc</sub> via 10kΩ and to GND via 1kΩ                               |

Preamplifiers

Low-frequency amplifiers

● Measurement circuit

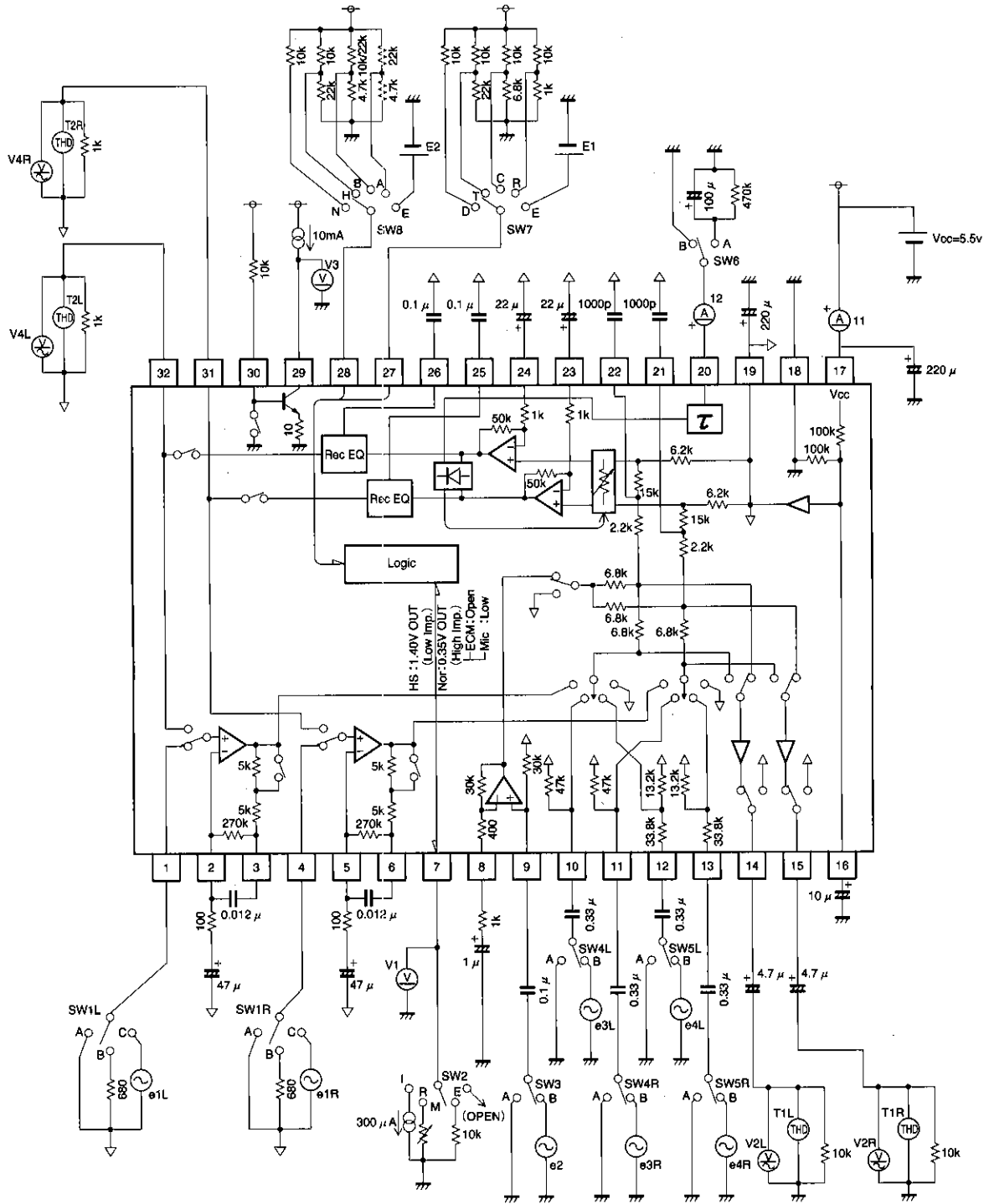

Fig. 1

●Circuit operation

(1) Control pins

The control pin inputs and the corresponding states of the various inputs and outputs are summarized in the input/output pin status table that follows.

Control pin inputs and corresponding input/output pin states

| Function | Control Pin |                                | Input/Output Condition |         |          |         |          |         |          |         |          |         | Bias OSC Tr. | HS Out | Transient mute | Set Mode       |             |
|----------|-------------|--------------------------------|------------------------|---------|----------|---------|----------|---------|----------|---------|----------|---------|--------------|--------|----------------|----------------|-------------|
|          | Tape Mode   | ECM/Mic<br>Open=ECM<br>Low=Mic | A In                   |         | B In     |         | CD In    |         | Radio In |         | Mic In   |         |              |        |                |                |             |
|          |             |                                | Line Out               | Rec Out | Line Out | Rec Out | Line Out | Rec Out | Line Out | Rec Out | Line Out | Rec Out |              |        |                |                |             |
| Dub      | Nor Rec     | ECM                            | ●                      | ●       | ×        | ×       | ×        | ×       | ×        | ×       | ×        | ×       | ×            | on     | Low            |                | Dubbing     |
|          |             | Mic                            | ●                      | ●       | ×        | ×       | ×        | ×       | ×        | ×       | ●        | ●       | on           | Low    | on             |                | Mix—Dubbing |
|          | HS—R        | ECM                            | ●HS                    | ●HS     | ×        | ×       | ×        | ×       | ×        | ×       | ×        | ×       | ×            | on     | High           | on             | HS—Dubbing  |
|          |             | B PB                           | ECM                    | ×       | open     | ●       | open     | ×       | open     | ×       | open     | ×       | open         | off    | Low            | on             | B—Play      |
|          | A PB        | ECM                            | ●                      | open    | ×        | open    | ×        | open    | ×        | open    | ×        | open    | off          | Low    | on             | A—Play         |             |
|          |             | Mic                            | ●                      | open    | ×        | open    | ×        | open    | ×        | open    | ●        | open    | off          | Low    | on             | A—Mix—Play     |             |
| Tape     | Nor Rec     | ECM                            | ×                      | ×       | ×        | ×       | ×        | ×       | ×        | ×       | ×        | ●       | on           | Low    | on             | ECM—Rec        |             |
|          |             | Mic                            | ×                      | ×       | ×        | ×       | ×        | ×       | ×        | ×       | ●        | ●       | on           | Low    | on             | Mic—Rec        |             |
|          | HS Rec      | ECM                            | ×                      | ×       | ×        | ×       | ×        | ×       | ×        | ×       | ×        | ●       | on           | Low    | on             | ECM—Rec        |             |
|          |             | Mic                            | ×                      | ×       | ×        | ×       | ×        | ×       | ×        | ×       | ●        | ●       | on           | Low    | on             | Mic—Rec        |             |
|          | B PB        | ECM                            | ×                      | open    | ●        | open    | ×        | open    | ×        | open    | ×        | open    | off          | Low    | on             | B—Play         |             |
|          |             | Mic                            | ×                      | open    | ●        | open    | ×        | open    | ×        | open    | ●        | open    | off          | Low    | on             | B—Mix—Play     |             |
| A PB     | ECM         | ●                              | open                   | ×       | open     | ×       | open     | ×       | open     | ×       | open     | off     | Low          | on     | A—Play         |                |             |
|          | Mic         | ●                              | open                   | ×       | open     | ×       | open     | ×       | open     | ●       | open     | off     | Low          | on     | A—Mix—Play     |                |             |
| CD       | Nor Rec     | ECM                            | ×                      | ×       | ×        | ×       | ●        | ●       | ×        | ×       | ×        | ×       | on           | Low    | *              | CD—Dubbing     |             |
|          |             | Mic                            | ×                      | ×       | ×        | ×       | ●        | ●       | ×        | ×       | ●        | ●       | on           | Low    | *              | CD—Mix—Dubbing |             |
|          | HS—R        | ECM                            | ×                      | ×       | ×        | ×       | ●HS      | ●HS     | ×        | ×       | ×        | ×       | on           | High   | *              | CD—HS—Dubbing  |             |
|          |             | B PB                           | ECM                    | ×       | open     | ×       | open     | ●       | open     | ×       | open     | ×       | open         | off    | Low            | *              | CD—Play     |
|          | A PB        | ECM                            | ×                      | open    | ×        | open    | ●        | open    | ×        | open    | ×        | open    | off          | Low    | *              | CD—Play        |             |
|          |             | Mic                            | ×                      | open    | ×        | open    | ●        | open    | ×        | open    | ●        | open    | off          | Low    | *              | CD—Mix—Play    |             |
| Radio    | Nor Rec     | ECM                            | ×                      | ×       | ×        | ×       | ×        | ×       | ●        | ●       | ×        | ×       | on           | Low    | *              | Rad—Rec        |             |
|          |             | Mic                            | ×                      | ×       | ×        | ×       | ×        | ×       | ●        | ●       | ●        | ●       | on           | Low    | *              | Rad—Mix—Rec    |             |
|          | HS Rec      | ECM                            | ×                      | ×       | ×        | ×       | ×        | ×       | ●        | ●       | ×        | ×       | on           | Low    | *              | Rad—Rec        |             |
|          |             | Mic                            | ×                      | ×       | ×        | ×       | ×        | ×       | ●        | ●       | ●        | ●       | on           | Low    | *              | Rad—Mix—Rec    |             |
|          | B PB        | ECM                            | ×                      | open    | ×        | open    | ×        | open    | ●        | open    | ×        | open    | off          | Low    | *              | Rad—Play       |             |
|          |             | Mic                            | ×                      | open    | ×        | open    | ×        | open    | ●        | open    | ●        | open    | off          | Low    | *              | Rad—Mix—Play   |             |
| A PB     | ECM         | ×                              | open                   | ×       | open     | ×       | open     | ●       | open     | ×       | open     | off     | Low          | *      | Rad—Play       |                |             |
|          | Mic         | ×                              | open                   | ×       | open     | ×       | open     | ●       | open     | ●       | open     | off     | Low          | *      | Rad—Mix—Play   |                |             |

\* Only the A-PLAY Y/B-PLAY switch goes off.

● :Corresponding signal is output.

●HS:The corresponding signal has the high-speed mode equalizer characteristic applied and is output.

× :Corresponding signal is output.

open:in the open (high impedance) state, no signal is output from output pin.

Preamplifiers

Low-frequency amplifiers



●Application example 1

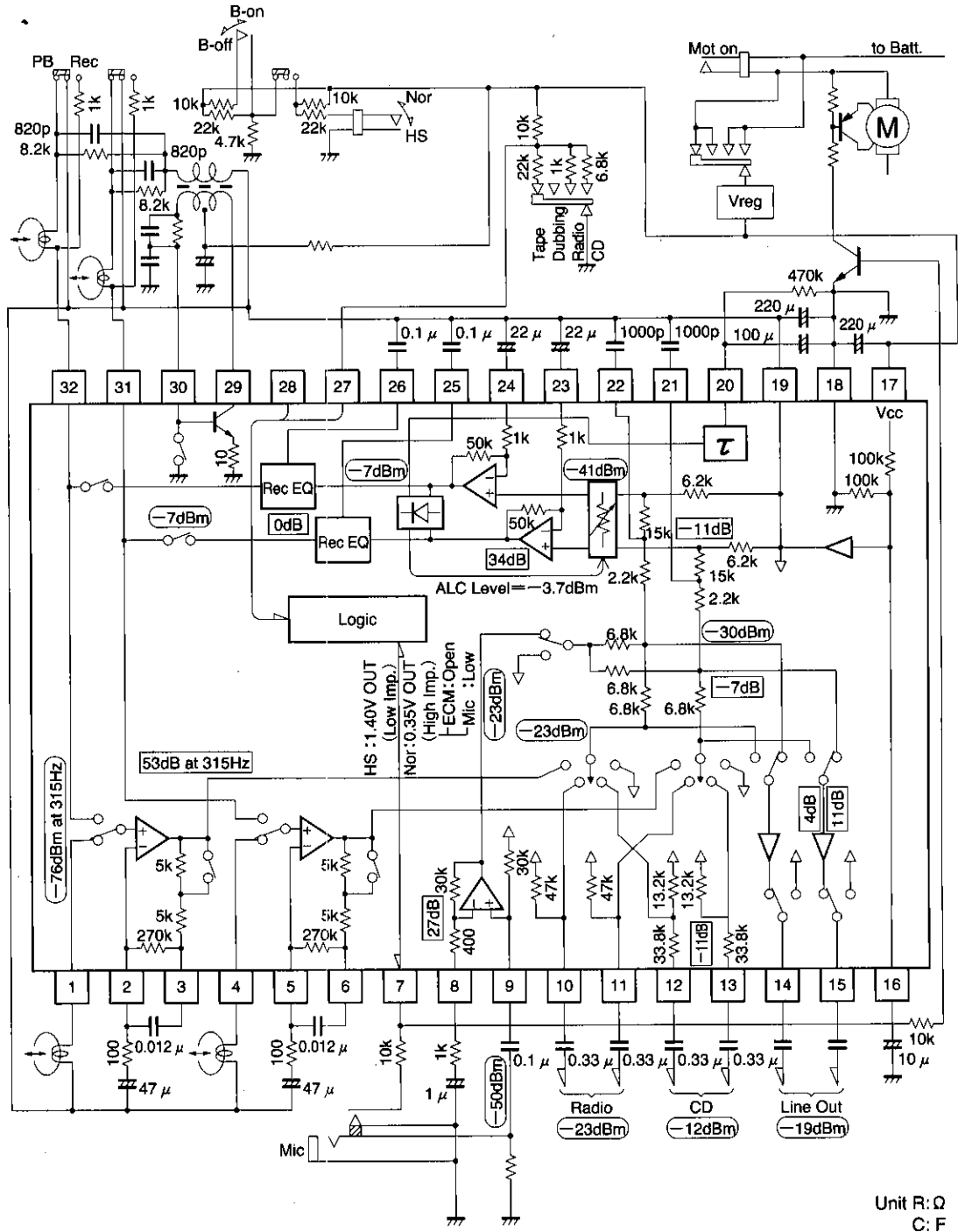

Fig. 2

Unit R: Ω  
C: F

● Application example 2

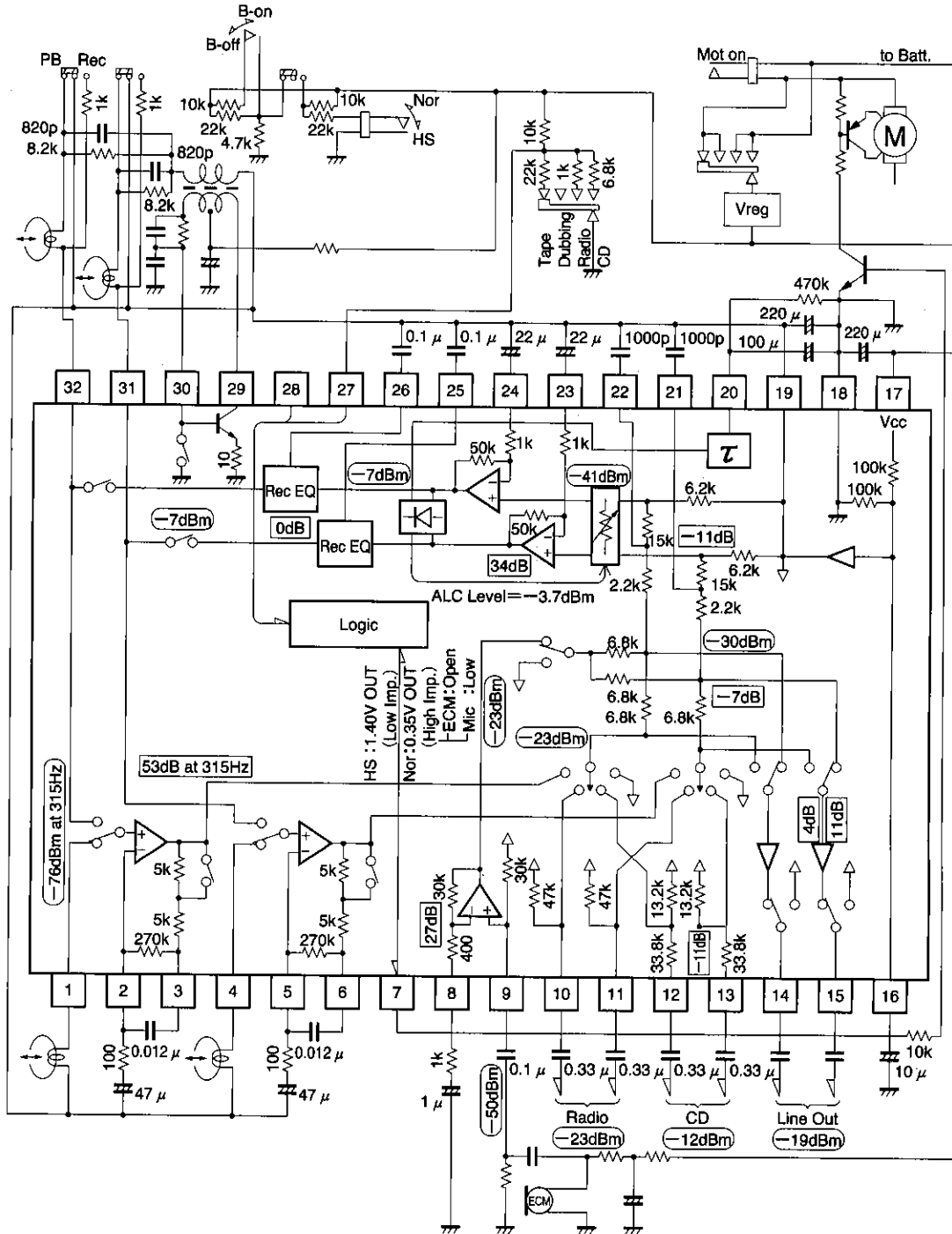

Fig. 3

Preamplifiers

Low-frequency amplifiers

● Operation notes

(1) Amplifier oscillation

As the BA3426S incorporates dual-cassette dubbing functions on a single IC, it has extremely high input/output gain. In particular, in normal-speed mode, the gain at around the recording equalizer peaking characteristic frequency is about 70dB. The phases of the input and output are reversed to reduce the chance of oscillation due to influence of the PCB pattern, but due consideration must be given to the PCB pattern design to prevent oscillation. In particular, the PCB tracks to the Tape A pins (pins 1 and 4) and Tape B pins (pins 31 and 32) should be sufficiently far apart that there is no coupling capacitance between them, or they should be shielded by having a GND or bias track between them.

(2) Strong RF signals

To prevent signal mixing due to strong electric fields, connect a capacitor (of a few hundred pF) to each input pin. These must be connected close to the pins of the IC to have any effect. Design the PCB track layout so that the capacitors can be connected as close to the base of the pins as possible.

● Electrical characteristics curves

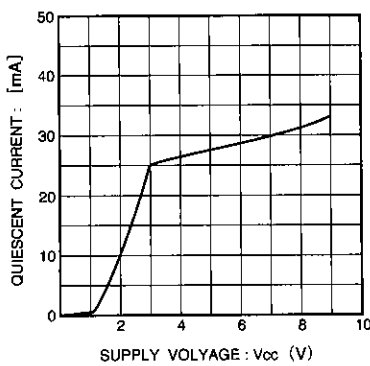

Fig. 4 Quiescent current vs. supply voltage

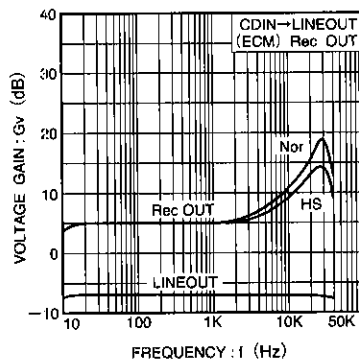

Fig. 5 Voltage gain vs. frequency

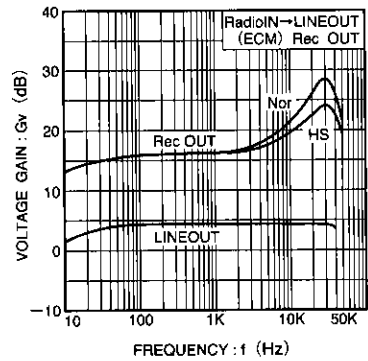

Fig. 6 Voltage gain vs. frequency

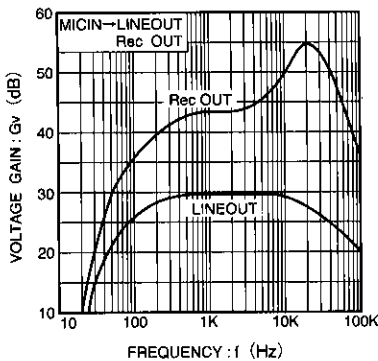

Fig. 7 Voltage gain vs. frequency

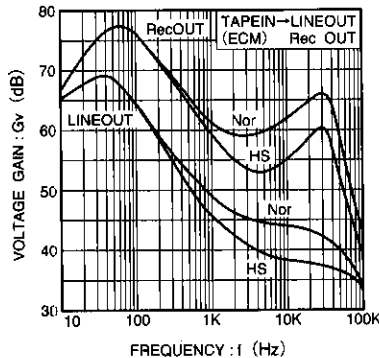
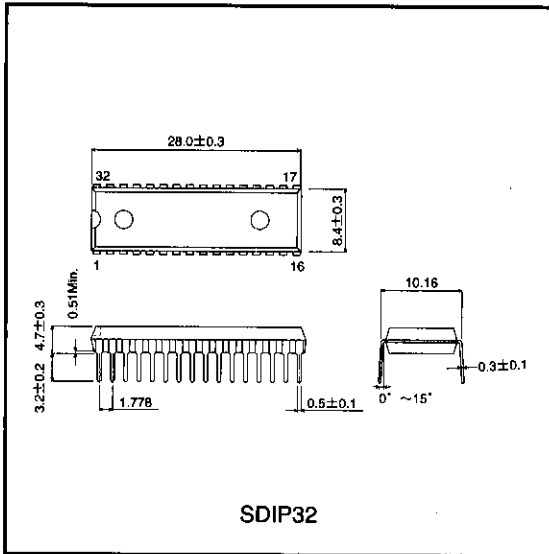

Fig. 8 Voltage gain vs. frequency

● External dimensions (Unit: mm)



Preamplifiers

Low-frequency amplifiers

## Notes

- The contents described in this catalogue are correct as of March 1997.
- No unauthorized transmission or reproduction of this book, either in whole or in part, is permitted.
- The contents of this book are subject to change without notice. Always verify before use that the contents are the latest specifications. If, by any chance, a defect should arise in the equipment as a result of use without verification of the specifications, ROHM CO., LTD., can bear no responsibility whatsoever.
- Application circuit diagrams and circuit constants contained in this data book are shown as examples of standard use and operation. When designing for mass production, please pay careful attention to peripheral conditions.
- Any and all data, including, but not limited to application circuit diagrams, information, and various data, described in this catalogue are intended only as illustrations of such devices and not as the specifications for such devices. ROHM CO., LTD., disclaims any warranty that any use of such device shall be free from infringement of any third party's intellectual property rights or other proprietary rights, and further, assumes absolutely no liability in the event of any such infringement, or arising from or connected with or related to the use of such devices.
- Upon the sale of any such devices; other than for the buyer's right to use such devices itself, resell or otherwise dispose of the same; no express or implied right or license to practice or commercially exploit any intellectual property rights or other proprietary rights owned or controlled by ROHM CO., LTD., is granted to any such buyer.
- The products in this manual are manufactured with silicon as the main material.
- The products in this manual are not of radiation resistant design.

The products listed in this catalogue are designed to be used with ordinary electronic equipment or devices (such as audio-visual equipment, office-automation equipment, communications devices, electrical appliances, and electronic toys). Should you intend to use these products with equipment or devices which require an extremely high level of reliability and the malfunction of which would directly endanger human life (such as medical instruments, transportation equipment, aerospace machinery, nuclear-reactor controllers, fuel controllers, or other safety devices) please be sure to consult with our sales representatives in advance.

- Notes when exporting
  - It is essential to obtain export permission when exporting any of the above products when it falls under the category of strategic material (or labor) as determined by foreign exchange or foreign trade control laws.
  - Please be sure to consult with our sales representatives to ascertain whether any product is classified as a strategic material.