

74LVT652

3.3V ABT Octal Transceiver/Register with TRI-STATE® Outputs

General Description

The LVT652 consists of bus transceiver circuits with D-type flip-flops, and control circuitry arranged for multiplexed transmission of data directly from the input bus or from the internal registers. Data on the A or B bus will be clocked into the registers as the appropriate clock pin goes to HIGH logic level. Output Enable pins (OEAB, \overline{OEBA}) are provided to control the transceiver function.

These bus/octal buffers and line drivers is/are designed for low-voltage (3.3V) V_{CC} applications, but with the capability to provide a TTL interface to a 5V environment. The LVT652 is fabricated with an advanced BiCMOS technology to achieve high speed operation similar to 5V ABT while maintaining a low power dissipation.

Features

- Input and output interface capability to systems at 5V V_{CC}
- Bus-Hold data inputs eliminate the need for external pull-up resistors to hold unused inputs
- Live insertion/extraction permitted
- Power Up/Down high impedance provides glitch-free bus loading
- Outputs source/sink -32 mA/ $+64$ mA
- Available in SOIC JEDEC and TSSOP
- Functionally compatible with the 74 series 652
- Latch-up performance exceeds 500 mA

Ordering Code: See Section 11

Logic Symbols

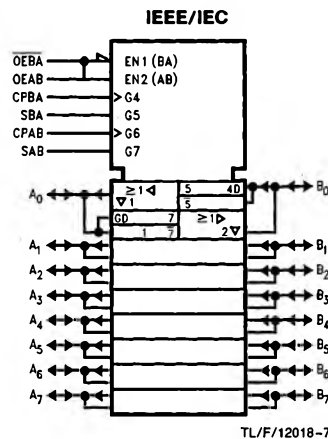
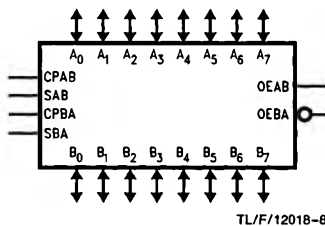

Connection Diagram

Pin Assignment for SOIC and TSSOP

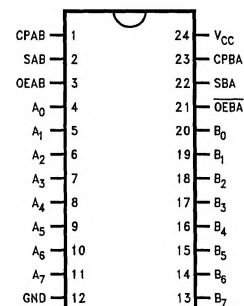

Pin Names	Description
A ₀ -A ₇	Data Register A Inputs/ TRI-STATE Outputs
B ₀ -B ₇	Data Register B Inputs/ TRI-STATE Outputs
CPAB, CPBA	Clock Pulse Inputs
SAB, SBA	Select Inputs
OEAB, \overline{OEBA}	Output Enable Inputs

	SOIC JEDEC	TSSOP JEDEC
Order Number	74LVT652WM 74LVT652WMX	74LVT652MTCX
See NS Package Number	M24B	MTC24

Logic Diagram

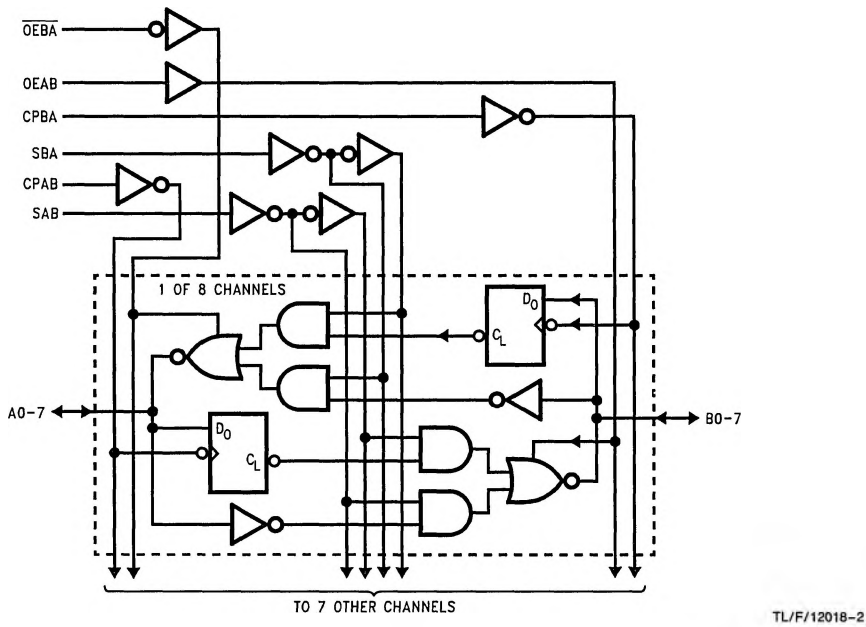

Please note that this diagram is provided only for the understanding of logic operations and should not be used to estimate propagation delays.

Functional Description

In the transceiver mode, data present at the HIGH impedance port may be stored in either the A or B register or both. The select (SAB, SBA) controls can multiplex stored and real-time.

The examples in *Figure 1* demonstrate the four fundamental bus-management functions that can be performed with the LVT652.

Data on the A or B data bus, or both can be stored in the internal D flip-flop by LOW to HIGH transitions at the appro-

appropriate Clock Inputs (CPAB, CPBA) regardless of the Select or Output Enable Inputs. When SAB and SBA are in the real time transfer mode, it is also possible to store data without using the internal D flip-flops by simultaneously enabling OEAB and OEBA. In this configuration each Output reinforces its input. Thus when all other data sources to the two sets of bus lines are in a HIGH impedance state, each set of bus lines will remain at its last state.

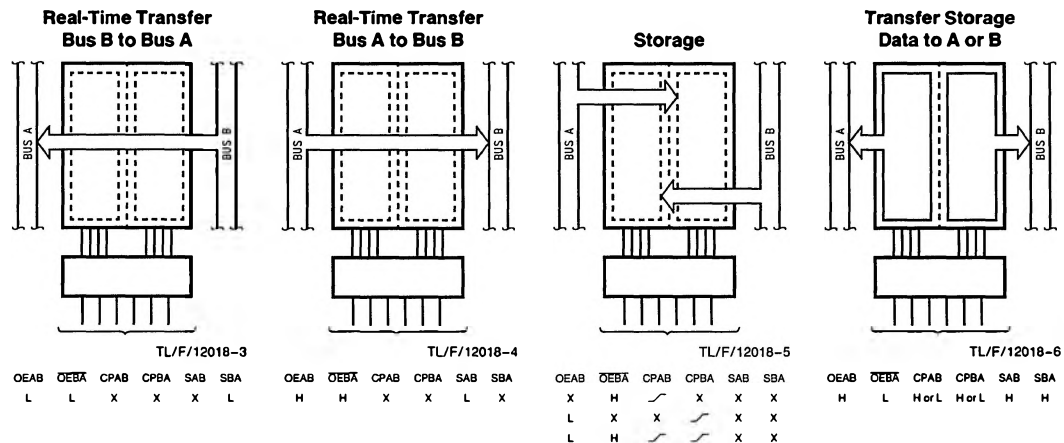











FIGURE 1

Truth Table (Note)

Inputs						Inputs/Outputs		Operating Mode
OEAB	OEBA	CPAB	CPBA	SAB	SBA	A ₀ thru A ₇	B ₀ thru B ₇	
L	H	H or L	H or L	X	X	Input	Input	Isolation
L	H			X	X			Store A and B Data
X	H		H or L	X	X	Input	Not Specified	Store A, Hold B
H	H			X	X	Input	Output	Store A in Both Registers
L	X	H or L		X	X	Not Specified	Input	Hold A, Store B
L	L			X	X	Output	Input	Store B in Both Registers
L	L	X	X	X	L	Output	Input	Real-Time B Data to A Bus
L	L	X	H or L	X	H			Store B Data to A Bus
H	H	X	X	L	X	Input	Output	Real-Time A Data to B Bus
H	H	H or L	X	H	X			Stored A Data to B Bus
H	L	H or L	H or L	H	H	Output	Output	Stored A Data to B Bus and Stored B Data to A Bus

H = HIGH Voltage Level L = LOW Voltage Level X = Immaterial  = LOW to HIGH Clock Transition

Note: The data output functions may be enabled or disabled by various signals at OEAB or OEBA inputs. Data input functions are always enabled, i.e., data at the bus pins will be stored on every LOW to HIGH transition on the clock inputs.