

### DESCRIPTION

The AKG D-900E is a professional, ultradirectional microphone designed to provide effective dialog pickup at medium to long working distances — those beyond the capabilities of standard cardioid microphones. Because of its combination of high performance, operating features, versatility and modern price, the D-900E has won wide acceptance in a variety of live-television and videotape applications (ranging from remote news-gathering and sports coverage to the most elaborate dramatic and variety shows); many feature, documentary, and ciné-ma-vérité film productions; and a number of major theatrical presentations.

At up to three or four times the "normal" working distance of a cardioid, the D-900E is still capable of yielding required output level, high-quality speech reproduction, and excellent rejection of ambient noise or acoustic feedback. These qualities make it ideal for use under the difficult acoustic conditions often imposed in video and film when the dialog microphone must be kept out of camera range during medium and long shots. Similarly, they render the D-900E useful in theatrical sound-reinforcement applications in which the microphone must be hidden from audience view near the lip of the stage or — where acoustics permit — in the fliers or rigging above the stage.

The D-900E achieves its relatively high output and extremely tight directional pattern by employing a sensitive pressure-gradient dynamic transducer, a front- and side-ported housing, and an acoustic-interference tube over 19 inches in length. Through careful integration of these three design elements, the D-900E maintains useable directionality throughout its *entire* frequency range — including the critical lower frequencies. (Its outstanding polar response at 1000 Hz is suggestive of the microphone's overall directionality: almost 10 dB rejection at just 60 degrees off axis; increasing rapidly to 15 dB at 75 degrees off axis; and ranging between 20 and 30 dB from 90 degrees through 180 degrees off axis.)

On-axis performance is characterized by exceptionally smooth frequency response free of bumps, dips, or other spurious irregularities. Low-frequency response is gradually rolled off below 300 Hz to impart clarity and crispness to speech. This is important at the longer working distances at which a shotgun microphone is often used.

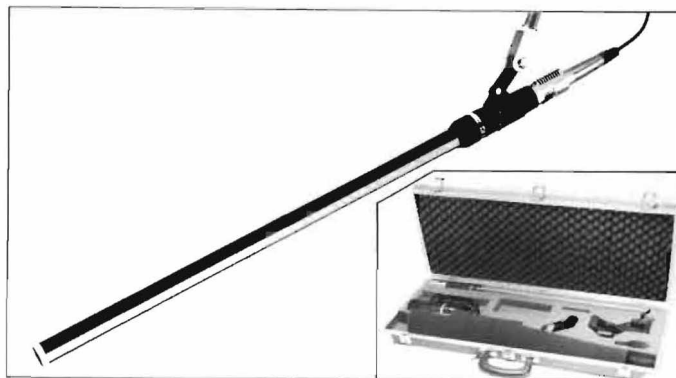

A built-in three-position bass-rolloff switch and inductive-resistive network provide an additional 7 dB or 20 dB attenuation at 50 Hz, as required. This feature is especially useful when the microphone must be used in acoustically unfavorable environments with excessive low-frequency ambient noise, reverberation, feedback, wind rumble, or boom vibration.

Capable of withstanding an extraordinarily wide range of temperatures and moderately high humidity, the D-900E is a slim, relatively lightweight microphone that may be hand-held on a pistol grip, suspended from a fishpole or boom, or mounted on a stand or clamp. All these factors combine to make the versatile D-900E equally adaptable for use indoors or outdoors (with its recommended windscreens) — whether on location, in the studio, or on stage.

The D-900E is a low-impedance balanced-output unit fitted with a standard 3-pin male XLR-type connector. The microphone is supplied complete with an SA-16/1 stand adapter and a zippered vinyl carrying case with protective foam packing. Several optional accessories — listed in the Technical Data section — are available.

The D-900E is also available as part of a complete system capable of handling virtually any shotgun assignment. Included are the microphone, SA-16/1 stand adapter, SA-70/9 pistol-grip and boom-suspension adapter, H-7 pistol grip, H-70 boom-suspension shock mount, W-19 windscreen and MCH-20 6.1 m (≈20 ft) cable assembly — all housed in a CC-9 fitted, foamed carrying case.

### FREQUENCY AND POLAR RESPONSE

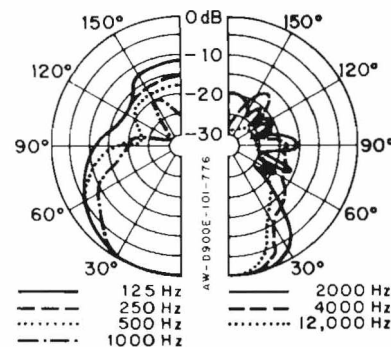
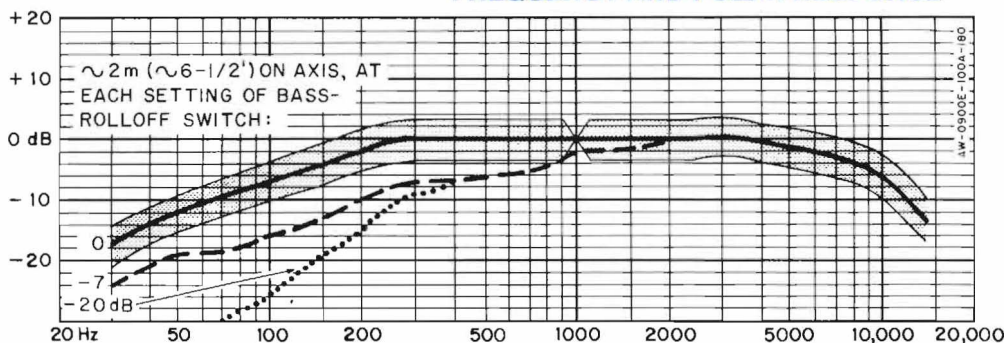

## TECHNICAL DATA

**Transducer Type:** Dynamic  
**Directional Characteristic:** Shotgun-hypercardioid  
**Frequency Range:** 60-12,000 Hz (bass-rolloff switch at "0")  
**Nominal Impedance:** 200 ohms  
**Recommended Load Impedance:**  $\geq 500$  ohms  
**Sensitivity at 1 kHz:**  
   Open circuit: 3.0 mV/Pa; -50.5 dBV\*  
   Maximum power level: -49.5 dBm (re: 1mW/10 dynes/cm<sup>2</sup>)  
   EIA G<sub>m</sub>: -142 dBm  
   Tolerance: +1, -2 dB  
**Sound Pressure Level for 1% THD:**  
   40 Hz, 1000 Hz, 5000 Hz: 128 dB  
**Hum Sensitivity:** -125 dBm (1 mG field)  
**Temperature Range:** -25°C ( $\approx$  -13°F) to +70°C ( $\approx$  +158°F)  
**Maximum Relative Humidity:** 90%  
**Case Material:** Brass, matte-black lacquered/nickel plated

**Dimensions:** See Dimensions figure below  
**Schematic:** See Schematic figure below  
**Net Weight:** 510 g ( $\approx$  18 oz)  
**Included Accessories:**  
   SA-16/1 metal-base stand adapter with 5/8-in. -27 thread  
   Zippered vinyl carrying case with protective foam packing  
**Optional Accessories:**  
   SA-18/9 clamp-type stand adapter with 5/8-in. -27 thread  
   SA-70/9 pistol-grip & boom-suspension adptr for H-7, H-70  
   H-7 rubber pistol-grip handle } use either with  
   H-70 boom-suspension shock mount } SA-70/9 above  
   W-9A foam windscreen (for rear of microphone)  
   W-19 foam windscreen (for interference tube)  
   KM-series floor and boom stands, stand accessories  
   MCH-series heavy-duty microphone-cable assemblies  
   CC-9 carrying case for microphone w/all accys except stand

\*1 Pa (Pascal) = 10  $\mu$ b = 10 dynes/cm<sup>2</sup>  $\approx$  94 dB SPL

## ARCHITECTS' AND ENGINEERS' SPECIFICATIONS

The microphone shall be a shotgun type, consisting of a dynamic pressure-gradient transducer in a front- and side-ported housing having a long acoustic-interference tube fitted over its front port. It shall employ an inductive-resistive network and a three-position bass-rolloff switch to shape frequency-response characteristics at 2 m ( $\approx$  6-1/2 ft) on axis as follows: (1) the "0" position of the switch shall produce an unmodified frequency range of 60-12,000 Hz with 12 dB rolloff attenuation at 50 Hz; (2) the "-7" position of the switch shall introduce an additional 7 dB rolloff at 50 Hz for a total attenuation of 19 dB at that frequency; (3) the "-20 dB" position of the switch shall introduce an additional 20 dB rolloff at 50 Hz for a total attenuation of 32 dB at that frequency. The microphone shall have a shotgun-hypercardioid directional pattern. Typical front-to-side and front-to-rear discrimination at 1000 Hz shall be 20 dB at a sound-incidence angle of 90 degrees, 30 dB at a sound-incidence angle of 120 degrees, 20 dB at a sound-incidence angle of 150 degrees, and 25 dB at a sound-incidence angle of 180 degrees; and an effective hypercardioid pattern shall be maintained at 500 Hz and below.

level of 50 Pa (128 dB SPL) at 1000 Hz with distortion not exceeding 1%. The EIA sensitivity rating (G<sub>m</sub>) shall be -142 dBm.

A wire-mesh screen, commensurate with the acoustical properties of the unit, shall protect the microphone system from metal particles and dust. The diaphragm material shall be nonmetallic MAKROFOLTM. The microphone shall be capable of operating over a temperature range of -25°C ( $\approx$  -13°F) to +70°C ( $\approx$  +158°F), and at a maximum relative humidity of 90%.

The microphone shall incorporate a 3-pin male audio connector designed to mate with Cannon XLR, Neutrik 3FC, Switchcraft A3F, or equivalent connectors. An AKG model SA-16/1 swivel stand adapter with standard 5/8-in. -27 thread, and a zippered vinyl carrying case with protective foam packing shall also be provided. The finish of the microphone shall be matte black and matte nickel, and shall not create specular light reflections.

The microphone shall have a nominal impedance of 200 ohms. The output level shall be -49.5 dBm (re: 1 mW/10 dynes/cm<sup>2</sup>), and the microphone shall be capable of handling a maximum sound-pressure

level of 50 Pa (128 dB SPL) at 1000 Hz with distortion not exceeding 1%. The EIA sensitivity rating (G<sub>m</sub>) shall be -142 dBm.

### DIMENSIONS

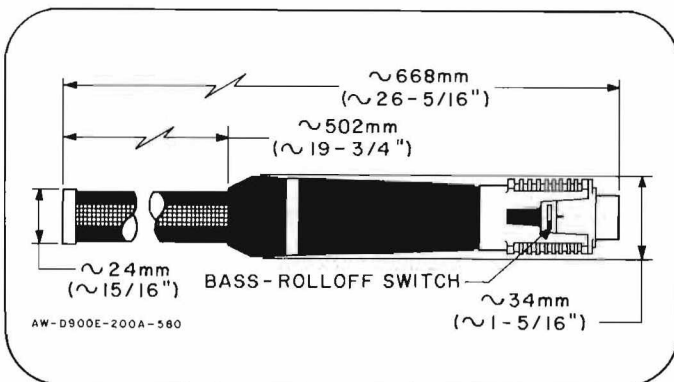

### SCHEMATIC

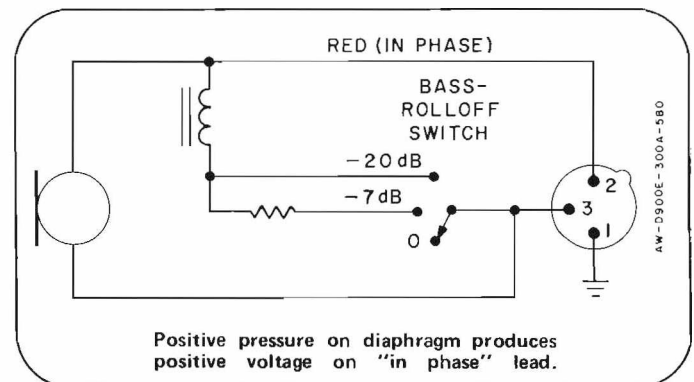

## AKG ACOUSTICS, INC.

A NORTH AMERICAN PHILIPS COMPANY

77 Selleck Street, Stamford, CT 06902 • (203) 348-2121

©AKG Acoustics, Inc. 1982

Printed in U.S.A.

®AKG Akustische und Kino-Geräte GmbH, Austria

Product design and prices are subject to change without notice.